



LG

Life's Good

North/Latin America
Europe/Africa
Asia/Oceania

Internal Use Only

<http://aic.lgservice.com>
<http://eic.lgservice.com>
<http://biz.lgservice.com>

LED LCD TV

SERVICE MANUAL

CHASSIS : LD23E

MODEL : 55LM860V/W 55LM860V/W-ZB

CAUTION

BEFORE SERVICING THE CHASSIS,
READ THE SAFETY PRECAUTIONS IN THIS MANUAL.



CONTENTS

CONTENTS	2
SAFETY PRECAUTIONS	3
SERVICING PRECAUTIONS.....	4
SPECIFICATION	6
ADJUSTMENT INSTRUCTION	12
EXPLODED VIEW	21
SCHEMATIC CIRCUIT DIAGRAM	

SAFETY PRECAUTIONS

IMPORTANT SAFETY NOTICE

Many electrical and mechanical parts in this chassis have special safety-related characteristics. These parts are identified by \triangle in the Schematic Diagram and Exploded View.

It is essential that these special safety parts should be replaced with the same components as recommended in this manual to prevent Shock, Fire, or other Hazards.

Do not modify the original design without permission of manufacturer.

General Guidance

An **isolation Transformer should always be used** during the servicing of a receiver whose chassis is not isolated from the AC power line. Use a transformer of adequate power rating as this protects the technician from accidents resulting in personal injury from electrical shocks.

It will also protect the receiver and its components from being damaged by accidental shorts of the circuitry that may be inadvertently introduced during the service operation.

If any fuse (or Fusible Resistor) in this TV receiver is blown, replace it with the specified.

When replacing a high wattage resistor (Oxide Metal Film Resistor, over 1 W), keep the resistor 10 mm away from PCB.

Keep wires away from high voltage or high temperature parts.

Before returning the receiver to the customer,

always perform an **AC leakage current check** on the exposed metallic parts of the cabinet, such as antennas, terminals, etc., to be sure the set is safe to operate without damage of electrical shock.

Leakage Current Cold Check(Antenna Cold Check)

With the instrument AC plug removed from AC source, connect an electrical jumper across the two AC plug prongs. Place the AC switch in the on position, connect one lead of ohm-meter to the AC plug prongs tied together and touch other ohm-meter lead in turn to each exposed metallic parts such as antenna terminals, phone jacks, etc.

If the exposed metallic part has a return path to the chassis, the measured resistance should be between 1 M Ω and 5.2 M Ω .

When the exposed metal has no return path to the chassis the reading must be infinite.

An other abnormality exists that must be corrected before the receiver is returned to the customer.

Leakage Current Hot Check (See below Figure)

Plug the AC cord directly into the AC outlet.

Do not use a line Isolation Transformer during this check.

Connect 1.5 K / 10 watt resistor in parallel with a 0.15 uF capacitor between a known good earth ground (Water Pipe, Conduit, etc.) and the exposed metallic parts.

Measure the AC voltage across the resistor using AC voltmeter with 1000 ohms/volt or more sensitivity.

Reverse plug the AC cord into the AC outlet and repeat AC voltage measurements for each exposed metallic part. Any voltage measured must not exceed 0.75 volt RMS which corresponds to 0.5 mA.

In case any measurement is out of the limits specified, there is possibility of shock hazard and the set must be checked and repaired before it is returned to the customer.

Leakage Current Hot Check circuit

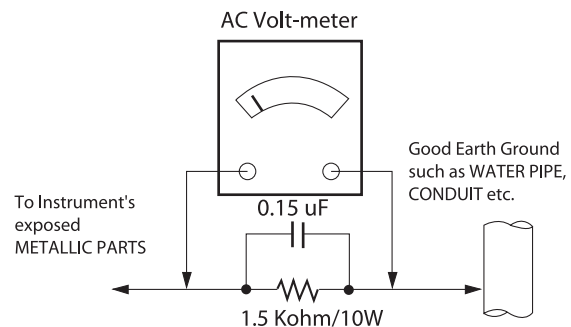

When 25A is impressed between Earth and 2nd Ground for 1 second, Resistance must be less than 0.1 Ω

*Base on Adjustment standard

SERVICING PRECAUTIONS

CAUTION: Before servicing receivers covered by this service manual and its supplements and addenda, read and follow the **SAFETY PRECAUTIONS** on page 3 of this publication.
NOTE: If unforeseen circumstances create conflict between the following servicing precautions and any of the safety precautions on page 3 of this publication, always follow the safety precautions. Remember: Safety First.

General Servicing Precautions

1. Always unplug the receiver AC power cord from the AC power source before;
 - a. Removing or reinstalling any component, circuit board module or any other receiver assembly.
 - b. Disconnecting or reconnecting any receiver electrical plug or other electrical connection.
 - c. Connecting a test substitute in parallel with an electrolytic capacitor in the receiver.
CAUTION: A wrong part substitution or incorrect polarity installation of electrolytic capacitors may result in an explosion hazard.
2. Test high voltage only by measuring it with an appropriate high voltage meter or other voltage measuring device (DVM, FETVOM, etc) equipped with a suitable high voltage probe. Do not test high voltage by "drawing an arc".
3. Do not spray chemicals on or near this receiver or any of its assemblies.
4. Unless specified otherwise in this service manual, clean electrical contacts only by applying the following mixture to the contacts with a pipe cleaner, cotton-tipped stick or comparable non-abrasive applicator; 10 % (by volume) Acetone and 90 % (by volume) isopropyl alcohol (90 % - 99 % strength)
CAUTION: This is a flammable mixture.
Unless specified otherwise in this service manual, lubrication of contacts is not required.
5. Do not defeat any plug/socket B+ voltage interlocks with which receivers covered by this service manual might be equipped.
6. Do not apply AC power to this instrument and/or any of its electrical assemblies unless all solid-state device heat sinks are correctly installed.
7. Always connect the test receiver ground lead to the receiver chassis ground before connecting the test receiver positive lead.
Always remove the test receiver ground lead last.
8. Use with this receiver only the test fixtures specified in this service manual.
CAUTION: Do not connect the test fixture ground strap to any heat sink in this receiver.

Electrostatically Sensitive (ES) Devices

Some semiconductor (solid-state) devices can be damaged easily by static electricity. Such components commonly are called Electrostatically Sensitive (ES) Devices. Examples of typical ES devices are integrated circuits and some field-effect transistors and semiconductor "chip" components. The following techniques should be used to help reduce the incidence of component damage caused by static by static electricity.

1. Immediately before handling any semiconductor component or semiconductor-equipped assembly, drain off any electrostatic charge on your body by touching a known earth ground. Alternatively, obtain and wear a commercially available discharging wrist strap device, which should be removed to prevent potential shock reasons prior to applying power to the unit under test.

2. After removing an electrical assembly equipped with ES devices, place the assembly on a conductive surface such as aluminum foil, to prevent electrostatic charge buildup or exposure of the assembly.
3. Use only a grounded-tip soldering iron to solder or unsolder ES devices.
4. Use only an anti-static type solder removal device. Some solder removal devices not classified as "anti-static" can generate electrical charges sufficient to damage ES devices.
5. Do not use freon-propelled chemicals. These can generate electrical charges sufficient to damage ES devices.
6. Do not remove a replacement ES device from its protective package until immediately before you are ready to install it. (Most replacement ES devices are packaged with leads electrically shorted together by conductive foam, aluminum foil or comparable conductive material).
7. Immediately before removing the protective material from the leads of a replacement ES device, touch the protective material to the chassis or circuit assembly into which the device will be installed.
CAUTION: Be sure no power is applied to the chassis or circuit, and observe all other safety precautions.
8. Minimize bodily motions when handling unpackaged replacement ES devices. (Otherwise harmless motion such as the brushing together of your clothes fabric or the lifting of your foot from a carpeted floor can generate static electricity sufficient to damage an ES device.)

General Soldering Guidelines

1. Use a grounded-tip, low-wattage soldering iron and appropriate tip size and shape that will maintain tip temperature within the range or 500 °F to 600 °F.
2. Use an appropriate gauge of RMA resin-core solder composed of 60 parts tin/40 parts lead.
3. Keep the soldering iron tip clean and well tinned.
4. Thoroughly clean the surfaces to be soldered. Use a small wire-bristle (0.5 inch, or 1.25 cm) brush with a metal handle. Do not use freon-propelled spray-on cleaners.
5. Use the following unsoldering technique
 - a. Allow the soldering iron tip to reach normal temperature. (500 °F to 600 °F)
 - b. Heat the component lead until the solder melts.
 - c. Quickly draw the melted solder with an anti-static, suction-type solder removal device or with solder braid.
CAUTION: Work quickly to avoid overheating the circuit board printed foil.
6. Use the following soldering technique.
 - a. Allow the soldering iron tip to reach a normal temperature (500 °F to 600 °F)
 - b. First, hold the soldering iron tip and solder the strand against the component lead until the solder melts.
 - c. Quickly move the soldering iron tip to the junction of the component lead and the printed circuit foil, and hold it there only until the solder flows onto and around both the component lead and the foil.
CAUTION: Work quickly to avoid overheating the circuit board printed foil.
 - d. Closely inspect the solder area and remove any excess or splashed solder with a small wire-bristle brush.

IC Remove/Replacement

Some chassis circuit boards have slotted holes (oblong) through which the IC leads are inserted and then bent flat against the circuit foil. When holes are the slotted type, the following technique should be used to remove and replace the IC. When working with boards using the familiar round hole, use the standard technique as outlined in paragraphs 5 and 6 above.

Removal

1. Desolder and straighten each IC lead in one operation by gently prying up on the lead with the soldering iron tip as the solder melts.
2. Draw away the melted solder with an anti-static suction-type solder removal device (or with solder braid) before removing the IC.

Replacement

1. Carefully insert the replacement IC in the circuit board.
2. Carefully bend each IC lead against the circuit foil pad and solder it.
3. Clean the soldered areas with a small wire-bristle brush. (It is not necessary to reapply acrylic coating to the areas).

"Small-Signal" Discrete Transistor Removal/Replacement

1. Remove the defective transistor by clipping its leads as close as possible to the component body.
2. Bend into a "U" shape the end of each of three leads remaining on the circuit board.
3. Bend into a "U" shape the replacement transistor leads.
4. Connect the replacement transistor leads to the corresponding leads extending from the circuit board and crimp the "U" with long nose pliers to insure metal to metal contact then solder each connection.

Power Output, Transistor Device

Removal/Replacement

1. Heat and remove all solder from around the transistor leads.
2. Remove the heat sink mounting screw (if so equipped).
3. Carefully remove the transistor from the heat sink of the circuit board.
4. Insert new transistor in the circuit board.
5. Solder each transistor lead, and clip off excess lead.
6. Replace heat sink.

Diode Removal/Replacement

1. Remove defective diode by clipping its leads as close as possible to diode body.
2. Bend the two remaining leads perpendicular y to the circuit board.
3. Observing diode polarity, wrap each lead of the new diode around the corresponding lead on the circuit board.
4. Securely crimp each connection and solder it.
5. Inspect (on the circuit board copper side) the solder joints of the two "original" leads. If they are not shiny, reheat them and if necessary, apply additional solder.

Fuse and Conventional Resistor

Removal/Replacement

1. Clip each fuse or resistor lead at top of the circuit board hollow stake.
2. Securely crimp the leads of replacement component around notch at stake top.

3. Solder the connections.

CAUTION: Maintain original spacing between the replaced component and adjacent components and the circuit board to prevent excessive component temperatures.

Circuit Board Foil Repair

Excessive heat applied to the copper foil of any printed circuit board will weaken the adhesive that bonds the foil to the circuit board causing the foil to separate from or "lift-off" the board. The following guidelines and procedures should be followed whenever this condition is encountered.

At IC Connections

To repair a defective copper pattern at IC connections use the following procedure to install a jumper wire on the copper pattern side of the circuit board. (Use this technique only on IC connections).

1. Carefully remove the damaged copper pattern with a sharp knife. (Remove only as much copper as absolutely necessary).
2. Carefully scratch away the solder resist and acrylic coating (if used) from the end of the remaining copper pattern.
3. Bend a small "U" in one end of a small gauge jumper wire and carefully crimp it around the IC pin. Solder the IC connection.
4. Route the jumper wire along the path of the out-away copper pattern and let it overlap the previously scraped end of the good copper pattern. Solder the overlapped area and clip off any excess jumper wire.

At Other Connections

Use the following technique to repair the defective copper pattern at connections other than IC Pins. This technique involves the installation of a jumper wire on the component side of the circuit board.

1. Remove the defective copper pattern with a sharp knife. Remove at least 1/4 inch of copper, to ensure that a hazardous condition will not exist if the jumper wire opens.
2. Trace along the copper pattern from both sides of the pattern break and locate the nearest component that is directly connected to the affected copper pattern.
3. Connect insulated 20-gauge jumper wire from the lead of the nearest component on one side of the pattern break to the lead of the nearest component on the other side. Carefully crimp and solder the connections.
CAUTION: Be sure the insulated jumper wire is dressed so the it does not touch components or sharp edges.

SPECIFICATION

NOTE : Specifications and others are subject to change without notice for improvement.

1. Application range

This specification is applied to the LCD TV used LD23E chassis.

2. Requirement for Test

Each part is tested as below without special appointment.

- 1) Temperature: 25 °C ± 5 °C(77 °F ± 9 °F), CST: 40 °C ± 5 °C
- 2) Relative Humidity: 65 % ± 10 %
- 3) Power Voltage
: Standard input voltage (AC 100-240 V~, 50/60 Hz)
* Standard Voltage of each products is marked by models.
- 4) Specification and performance of each parts are followed each drawing and specification by part number in accordance with BOM.
- 5) The receiver must be operated for about 20 minutes prior to the adjustment.

3. Test method

- 1) Performance: LGE TV test method followed
- 2) Demanded other specification
 - Safety : CE, IEC specification
 - EMC : CE, IEC
 - Wireless : Wireless HD Specification (Option)

4. Model General Specification

No.	Item	Specification	Remarks
1	Market	EU(PAL Market-36Countries)	<p>DTV & Analog (Total 37 countries) DTV(MPEG2/4,DVB-T/T2/S) Albania/Austria/Belarus/Belgium/Bosnia/Bulgaria/Croatia/Czech/Estonia/France/Germany/Greece/Hungary/Ireland/Italy/Kazakhstan/Latvia/Lithuania/Luxembourg/Morocco/Netherlands/Poland/Portugal/Romania/Russia/Serbia/Slovenia/Spain/Slovakia/Switzerland/Turkey/UK/Ukraine/Denmark/Finland/Norway/Sweden</p> <p>Supported satellite : 29 satellites ABS1 75.0E/ AMOS 4.0W/ ASIASATS 105.5E/ ASTRA1L-HMKR 19.2E/ ASTRA2ABD 28.2E/ ASTRA3AB 23.5E/ ASTRA4A 4.8E/ ATLANTICBIRD2 8.0W/ ATLANTICBIRD3 5.0W/ BADR 26.0E/ EUROBIRD3 33.0E/ EUROBIRD9A 9.0E/ EUTELSATW2A 10.E/ EUTELSATW3A 7.0E/ EUTELSATW4W7 36.0E/ EUTELSESAT 16.0E/ EXPRESSAM1 40.0E/ EXPRESAM3 140.0E/ EXPRESSAM33 96.5E/ HELLASAT2 39.0E/ HISPASAT1CDE 30.0W/ HOTBIRD 13.0E/ INTELSAT10&7 68.5E/ INTELSAT15 85.2E/ INTELSAT904 60.0E/ NILESAT 7.0W/ THOR 0.8W/ TURKSAT 42.0E/ YAMAL201 90.0E</p>
2	Broadcasting system	1) PAL-BG 2) PAL-DK 3) PAL-I/I' 4) SECAM L/L', DK, BG, I 5) DVB-T 6) DVB-C 7) DVB-T2 8) DVB-S 9) DVB-S2	DVB-S: Satellite

No.	Item	Specification	Remarks
3	Receiving system	Analog : Upper Heterodyne Digital : COFDM, QAM	<ul style="list-style-type: none"> ▶ DVB-T <ul style="list-style-type: none"> - Guard Interval(Bitrate_Mbit/s) 1/4, 1/8, 1/16, 1/32 - Modulation : Code Rate QPSK : 1/2, 2/3, 3/4, 5/6, 7/8 16-QAM : 1/2, 2/3, 3/4, 5/6, 7/8 64-QAM : 1/2, 2/3, 3/4, 5/6, 7/8 ▶ DVB-T2 <ul style="list-style-type: none"> - Guard Interval(Bitrate_Mbit/s) 1/4, 1/8, 1/16, 1/32, 1/128, 19/128, 19/256, - Modulation : Code Rate QPSK : 1/2, 2/5, 2/3, 3/4, 5/6 16-QAM : 1/2, 2/5, 2/3, 3/4, 5/6 64-QAM : 1/2, 2/5, 2/3, 3/4, 5/6 256-QAM : 1/2, 2/5, 2/3, 3/4, 5/6 ▶ DVB-C <ul style="list-style-type: none"> - Symbolrate : 4.0Msymbols/s to 7.2Msymbols/s - Modulation : 16QAM, 64-QAM, 128-QAM and 256-QAM ▶ DVB-S/S2 <ul style="list-style-type: none"> - symbolrate DVB-S2 (8PSK / QPSK) : 2 ~ 45Msymbol/s DVB-S (QPSK) : 2 ~ 45Msymbol/s - viterbi DVB-S mode : 1/2, 2/3, 3/4, 5/6, 7/8 DVB-S2 mode : 1/2, 2/3, 3/4, 3/5, 4/5, 5/6, 8/9, 9/10
4	Input Voltage	AC 100 ~ 240V 50/60Hz	
5	Screen Size	46.96 inches	1046.68(H) x 594.02(V) x 1.5(D)mm (Typ.) FHD+240Hz
6	Aspect Ratio	16:9	
7	Tuning System		
8	Operating Environment	1) Temp : 0 ~ 40 deg 2) Humidity : ~ 80 %	
9	Storage Environment	1) Temp : -20 ~ 60 deg 2) Humidity : ~ 85 %	

5. Component Video Input (Y, CB/PB, CR/PR)

No.	Resolution	H-freq(kHz)	V-freq(Hz)	Pixel clock	Proposed
1	720*480	15.73	60	13.5135	SDTV ,DVD 480I
2	720*480	15.73	59.94	13.5	SDTV ,DVD 480I
3	720*480	31.50	60	27.027	SDTV 480P
4	720*480	31.47	59.94	27.0	SDTV 480P
5	1280*720	45.00	60.00	74.25	HDTV 720P
6	1280*720	44.96	59.94	74.176	HDTV 720P
7	1920*1080	33.75	60.00	74.25	HDTV 1080I
8	1920*1080	33.72	59.94	74.176	HDTV 1080I
9	1920*1080	67.500	60	148.50	HDTV 1080P
10	1920*1080	67.432	59.94	148.352	HDTV 1080P
11	1920*1080	27.000	24.000	74.25	HDTV 1080P
12	1920*1080	26.97	23.976	74.176	HDTV 1080P
13	1920*1080	33.75	30.000	74.25	HDTV 1080P
14	1920*1080	33.71	29.97	74.176	HDTV 1080P

6. RGB input (PC)

No.	Resolution	H-freq(kHz)	V-freq.(Hz)	Pixel clock(MHz)	Proposed	
						DDC
					PC	
1	640*350	31.468	70.09	25.17	EGA	X
2	720*400	31.469	70.08	28.32	DOS	O
3	640*480	31.469	59.94	25.17	VESA(VGA)	O
4	800*600	37.879	60.31	40.00	VESA(SVGA)	O
5	1024*768	48.363	60.00	65.00	VESA(XGA)	O
6	1360*768	47.712	60.015	85.50	VESA(WXGA)	X
7	1920*1080	67.5	60.00	148.5	WUXGA	O

7. HDMI Input

No.	Resolution	H-freq(kHz)	V-freq.(Hz)	Pixel clock(MHz)	VIC	Proposed	
HDMI-PC							
							DDC
1	720*400	31.468	70.08	28.321			X
2	640*480	31.469	59.94	25.17		VESA	O
3	800*600	37.879	60.31	40.00		VESA	O
4	1024*768	48.363	60.00	65.00		VESA(XGA)	O
5	1360*768	47.72	59.8	84.75		WXGA	O
6	1280*1024	63.595	60.0	108.875		SXGA	O
7	1920*1080	67.5	60.00	148.5		WUXGA	O
HDMI-DTV							
1	640*480	31.469 / 31.5	59.94/ 60	25.125	1	SDTV 480P	
2	720*480	31.469 / 31.5	59.94 / 60	27.00/27.03	2,3	SDTV 480P	
3	720*576	31.25	50	27	17,18	SDTV 576P	
4	720*576	15.625	50	27	21	SDTV 576I	
5	1280*720	37.500	50	74.25	19	HDTV 720P	
6	1280*720	44.96 / 45	59.94 / 60	74.17/74.25	4	HDTV 720P	
7	1920*1080	33.72 / 33.75	59.94 / 60	74.17/74.25	5	HDTV 1080I	
8	1920*1080	28.125	50.00	74.25	20	HDTV 1080I	
9	1920*1080	26.97 / 27	23.97 / 24	74.17/74.25	32	HDTV 1080P	
10	1920*1080		25		33	HDTV 1080P	
11	1920*1080	33.716 / 33.75	29.976 / 30.00	74.25	34	HDTV 1080P	
12	1920*1080	56.250	50	148.5	31	HDTV 1080P	
13	1920*1080	67.43 / 67.5	59.94 / 60	148.35/148.50	16	HDTV 1080P	

8. 3D Mode

8.1. RF Input

No.	Resolution	H-freq(kHz)	V-freq.(Hz)	Pixel clock(MHz)	Proposed	3D input proposed mode
1	1280*720	37.500	50	74.25	HDTV 720P	Side by Side, Top & Bottom
2	1920*1080	28.125	50	74.25	HDTV 1080I	Side by Side, Top & Bottom

8.2. HDMI Input

8.2.1. HDMI 1.3

No.	Resolution	H-freq(kHz)	V-freq.(kHz)	Pixel clock(MHz)	Proposed	3D input proposed mode
1	1280*720	45.00	60.00	74.25	HDTV 720P	Side by Side, Top & Bottom
2	1280*720	37.500	50	74.25	HDTV 720P	Side by Side, Top & Bottom
3	1920*1080	33.75	60.00	74.25	HDTV 1080I	Side by Side, Top & Bottom
4	1920*1080	28.125	50.00	74.25	HDTV 1080I	Side by Side, Top & Bottom
5	1920*1080	27.00	24.00	74.25	HDTV 1080P	Side by Side, Top & Bottom
6	1920*1080	33.75	30.00	74.25	HDTV 1080P	Side by Side, Top & Bottom
7	1920*1080	67.50	60.00	148.5	HDTV 1080P	Side by Side, Top & Bottom, Checkerboard, Single Frame Sequential
8	1920*1080	56.250	50	148.5	HDTV 1080P	Side by Side, Top & Bottom, Checkerboard, Single Frame Sequential

8.2.2. HDMI 1.4b

No.	Resolution	H-freq(kHz)	V-freq.(Hz)	Pixel clock(MHz)	VIC	3D input proposed mode	Proposed
1	640*480	31.469 / 31.5	59.94/ 60	25.125	1	Frame packing Line alternative Side-by-side(Full) Top-and-Bottom Side-by-side(half)	Secondary(SDTV 480P) (SDTV 480P) (SDTV 480P) Secondary(SDTV 480P) Secondary(SDTV 480P)
2	720*480	31.469 / 31.5	59.94 / 60	27.00/27.03	2,3	Frame packing Line alternative Side-by-side(Full) Top-and-Bottom Side-by-side(half)	Secondary(SDTV 480P) (SDTV 480P) (SDTV 480P) Secondary(SDTV 480P) Secondary(SDTV 480P)
3	720*576	31.25	50	27	17,18	Frame packing Line alternative Side-by-side(Full) Top-and-Bottom Side-by-side(half)	Secondary(SDTV 576P) (SDTV 576P) (SDTV 576P) Secondary(SDTV 576P) Secondary(SDTV 576P)
4	720*576	15.625	50	27	21	Frame packing Field alternative Side-by-side(Full) Top-and-Bottom Side-by-side(half)	Secondary(SDTV 576I) (SDTV 576I) (SDTV 576I) Secondary(SDTV 576I) Secondary(SDTV 576I)
5	1280*720	37.500	50	74.25	19	Frame packing Line alternative Side-by-side(Full) Top-and-Bottom Side-by-side(half)	Primary(HDTV 720P) (HDTV 720P) (HDTV 720P) Primary(HDTV 720P) Primary(HDTV 720P)
6	1280*720	44.96 / 45	59.94 / 60	74.17/74.25	4	Frame packing Line alternative Side-by-side(Full) Top-and-Bottom Side-by-side(half)	Primary(HDTV 720P) (HDTV 720P) (HDTV 720P) Primary(HDTV 720P) Primary(HDTV 720P)
7	1920*1080	33.72 / 33.75	59.94 / 60	74.17/74.25	5	Frame packing Field alternative Side-by-side(Full) Top-and-Bottom Side-by-side(half)	Primary(HDTV 1080I) (HDTV 1080I) (HDTV 1080I) Secondary(HDTV 1080I) Primary(HDTV 1080I)
8	1920*1080	28.125	50.00	74.25	20	Frame packing Field alternative Side-by-side(Full) Top-and-Bottom Side-by-side(half)	Primary(HDTV 1080I) (HDTV 1080I) (HDTV 1080I) Secondary(HDTV 1080I) Primary(HDTV 1080I)
9	1920*1080	26.97 / 27	23.97 / 24	74.17/74.25	32	Frame packing Line alternative Side-by-side(Full) Top-and-Bottom Side-by-side(half)	Primary(HDTV 1080P) (HDTV 1080P) (HDTV 1080P) Primary(HDTV 1080P) Primary(HDTV 1080P)
10	1920*1080		25		33	Frame packing Line alternative Side-by-side(Full) Top-and-Bottom Side-by-side(half)	Secondary(HDTV 1080P) (HDTV 1080P) (HDTV 1080P) Secondary(HDTV 1080P) Secondary(HDTV 1080P)
11	1920*1080	33.716 / 33.75	29.976 / 30.00	74.25	34	Frame packing Line alternative Side-by-side(Full) Top-and-Bottom Side-by-side(half)	(HDTV 1080P) (HDTV 1080P) (HDTV 1080P) (HDTV 1080P) Secondary(HDTV 1080P)
12	1920*1080	56.250	50	148.5	31	Top-and-Bottom Side-by-side(half)	Primary(HDTV 1080P) Secondary(HDTV 1080P)
13	1920*1080	67.43 / 67.5	59.94 / 60	148.35/148.50	16	Top-and-Bottom Side-by-side(half)	Primary(HDTV 1080P) Secondary(HDTV 1080P)

8.3. RGB-PC Input(3D)

No.	Resolution	H-freq(kHz)	V-freq.(Hz)	Pixel clock(MHz)	3D input proposed mode	Proposed
1	1920*1080	67.5	60	148.5	Side by Side, Top & Bottom	HDTV 1080P

8.4. Component Input(3D)

No.	Resolution	H-freq(kHz)	V-freq.(Hz)	Pixel clock	3D input proposed mode	Proposed
1	1280*720	45.00	60.00	74.25	Side by Side, Top & Bottom	HDTV 720P
2	1280*720	44.96	59.94	74.176	Side by Side, Top & Bottom	HDTV 720P
3	1920*1080	33.75	60.00	74.25	Side by Side, Top & Bottom	HDTV 1080I
4	1920*1080	33.72	59.94	74.176	Side by Side, Top & Bottom	HDTV 1080I
5	1920*1080	67.500	60	148.50	Side by Side, Top & Bottom	HDTV 1080P
6	1920*1080	67.432	59.94	148.352	Side by Side, Top & Bottom	HDTV 1080P
7	1920*1080	27.000	24.000	74.25	Side by Side, Top & Bottom	HDTV 1080P
8	1920*1080	26.97	23.976	74.176	Side by Side, Top & Bottom	HDTV 1080P
9	1920*1080	33.75	30.000	74.25	Side by Side, Top & Bottom	HDTV 1080P
10	1920*1080	33.71	29.97	74.176	Side by Side, Top & Bottom	HDTV 1080P





8.5. USB Input(3D)

No.	Resolution	H-freq(kHz)	V-freq.(Hz)	Pixel clock(MHz)	3D input proposed mode	Proposed
1	1920*1080	33.75	30.000	74.25	Side by Side, Top & Bottom, Checkerboard	HDTV 1080P

8.6. DLNA Input (3D)

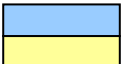
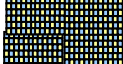
No.	Resolution	H-freq(kHz)	V-freq.(Hz)	Pixel clock(MHz)	3D input proposed mode	Proposed
1	1920*1080	33.75	30.000	74.25	Side by Side, Top & Bottom, Checkerboard	HDTV 1080P

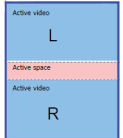
■ Remark: 3D Input mode

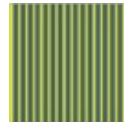
No.	Side by Side	Top & Bottom	Checker board	Single Frame Sequential	Frame Packing	Line Interleaving	Column Interleaving
1							

ADJUSTMENT INSTRUCTION

1. Application Range

This specification sheet is applied to all of the LED LCD TV with LD23E chassis.

2. Designation

- (1) Because this is not a hot chassis, it is not necessary to use an isolation transformer. However, the use of isolation transformer will help protect test instrument.
- (2) Adjustment must be done in the correct order.
- (3) The adjustment must be performed in the circumstance of 25 °C ± 5 °C of temperature and 65 % ± 10 % of relative humidity if there is no specific designation.
- (4) The input voltage of the receiver must keep AC 100-240 V~, 50/60 Hz.
- (5) The receiver must be operated for about 5 minutes prior to the adjustment when module is in the circumstance of over 15.

In case of keeping module is in the circumstance of 0 °C, it should be placed in the circumstance of above 15 °C for 2 hours.

In case of keeping module is in the circumstance of below -20 °C, it should be placed in the circumstance of above 15 °C for 3 hours.

[Caution]

When still image is displayed for a period of 20 minutes or longer (Especially where W/B scale is strong. Digital pattern 13ch and/or Cross hatch pattern 09ch), there can some afterimage in the black level area.

3. Automatic Adjustment

3.1. ADC Adjustment

3.1.1. Overview

ADC adjustment is needed to find the optimum black level and gain in Analog-to-Digital device and to compensate RGB deviation.

3.1.2. Equipment & Condition

- (1) USB to RS-232C Jig
- (2) MSPG-925 Series Pattern Generator(MSPG-925FA, pattern - 65)
 - Resolution : 480i Comp1
1080P Comp1
1920*1080 RGB
 - Pattern : Horizontal 100% Color Bar Pattern
 - Pattern level : 0.7 ± 0.1 Vp-p
 - Image

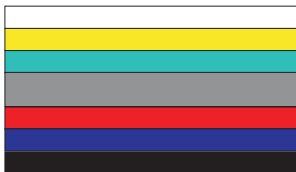

3.1.3. Adjustment

- (1) Adjustment method
 - Using RS-232, adjust items in the other shown in "3.1.3.3)"

- (2) Adj. protocol

Protocol	Command	Set ACK
Enter adj. mode	aa 00 00	a 00 OK00x
Source change	xb 00 04	b 00 OK04x (Adjust 480i, 1080p Comp1)
	xb 00 06	b 00 OK06x (Adjust 1920*1080 RGB)
Begin adj.	ad 00 10	
Return adj. result		OKx (Case of Success) NGx (Case of Fail)
Read adj. data	(main) ad 00 20	(main) 000000000000000000000000007c007b006dx
	(sub) ad 00 21	(Sub) 000000070000000000000000007c00830077x
Confirm adj.	ad 00 99	NG 03 00x (Fail) NG 03 01x (Fail) NG 03 02x (Fail) OK 03 03x (Success)
End adj.	aa 00 90	a 00 OK90x

Ref.) ADC Adj. RS232C Protocol_Ver1.0

- (3) Adj. order

- aa 00 00 [Enter ADC adj. mode]
- xb 00 04 [Change input source to Component1 (480i& 1080p)]
- ad 00 10 [Adjust 480i&1080p Comp1]
- xb 00 06 [Change input source to RGB(1024*768)]
- ad 00 10 [Adjust 1920*1080 RGB]
- ad 00 90 End adj.

3.2. MAC address D/L, CI+ key D/L, Widevine key D/L

Connect: PCBA Jig → RS-232C Port== PC → RS-232C Port
Communication Prot connection

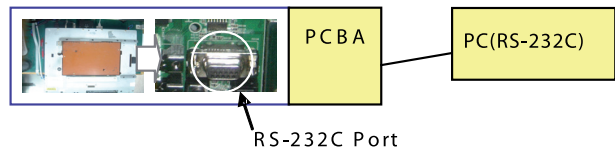

- Com 1,2,3,4 and 115200(Baudrate)
Mode check: Online Only
- Check the test process: DETECT → MAC → CI → Widevine → ESN
- Play: START
- Result: Ready, Test, OK or NG
- Printer Out (MAC Address Label)

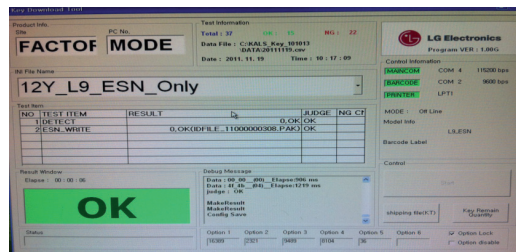

3.3. LAN Inspection

3.3.1. Equipment & Condition

- Each other connection to LAN Port of IP Hub and Jig

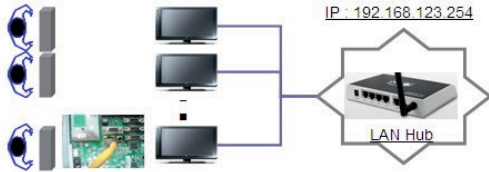

3.3.2. LAN inspection solution

- LAN Port connection with PCB
- Network setting at MENU Mode of TV
- Setting automatic IP
- Setting state confirmation
 - If automatic setting is finished, you confirm IP and MAC Address.

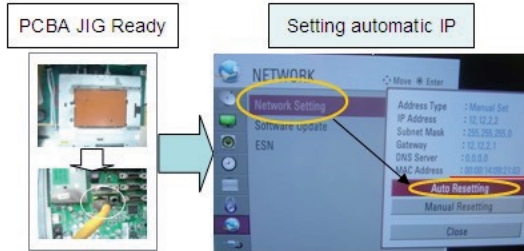

3.3.3. WIDEVINE key Inspection

- Confirm key input data at the "IN START" MENU Mode.

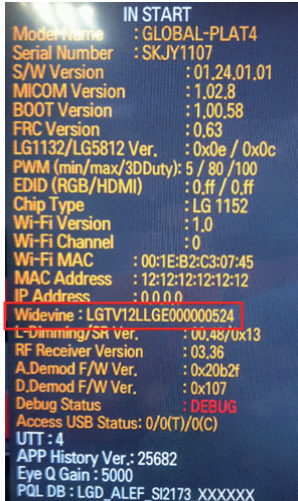

3.4. LAN PORT INSPECTION(PING TEST)

Connect SET → LAN port == PC → LAN Port



3.4.1. Equipment setting

- Play the LAN Port Test PROGRAM.
- Input IP set up for an inspection to Test Program.
 - *IP Number : 12.12.2.2

3.4.2. LAN PORT inspection(PING TEST)

- Play the LAN Port Test Program.
- Connect each other LAN Port Jack.
- Play Test (F9) button and confirm OK Message.
- Remove LAN cable.

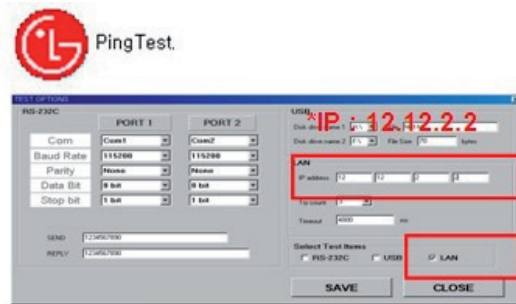

3.5. Model name & Serial number Download

3.5.1. Model name & Serial number D/L

- Press "Power on" key of service remote control. (Baud rate : 115200 bps)
- Connect RS232 Signal Cable to RS-232 Jack.
- Write Serial number by use RS-232.
- Must check the serial number at Instart menu.

3.5.2. Method & notice

- Serial number D/L is using of scan equipment.
- Setting of scan equipment operated by Manufacturing Technology Group.
- Serial number D/L must be conformed when it is produced in production line, because serial number D/L is mandatory by D-book 4.0

* Manual Download (Model Name and Serial Number)
 If the TV set is downloaded by OTA or service man, sometimes model name or serial number is initialized.(Not always)
 It is impossible to download by bar code scan, so It need Manual download.

- 1) Press the "Instart" key of Adjustment remote control.
- 2) Go to the menu "6.Model Number D/L" like below photo.
- 3) Input the Factory model name(ex 42LD450-TA) or Serial number like photo.

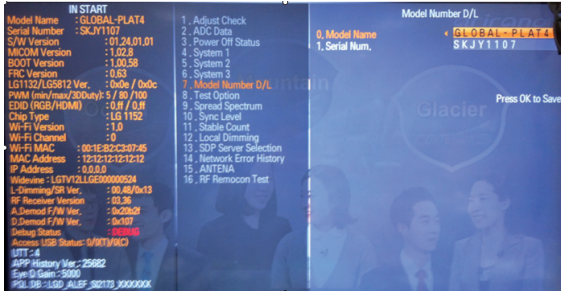

- 4) Check the model name Instart menu. → Factory name displayed. (ex 47LM960V-ZB)
- 5) Check the Diagnostics.(DTV country only) → Buyer model displayed. (ex 47LM960V-ZB)

3.6. CI+ Key checking method

- Check the Section 3.2
 Check whether the key was downloaded or not at 'In Start' menu. (Refer to below).



=> Check the Download to CI+ Key value in LGset.

3.6.1. Check the method of CI+ Key value

- (1) Check the method on Instart menu
- (2) Check the method of RS232C Command

1) Into the main ass'y mode(RS232: aa 00 00)

CMD 1	CMD 2	Data 0	
A	A	0	0

2) Check the key download for transmitted command (RS232: ci 00 10)

CMD 1	CMD 2	Data 0	
C	I	1	0

- 3) result value
- normally status for download : OKx
 - abnormally status for download : NGx

3.6.2. Check the method of CI+ key value(RS232)

1) Into the main ass'y mode(RS232: aa 00 00)

CMD 1	CMD 2	Data 0	
A	A	0	0

2) Check the method of CI+ key by command (RS232: ci 00 20)

CMD 1	CMD 2	Data 0	
C	I	2	0

3) Result value

i 01 OK 1d1852d21c1ed5dcx

→ CI+ Key Value

3.7. WIFI MAC ADDRESS CHECK

(1) Using RS232 Command

	H-freq(kHz)	V-freq.(Hz)
Transmission	[A][I][][Set ID][][20][Cr]	[O][K][X] or [NG]

(2) Check the menu on in-start

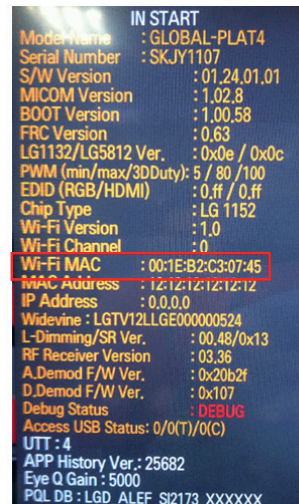

4. Manual Adjustment

* ADC adjustment is not needed because of OTP(Auto ADC adjustment)

4.1 EDID(The Extended Display Identification Data)/DDC(Display Data Channel) download

4.1.1. Overview

It is a VESA regulation. A PC or a MNT will display an optimal resolution through information sharing without any necessity of user input. It is a realization of "Plug and Play".

4.1.2. Equipment

- Since embedded EDID data is used, EDID download JIG, HDMI cable and D-sub cable are not need.
- Adjustment remote control

4.1.3. Download method

- (1) Press "ADJ" key on the Adjustment remote control then select "10.EDID D/L". By pressing "Enter" key, enter EDID D/L menu.
- (2) Select "Start" button by pressing "Enter" key, HDMI1/ HDMI2/ HDMI3/ HDMI4/ RGB are writing and display OK or NG.



4.1.4. EDID DATA

▪ HDMI(FHD 3D, HDMI 1.4a, 3D)

	0x00	0x01	0x02	0x03	0x04	0x05	0x06	0x07	0x08	0x09	0x0A	0x0B	0x0C	0x0D	0x0E	0x0F
0x00	00	FF	FF	FF	FF	FF	FF	00	1E	6D	Ⓐ		Ⓑ			
0x01	Ⓒ	01	03	80	A0	5A	78	0A	EE	91	A3	54	4C	99	26	
0x02	0F	50	54	A1	08	00	71	40	81	C0	81	00	81	80	95	00
0x03	90	40	A9	C0	B3	00	02	3A	80	18	71	38	2D	40	58	2C
0x04	45	00	A0	5A	00	00	00	1E	66	21	50	B0	51	00	1B	30
0x05	40	70	36	00	A0	5A	00	00	1E	00	00	00	00	FD	00	39
0x06	3F	1F	52	10	00	0A	20	20	20	20	20	20	Ⓓ			
0x07	Ⓔ														01	Ⓔ1
0x00	02	03	37	F1	4E	90	1F	04	13	05	14	03	02	12	20	21
0x01	22	15	01	26	15	07	50	09	57	07	Ⓕ					
0x02	Ⓖ															
0x03	Ⓖ															
0x04	2C	45	00	A0	5A	00	00	00	1E	01	1D	80	18	71	1C	16
0x05	20	58	2C	25	00	A0	5A	00	00	00	9E	01	1D	00	72	51
0x06	D0	1E	20	6E	28	55	00	A0	5A	00	00	00	1E	00	00	00
0x07	00	00	00	00	00	00	00	00	00	00	00	00	00	00	00	Ⓔ2

▪ RGB

	0x00	0x01	0x02	0x03	0x04	0x05	0x06	0x07	0x08	0x09	0x0A	0x0B	0x0C	0x0D	0x0E	0x0F
0x00	00	FF	FF	FF	FF	FF	FF	00	1E	6D	Ⓐ		Ⓑ			
0x01	Ⓒ	01	03	68	10	09	78	0A	EE	91	A3	54	4C	99	26	
0x02	0F	50	54	A1	08	00	71	40	81	C0	81	00	81	80	95	00
0x03	90	40	A9	C0	B3	00	02	3A	80	18	71	38	2D	40	58	2C
0x04	45	00	A0	5A	00	00	00	1E	66	21	50	B0	51	00	1B	30
0x05	40	70	36	00	A0	5A	00	00	1E	00	00	00	00	FD	00	3A
0x06	3E	1E	53	10	00	0A	20	20	20	20	20	20	Ⓓ			
0x07	Ⓔ														00	Ⓔ3

▪ Reference

- HDMI1 ~ HDMI4 / RGB
- In the data of EDID, bellows may be different by S/W or Input mode.

Ⓐ Product ID

Ⓑ Serial No: Controlled on production line.

Ⓒ Month, Year: Controlled on production line:

ex) Monthly : '01' → '01'
Year : '2012' → '16'

Ⓓ Model Name(Hex): LGTV

Ⓔ Checksum(LG TV): Changeable by total EDID data.

Ⓕ Vendor Specific(HDMI)

HDMI 1(C/S : 9D BA)

EDID Block 0, Bytes 0-127 [00H-7FH]

	0	1	2	3	4	5	6	7	8	9	A	B	C	D	E	F
00	00	FF	FF	FF	FF	FF	FF	00	1E	6D	01	00	01	01	01	01
10	01	16	01	03	80	A0	5A	78	0A	EE	91	A3	54	4C	99	26
20	0F	50	54	A1	08	00	31	40	45	40	61	40	71	40	81	80
30	01	01	01	01	01	01	02	3A	80	18	71	38	2D	40	58	2C
40	45	00	A0	5A	00	00	00	1E	66	21	50	B0	51	00	1B	30
50	40	70	36	00	A0	5A	00	00	00	1E	00	00	00	FD	00	39
60	3F	1F	52	10	00	0A	20	20	20	20	20	20	20	20	00	FC
70	00	4C	47	20	54	56	0A	20	20	20	20	20	20	20	01	43

EDID Block 1, Bytes 128-255 [80H-FFH]

	0	1	2	3	4	5	6	7	8	9	A	B	C	D	E	F
00	02	03	37	F1	4E	10	9F	04	13	05	14	03	02	12	20	21
10	22	15	01	26	15	07	50	09	57	07	78	03	0C	00	10	00
20	B8	2D	20	C0	0E	01	4F	3F	FC	08	10	18	10	06	10	16
30	10	28	10	E3	05	03	01	02	3A	80	18	71	38	2D	40	58
40	2C	45	00	A0	5A	00	00	00	1E	01	1D	80	18	71	1C	16
50	20	58	2C	25	00	A0	5A	00	00	00	9E	01	1D	00	72	51
60	D0	1E	20	6E	28	55	00	A0	5A	00	00	00	1E	00	00	00
70	00	00	00	00	00	00	00	00	00	00	00	00	00	00	00	11

HDMI 2(C/S : 9D AA)

EDID Block 0, Bytes 0-127 [00H-7FH]

	0	1	2	3	4	5	6	7	8	9	A	B	C	D	E	F
00	00	FF	FF	FF	FF	FF	FF	00	1E	6D	01	00	01	01	01	01
10	01	16	01	03	80	A0	5A	78	0A	EE	91	A3	54	4C	99	26
20	0F	50	54	A1	08	00	31	40	45	40	61	40	71	40	81	80
30	01	01	01	01	01	01	02	3A	80	18	71	38	2D	40	58	2C
40	45	00	A0	5A	00	00	00	1E	66	21	50	B0	51	00	1B	30
50	40	70	36	00	A0	5A	00	00	00	1E	00	00	00	FD	00	39
60	3F	1F	52	10	00	0A	20	20	20	20	20	20	20	20	00	FC
70	00	4C	47	20	54	56	0A	20	20	20	20	20	20	20	01	43

EDID Block 1, Bytes 128-255 [80H-FFH]

	0	1	2	3	4	5	6	7	8	9	A	B	C	D	E	F
00	02	03	37	F1	4E	10	9F	04	13	05	14	03	02	12	20	21
10	22	15	01	26	15	07	50	09	57	07	78	03	0C	00	10	00
20	B8	2D	20	C0	0E	01	4F	3F	FC	08	10	18	10	06	10	16
30	10	28	10	E3	05	03	01	02	3A	80	18	71	38	2D	40	58
40	2C	45	00	A0	5A	00	00	00	1E	01	1D	80	18	71	1C	16
50	20	58	2C	25	00	A0	5A	00	00	00	9E	01	1D	00	72	51
60	D0	1E	20	6E	28	55	00	A0	5A	00	00	00	1E	00	00	00
70	00	00	00	00	00	00	00	00	00	00	00	00	00	00	00	01

HDMI 3(C/S : 9D 9A)

EDID Block 0, Bytes 0-127 [00H-7FH]

	0	1	2	3	4	5	6	7	8	9	A	B	C	D	E	F
00	00	FF	FF	FF	FF	FF	FF	00	1E	6D	01	00	01	01	01	01
10	01	16	01	03	80	A0	5A	78	0A	EE	91	A3	54	4C	99	26
20	0F	50	54	A1	08	00	31	40	45	40	61	40	71	40	81	80
30	01	01	01	01	01	01	02	3A	80	18	71	38	2D	40	58	2C
40	45	00	A0	5A	00	00	00	1E	66	21	50	B0	51	00	1B	30
50	40	70	36	00	A0	5A	00	00	00	1E	00	00	00	FD	00	39
60	3F	1F	52	10	00	0A	20	20	20	20	20	20	00	00	00	FC
70	00	4C	47	20	54	56	0A	20	20	20	20	20	20	20	01	43

EDID Block 1, Bytes 128-255 [80H-FFH]

	0	1	2	3	4	5	6	7	8	9	A	B	C	D	E	F
00	02	03	37	F1	4E	10	9F	04	13	05	14	03	02	12	20	21
10	22	15	01	26	15	07	50	09	57	07	78	03	0C	00	30	00
20	B8	2D	20	C0	0E	01	4F	3F	FC	08	10	18	10	06	10	16
30	10	28	10	E3	05	03	01	02	3A	80	18	71	38	2D	40	58
40	2C	45	00	A0	5A	00	00	00	1E	01	1D	80	18	71	1C	16
50	20	58	2C	25	00	A0	5A	00	00	00	9E	01	1D	00	72	51
60	D0	1E	20	6E	28	55	00	A0	5A	00	00	00	1E	00	00	00
70	00	00	00	00	00	00	00	00	00	00	00	00	00	00	00	F1

HDMI 4(C/S : 9D 8A)

EDID Block 0, Bytes 0-127 [00H-7FH]

	0	1	2	3	4	5	6	7	8	9	A	B	C	D	E	F
00	00	FF	FF	FF	FF	FF	FF	00	1E	6D	01	00	01	01	01	01
10	01	16	01	03	80	A0	5A	78	0A	EE	91	A3	54	4C	99	26
20	0F	50	54	A1	08	00	31	40	45	40	61	40	71	40	81	80
30	01	01	01	01	01	01	02	3A	80	18	71	38	2D	40	58	2C
40	45	00	A0	5A	00	00	00	1E	66	21	50	B0	51	00	1B	30
50	40	70	36	00	A0	5A	00	00	00	1E	00	00	00	FD	00	39
60	3F	1F	52	10	00	0A	20	20	20	20	20	20	00	00	00	FC
70	00	4C	47	20	54	56	0A	20	20	20	20	20	20	20	01	43

EDID Block 1, Bytes 128-255 [80H-FFH]

	0	1	2	3	4	5	6	7	8	9	A	B	C	D	E	F
00	02	03	37	F1	4E	10	9F	04	13	05	14	03	02	12	20	21
10	22	15	01	26	15	07	50	09	57	07	78	03	0C	00	40	00
20	B8	2D	20	C0	0E	01	4F	3F	FC	08	10	18	10	06	10	16
30	10	28	10	E3	05	03	01	02	3A	80	18	71	38	2D	40	58
40	2C	45	00	A0	5A	00	00	00	1E	01	1D	80	18	71	1C	16
50	20	58	2C	25	00	A0	5A	00	00	00	9E	01	1D	00	72	51
60	D0	1E	20	6E	28	55	00	A0	5A	00	00	00	1E	00	00	00
70	00	00	00	00	00	00	00	00	00	00	00	00	00	00	00	E1

RGB(C/S : 97)

	0	1	2	3	4	5	6	7	8	9	A	B	C	D	E	F
00	00	FF	FF	FF	FF	FF	FF	00	1E	6D	01	00	01	01	01	01
10	01	16	01	03	80	A0	5A	78	0A	EE	91	A3	54	4C	99	26
20	0F	50	54	A1	08	00	31	40	45	40	61	40	71	40	81	80
30	01	01	01	01	01	01	02	3A	80	18	71	38	2D	40	58	2C
40	45	00	A0	5A	00	00	00	1E	66	21	50	B0	51	00	1B	30
50	40	70	36	00	A0	5A	00	00	00	1E	00	00	00	FD	00	3A
60	3E	1E	53	10	00	0A	20	20	20	20	20	20	00	00	00	FC
70	00	4C	47	20	54	56	0A	20	20	20	20	20	20	20	00	5C

4.2. White Balance Adjustment

4.2.1. Overview

▪ W/B adj. Objective & How-it-works

- (1) Objective: To reduce each Panel's W/B deviation
- (2) How-it-works : When R/G/B gain in the OSD is at 192, it means the panel is at its Full Dynamic Range. In order to prevent saturation of Full Dynamic range and data, one of R/G/B is fixed at 192, and the other two is lowered to find the desired value.
- (3) Adjustment condition : normal temperature
 - 1) Surrounding Temperature : 25 °C ± 5 °C
 - 2) Warm-up time: About 5 Min
 - 3) Surrounding Humidity : 20 % ~ 80 %

4.2.2. Equipment

- (1) Color Analyzer: CA-210 (LED Module : CH 14)
 - (2) Adjustment Computer(During auto adj., RS-232C protocol is needed)
 - (3) Adjustment Remote control
 - (4) Video Signal Generator MSPG-925F 720p/216-Gray (Model: 217, Pattern: 78)
 - > Only when internal pattern is not available
- Color Analyzer Matrix should be calibrated using CS-1000.

4.2.3. Equipment connection MAP

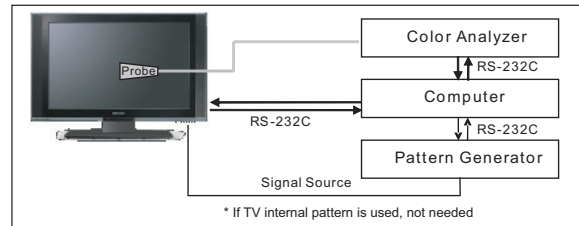

4.2.4. Adj. Command (Protocol)

<Command Format>

START	6E	A	50	A	LEN	A	03	A	CMD	A	00	A	VAL	A	CS	STOP
-------	----	---	----	---	-----	---	----	---	-----	---	----	---	-----	---	----	------

- LEN: Number of Data Byte to be sent
 - CMD: Command
 - VAL: FOS Data value
 - CS: Checksum of sent data
 - A: Acknowledge
- Ex) [Send: JA_00_DD] / [Ack: A_00_okDDX]

▪ RS-232C Command used during auto-adjustment.

RS-232C COMMAND [CMD ID DATA]			Explanation
wb	00	00	Begin White Balance adjustment
wb	00	10	Gain adjustment(internal white pattern)
wb	00	1f	Gain adjustment completed
wb	00	20	Offset adjustment(internal white pattern)
wb	00	2f	Offset adjustment completed
wb	00	ff	End White Balance adjustment (internal pattern disappears)

- Ex) wb 00 00 → Begin white balance auto-adj.
 wb 00 10 → Gain adj.
 ja 00 ff → Adj. data
 jb 00 c0
 ...
 ...
 wb 00 1f → Gain adj. completed
 *(wb 00 20(Start), wb 00 2f(end)) → Off-set adj.
 wb 00 ff → End white balance auto-adj.

▪ Adj. Map

	Adj. item	Command (lower caseASCII)		Data Range (Hex.)		Default (Decimal)
		CMD1	CMD2	MIN	MAX	
Cool	R Gain	j	g	00	C0	
	G Gain	j	h	00	C0	
	B Gain	j	i	00	C0	
	R Cut					
	G Cut					
	B Cut					
Medium	R Gain	j	a	00	C0	
	G Gain	j	b	00	C0	
	B Gain	j	c	00	C0	
	R Cut					
	G Cut					
	B Cut					
Warm	R Gain	j	d	00	C0	
	G Gain	j	e	00	C0	
	B Gain	j	f	00	C0	
	R Cut					
	G Cut					

4.2.5. Adj. method

(1) Auto adj. method

- 1) Set TV in adj. mode using POWER ON key.
- 2) Zero calibrate probe then place it on the center of the Display.
- 3) Connect Cable.(RS-232C to USB)
- 4) Select mode in adj. Program and begin adj.
- 5) When adj. is complete (OK Sign), check adj. status pre mode. (Warm, Medium, Cool)
- 6) Remove probe and RS-232C cable to complete adj.
 - W/B Adj. must begin as start command “wb 00 00” , and finish as end command “wb 00 ff”, and Adj. offset if need.

(2) Manual adjustment. method

- 1) Set TV in Adj. mode using POWER ON.
- 2) Zero Calibrate the probe of Color Analyzer, then place it on the center of LCD module within 10 cm of the surface.
- 3) Press ADJ key → EZ adjust using adj. R/C → 7. White-Balance then press the cursor to the right(key ►). (When right key(►) is pressed 216 Gray internal pattern will be displayed)
- 4) One of R Gain / G Gain / B Gain should be fixed at 192, and the rest will be lowered to meet the desired value.
- 5) Adjustment is performed in COOL, MEDIUM, WARM 3 modes of color temperature.
 - If internal pattern is not available, use RF input. In EZ Adj. menu 7.White Balance, you can select one of 2 Test-pattern: ON, OFF. Default is inner(ON). By selecting OFF, you can adjust using RF signal in 216 Gray pattern.

▪ Adjustment condition and cautionary items

- 1) Lighting condition in surrounding area
 Surrounding lighting should be lower 10 lux. Try to isolate adj. area into dark surrounding.
- 2) Probe location
 : Color Analyzer(CA-210) probe should be within 10 cm and perpendicular of the module surface (80° ~ 100°)
- 3) Aging time
 - After Aging Start, Keep the Power ON status during 5 Minutes.
 - In case of LCD, Back-light on should be checked using no signal or Full-white pattern.

4.2.6. Reference(White balance adjustment coordinate and color temperature)

- Luminance : 216 Gray
- Standard color coordinate and temperature using CS-1000 (over 26 inch)

Mode	Coordinate		Temp	Δuv
	x	y		
Cool	0.269	0.273	13000 K	0.0000
Medium	0.285	0.293	9300 K	0.0000
Warm	0.313	0.329	6500 K	0.0000

- Standard color coordinate and temperature using CA-210(CH 9)

Mode	Coordinate		Temp	Δuv
	x	y		
Cool	0.269 ± 0.002	0.273 ± 0.002	13000K	0.0000
Medium	0.285 ± 0.002	0.293 ± 0.002	9300K	0.0000
Warm	0.313 ± 0.002	0.329 ± 0.002	6500K	0.0000

4.2.7. ALELF & EDGE LED White balance table

- EDGE LED module change color coordinate because of aging time.
- Apply under the color coordinate table, for compensated aging time.
- ALEF(LM860*)

GP4	Aging time (Min)	Cool		Medium		Warm	
		X	y	x	y	x	y
		269	273	285	293	313	329
1	0-2	293	305	309	323	330	348
2	3-5	292	303	308	321	330	347
3	6-9	291	302	307	320	329	346
4	10-19	288	298	304	316	326	342
5	20-35	286	295	302	313	324	339
6	36-49	285	293	301	311	322	337
7	50-79	283	291	299	309	321	335
8	80-149	282	289	298	308	320	334
9	Over 150	281	287	298	306	319	332

4.3. EYE-Q function check

- (1) Turn on TV.
- (2) Press EYE key of Adjustment remote control.

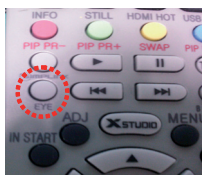

- (3) Cover the Eye Q II sensor on the front of the using your hand and wait for 6 seconds.



- (4) Confirm that R/G/B value is lower than 10 of the "Raw Data (Sensor data, Back light)". If after 6 seconds, R/G/B value is not lower than 10, replace Eye Q II sensor.



- (5) Remove your hand from the Eye Q II sensor and wait for 6 seconds.

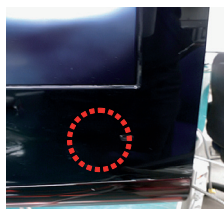

- (6) Confirm that "ok" pop up. If change is not seen, replace Eye Q II sensor.



4.4. Local Dimming Function Check

- Step 1) Turn on TV.
- Step 2) At the Local Dimming mode, module Edge Backlight moving right to left Back light of IOP module moving.
- Step 3) Confirm the Local Dimming mode.
- Step 4) Press "exit" key.

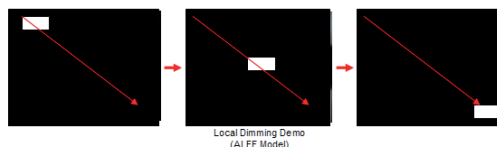

4.5. Magic Motion Remote control test

- (1) Equipment : RF Remote control for test, IR-KEY-Code Remote control for test
- (2) You must confirm the battery power of RF-Remote control before test(recommend that change the battery per every lot)
- (3) Sequence (test)
 - 1) if you select the "Start(Mute)" key on the Adjustment remote control, you can pairing with the TV SET.
 - 2) You can check the cursor on the TV Screen, when select the "OK" key on the Adjustment remote control.
 - 3) You must remove the pairing with the TV Set by select "OK" key + "Mute" key on the Adjustment remote control for 5 seconds.

4.6. 3D function test

- (Pattern Generator MSHG-600, MSPG-6100[Support HDMI1.4])
 * HDMI mode NO. 872 , pattern No.83
- (1) Please input 3D test pattern like below.



- (2) When 3D OSD appear automatically, then select OK key.



- (3) Don't wear a 3D Glasses, check the picture like below.



4.7. Wi-Fi Test

Step 1) Turn on TV

Step 2) Select Network Connection option in Network Menu.



Step 3) Select Start Connection button in Network Connection.



Step 4) If the system finds any AP like blow PIC, it is working well.

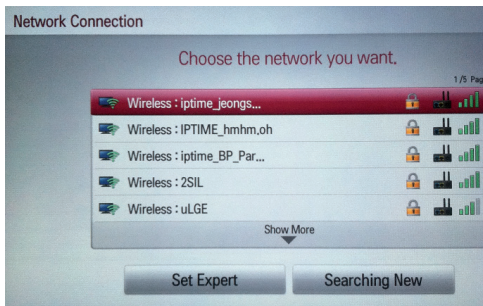

4.8. LNB voltage and 22KHz tone check

(only for DVB-S/S2 model)

▪ Test method

- (1) Set TV in Adj. mode using POWER ON.
- (2) Connect cable between satellite ANT and test JIG.
- (3) Press Yellow key(ETC+SWAP) in Adj Remote control to make LNB on.
- (4) Check LED light 'ON' at 18 V menu.
- (5) Check LED light 'ON' at 22 KHz tone menu.
- (6) Press Blue key(ETC+PIP INPUT) in Adj Remote control to make LNB off.
- (7) Check LED light 'OFF' at 18 V menu.
- (8) Check LED light 'OFF' at 22 KHz tone menu.

▪ Test result

- (1) After press LNB On key, '18 V LED' and '22 KHz tone LED' should be ON.
- (2) After press LNB OFF key, '18 V LED' and '22 KHz tone LED' should be OFF.

4.9. Inspection of light scattering

▪ Test Method

- (1) Push "Power only" key.
- (2) Push "HDMI" hot key.
- (3) Inspect whether light scattering is occurred in internal black pattern or not.
- (4) Push "Power only" key.

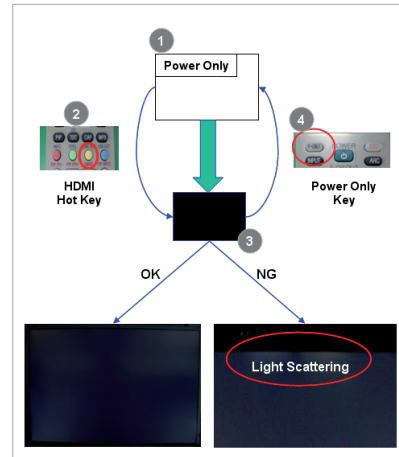

4.10. Option selection per country

4.10.1. Overview

- Option selection is only done for models in Non-EU

4.10.2. Method

- (1) Press ADJ key on the Adj. R/C, then select Country Group Meun
- (2) Depending on destination, select Country Group Code 04 or Country Group EU then on the lower Country option, select US, CA, MX. Selection is done using +, - or ►◀ key.

4.11. MHL Test

- (1) Turn on TV
- (2) Select HDMI4 mode using input Menu.
- (3) Set MHL Zig(M1S0D3617) using MHL input, output and power cord.
- (4) Connect HDMI cable between MHL Zig and HDMI4 port.
- (5) Check LED light of Zig and Module of Set.

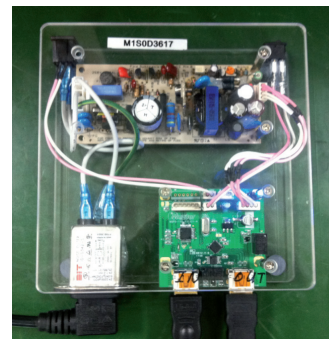

Result) If, The LED light is green and The Module shows normal stream → OK, Else → NG

5. Tool Option selection

- Method : Press "ADJ" key on the Adjustment remote control, then select Tool option.

6. Ship-out mode check(In-stop)

- After final inspection, press "IN-STOP" key of the Adjustment remote control and check that the unit goes to Stand-by mode.

7. GND and Internal Pressure check

7.1. Method

- GND & Internal Pressure auto-check preparation
 - Check that Power cord is fully inserted to the SET. (If loose, re-insert)
- Perform GND & Internal Pressure auto-check
 - Unit fully inserted Power cord, Antenna cable and A/V arrive to the auto-check process.
 - Connect D-terminal to AV JACK TESTER
 - Auto CONTROLLER(GWS103-4) ON
 - Perform GND TEST
 - If NG, Buzzer will sound to inform the operator.
 - If OK, changeover to I/P check automatically. (Remove CORD, A/V form AV JACK BOX.)
 - Perform I/P test
 - If NG, Buzzer will sound to inform the operator.
 - If OK, Good lamp will lit up and the stopper will allow the pallet to move on to next process.

7.2. Checkpoint

- TEST voltage
 - GND: 1.5 KV / min at 100 mA
 - SIGNAL: 3 KV / min at 100 mA
- TEST time: 1 second
- TEST POINT
 - GND TEST = POWER CORD GND & SIGNAL CABLE METAL GND
 - Internal Pressure TEST = POWER CORD GND & LIVE & NEUTRAL
- LEAKAGE CURRENT: At 0.5 mArms

8. Audio

No.	Item	Min	Typ	Max	Unit	Remark
1.	Audio practical max Output, L/R (Distortion=10% max Output)	9.0	10.0	12.0	W	Measurement condition Auto Volume :Off Audio EQ : Off Clear Voice : Off Virtual Surround:Off
		8.5	8.9	9.8	Vrms	
2.	Speaker (8Ω Impedance)		10.0	15.0	W	

Measurement condition:

- RF input: Mono, 1 KHz sine wave signal, 100 % Modulation
- CVBS, Component: 1 KHz sine wave signal 0.5 Vrms
- RGB PC: 1 KHz sine wave signal 0.7 Vrms

9. USB S/W Download(Service only)

- Put the USB Stick to the USB socket.
- Automatically detecting update file in USB Stick.
 - If your downloaded program version in USB Stick is Low, it didn't work. But your downloaded version is High, USB data is automatically detecting.(Download Version High & Power only mode, Set is automatically Download)
- Show the message "Copying files from memory".

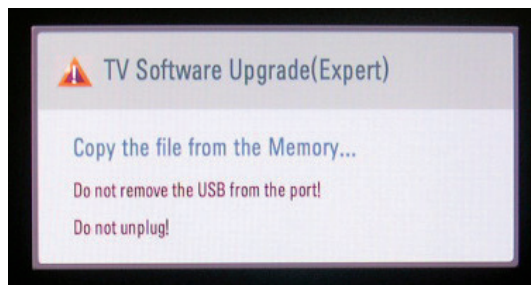

- Updating is starting.
- Updating Completed, The TV will restart automatically.

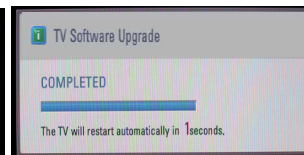
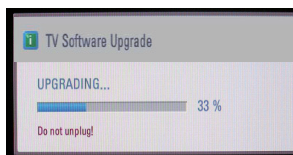

- If your TV is turned on, check your updated version and Tool option. (explain the Tool option, next stage)
- * If downloading version is more high than your TV have, TV can lost all channel data. In this case, you have to channel recover. if all channel data is cleared, you didn't have a DTV/ ATV test on production line.

- * After downloading, have to adjust Tool Option again.
- Push "IN-START" key in service remote control.
 - Select "Tool Option 1" and push "OK" key.
 - Punch in the number. (Each model has their number)

EXPLODED VIEW

IMPORTANT SAFETY NOTICE

Many electrical and mechanical parts in this chassis have special safety-related characteristics. These parts are identified by Δ in the Schematic Diagram and EXPLODED VIEW. It is essential that these special safety parts should be replaced with the same components as recommended in this manual to prevent X-RADIATION, Shock, Fire, or other Hazards. Do not modify the original design without permission of manufacturer.

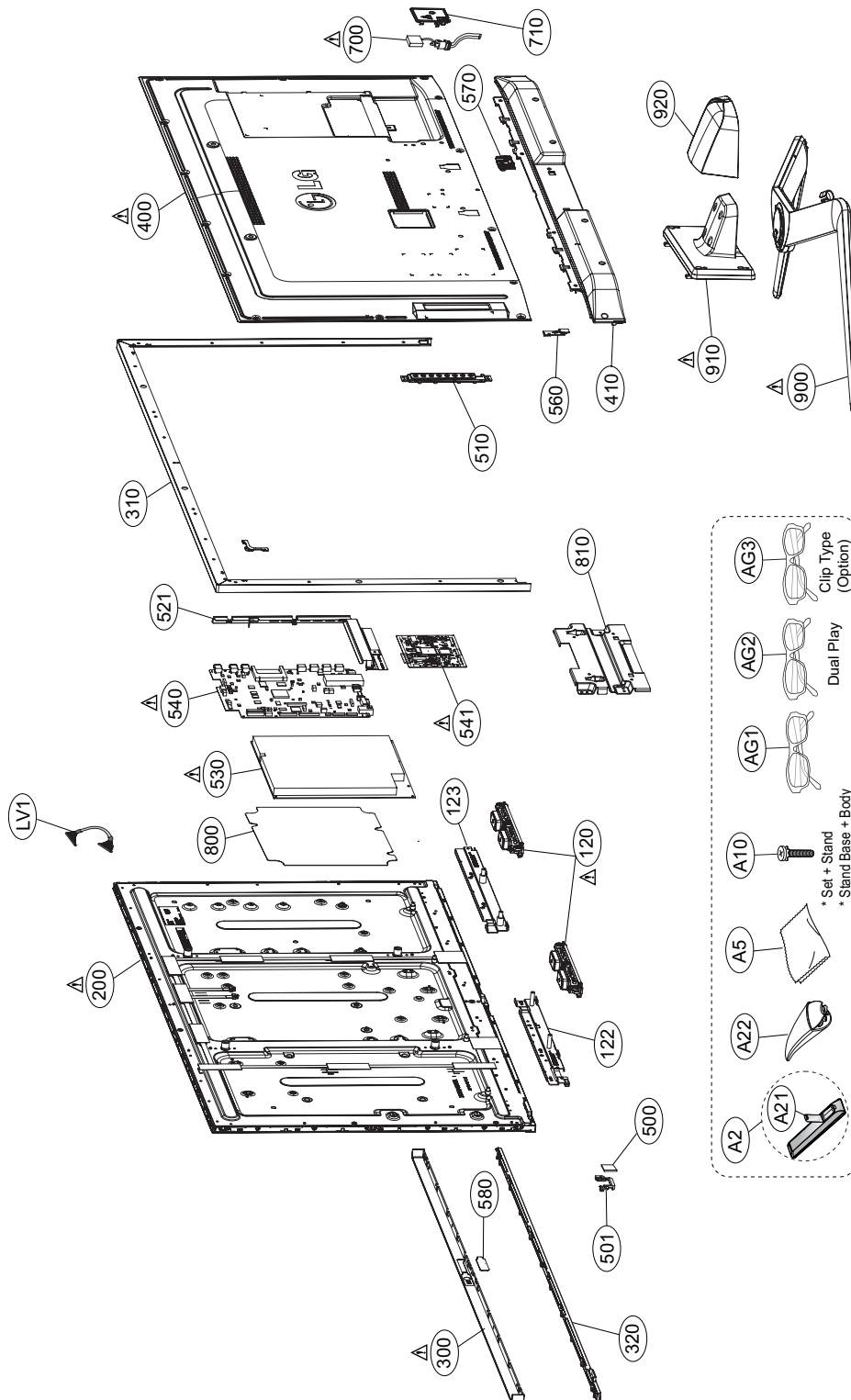

System Configuration

Clock for LG1152

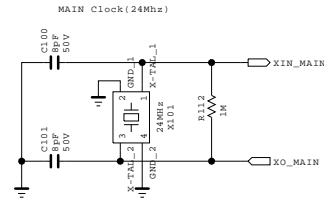

```

PLL SET[1:0] ==> Internal Pull-Up. N.C is high
00 : CPU clock(1056MHz), Main0,1/2 DDR (792/792 Mhz)
01 : CPU clock(792MHz), Main0,1/2 DDR (672/672 Mhz)
10 : CPU clock(1152MHz), Main0,1/2 DDR (792/672 Mhz)
11 : CPU clock(984MHz), Main0,1/2 DDR (792/792 Mhz)
    
```

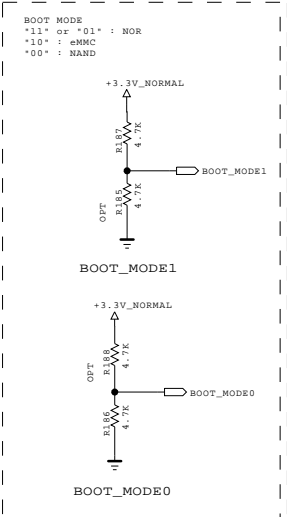
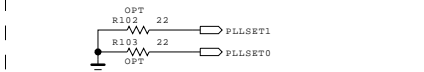

JTAG I/F FOR MAIN

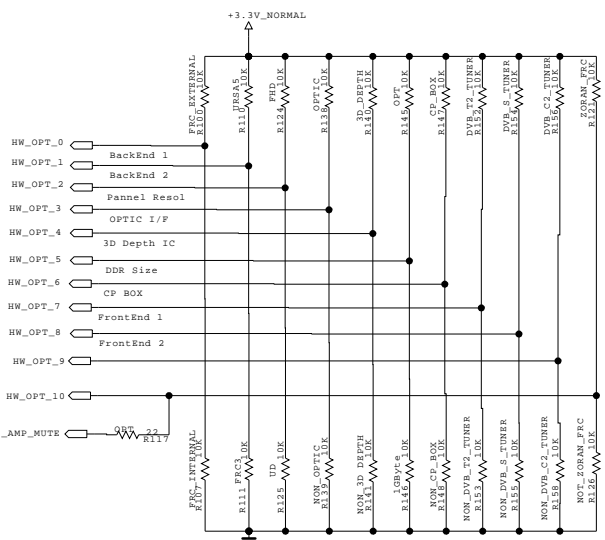
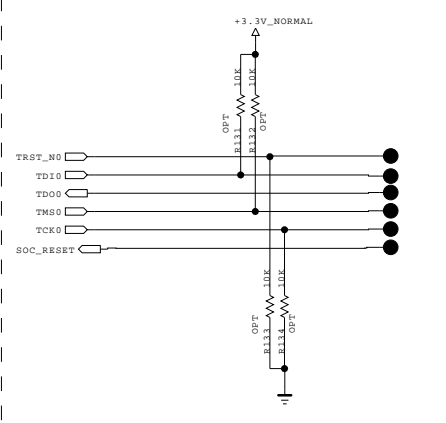

THE SYMBOL MARK OF THIS SCHEMATIC DIAGRAM INCORPORATES SPECIAL FEATURES IMPORTANT FOR PROTECTION FROM X-RADIATION. FILRE AND ELECTRICAL SHOCK HAZARDS, WHEN SERVICING IF IS ESSENTIAL THAT ONLY MANUFACTURES SPECIFIED PARTS BE USED FOR THE CRITICAL COMPONENTS IN THE SYMBOL MARK OF THE SCHEMATIC.

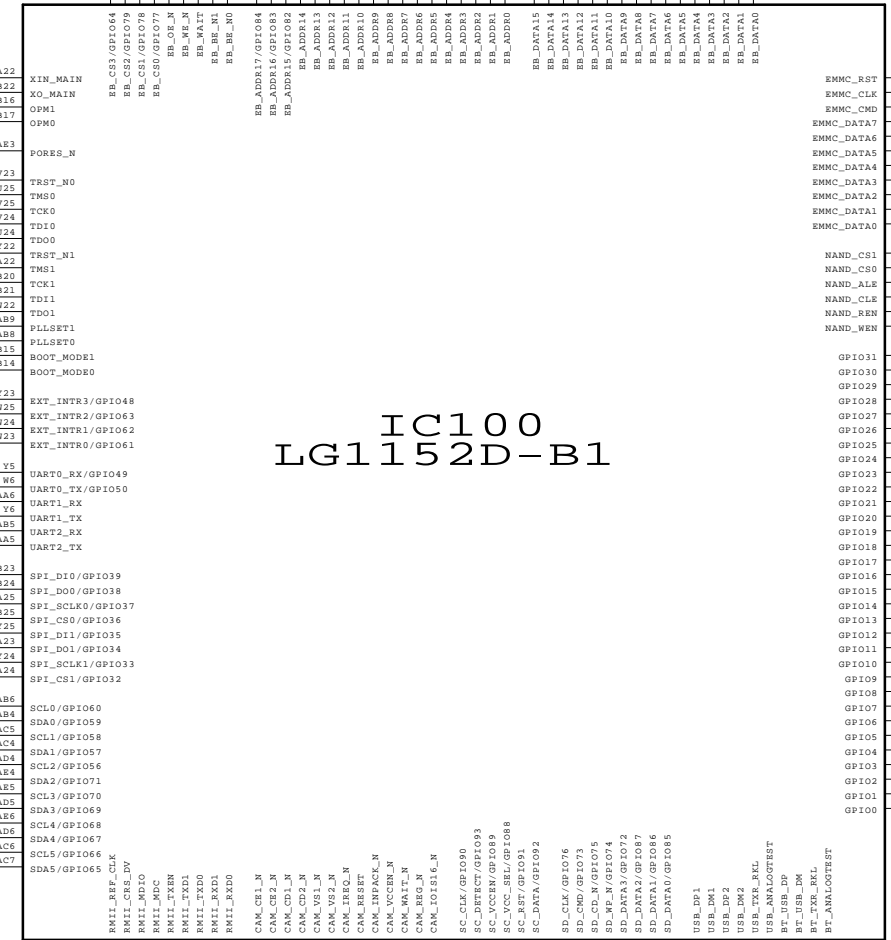
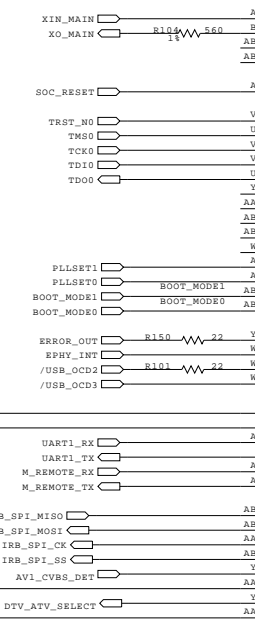
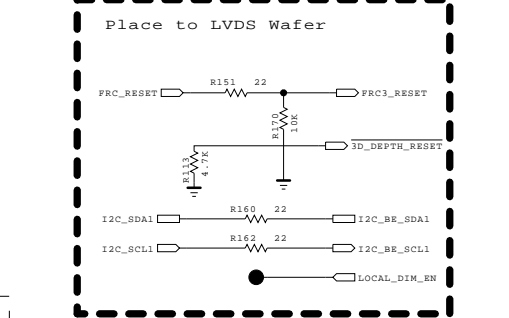
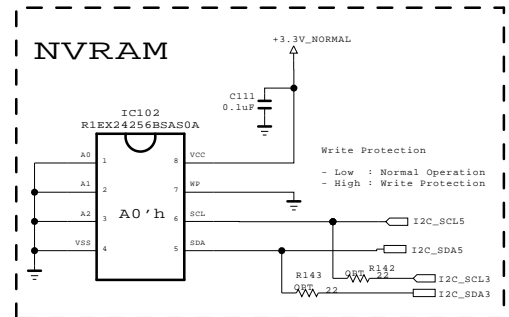

IC100 LG1152D-B1

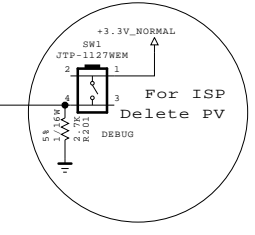
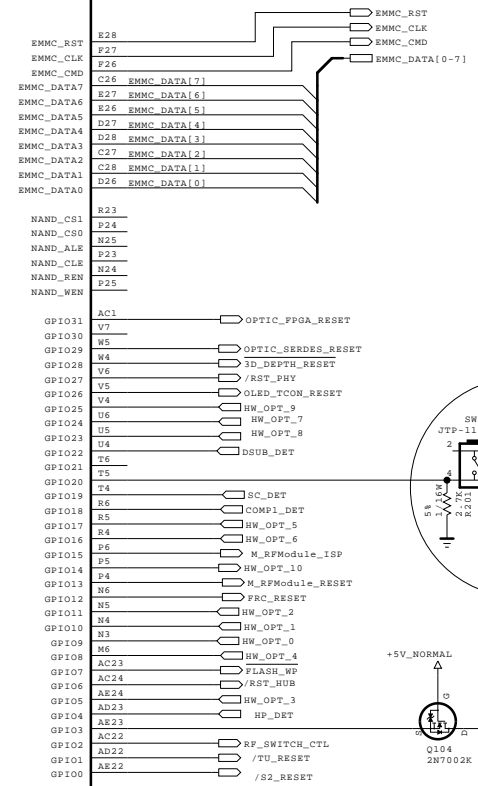
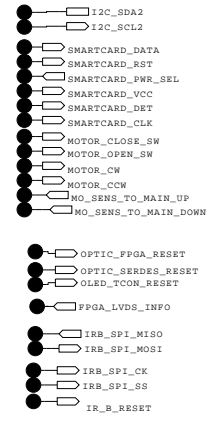
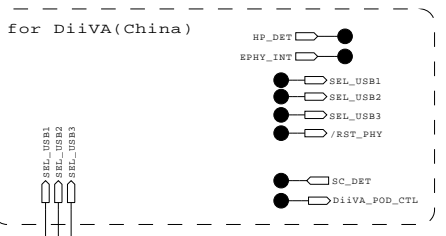
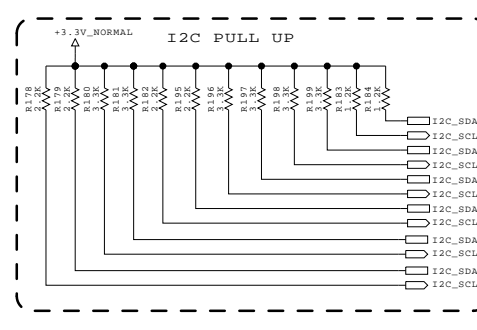

Debug

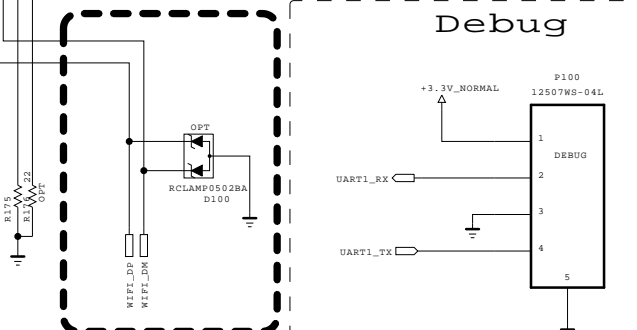

Place near Jack side			
MODEL	LG1152 B1	DATE	
BLOCK	MAIN & GPIO	SHEET	1

SECRET
LGElectronics



LG1152A

IC101
LG1152AN-B2

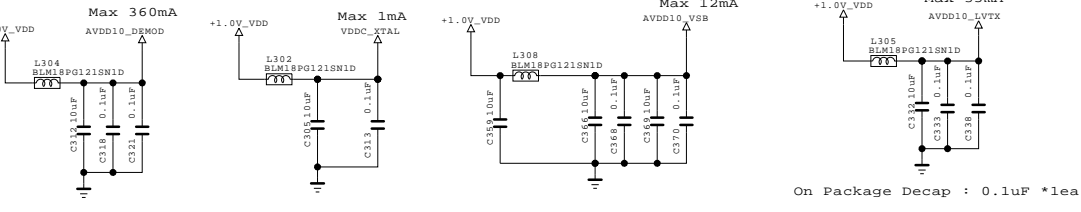
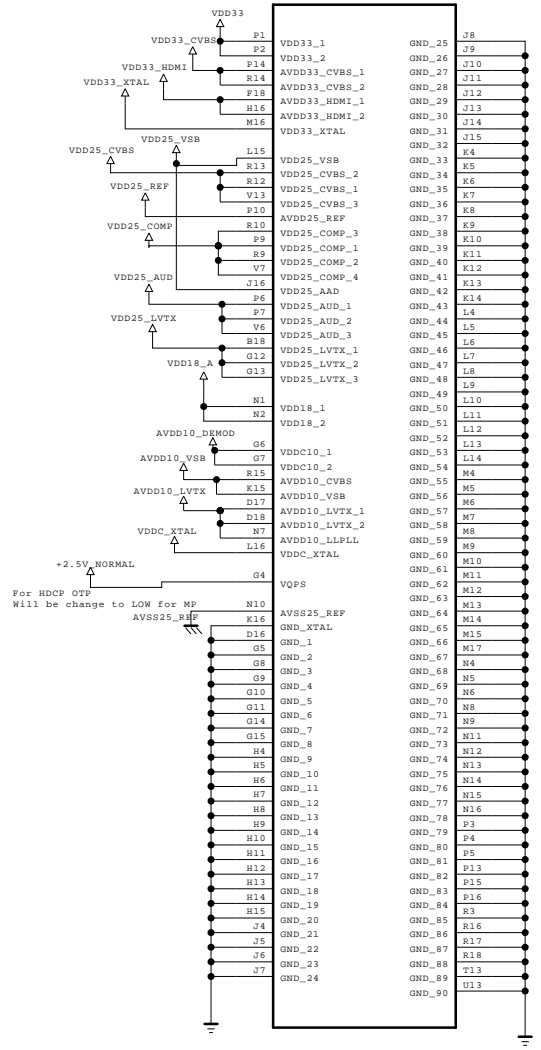

On Package Decap : 0.1uF *1ea

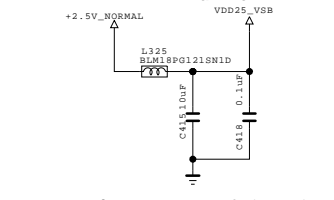
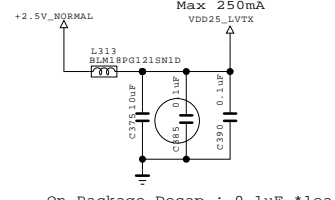
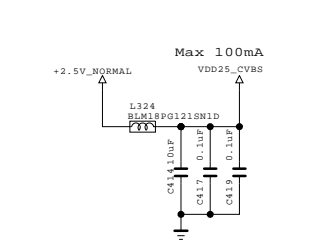
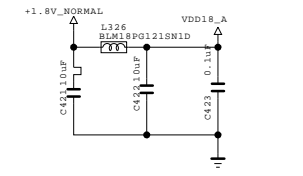

On Package Decap : 0.1uF *1ea

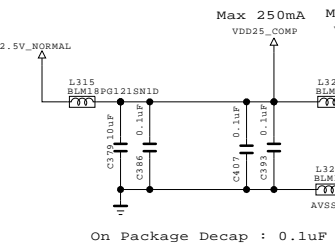
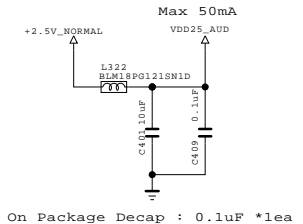

On Package Decap : 0.1uF *1ea

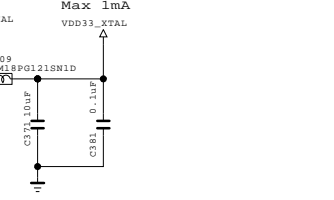
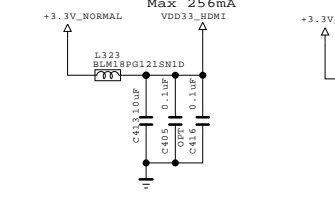
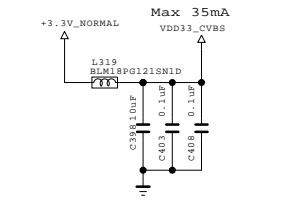

On Package Decap : 0.1uF *1ea

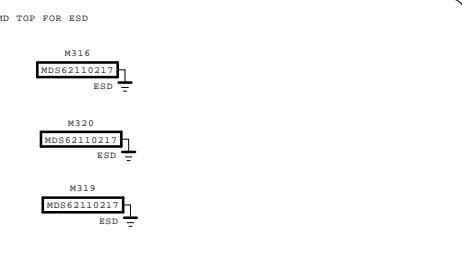
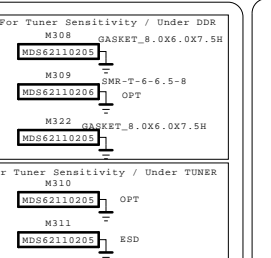
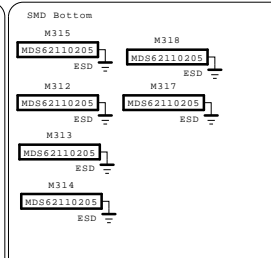
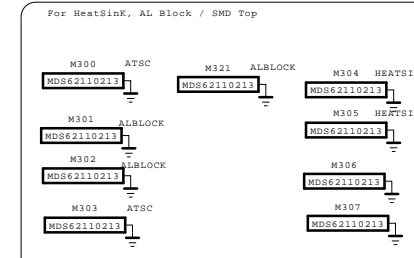

THE Δ SYMBOL MARK OF THIS SCHEMATIC DIAGRAM INCORPORATES SPECIAL FEATURES IMPORTANT FOR PROTECTION FROM X-RADIATION. FILRE AND ELECTRICAL SHOCK HAZARDS, WHEN SERVICING IF IS ESSENTIAL THAT ONLY MANUFACTURES SPECIFIED PARTS BE USED FOR THE CRITICAL COMPONENTS IN THE Δ SYMBOL MARK OF THE SCHEMATIC.

SECRET
LGElectronics



LG1152D

IC100
LG1152D-B1

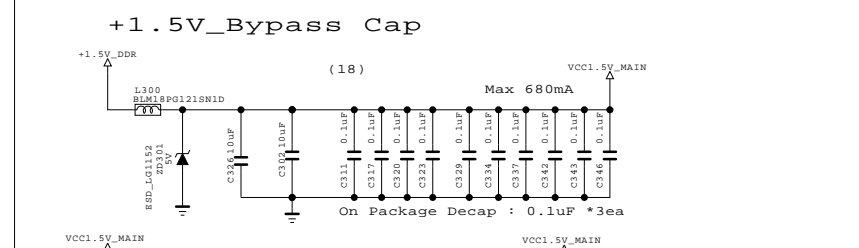
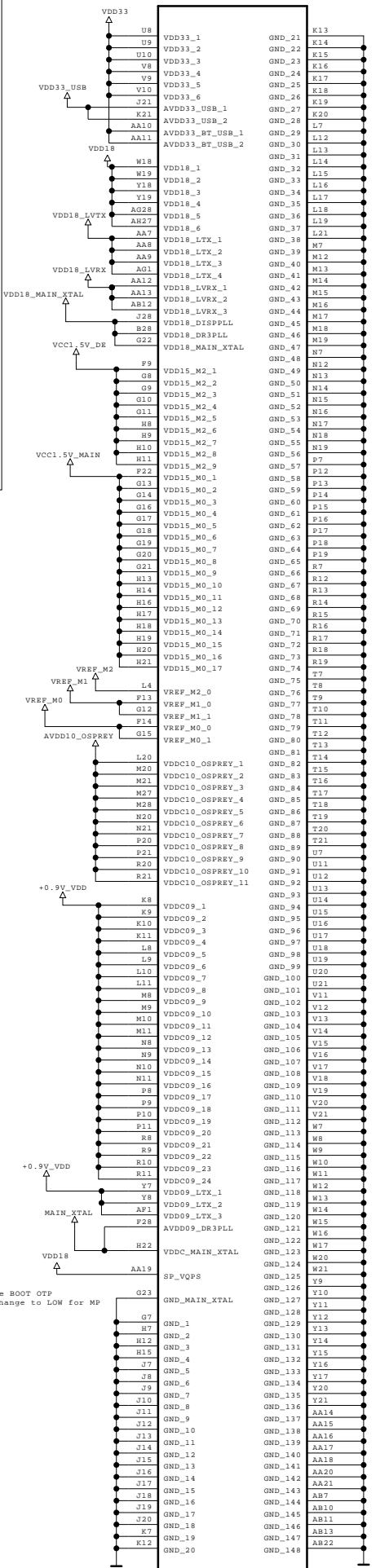

On Package Decap : 0.1uF *3ea

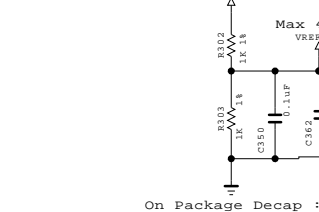
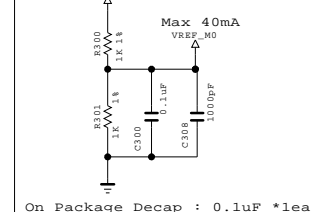

On Package Decap : 0.1uF *1ea

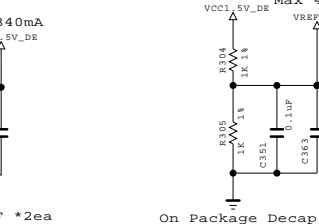
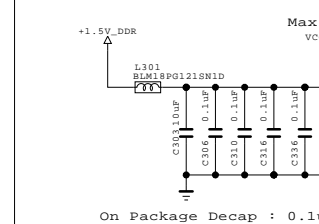

On Package Decap : 0.1uF *2ea

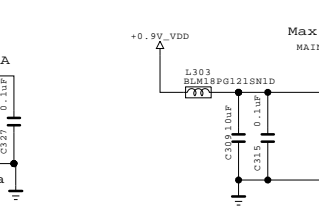
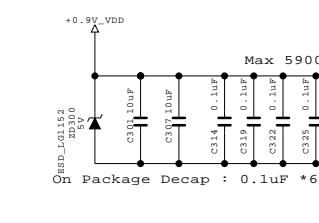

On Package Decap : 0.1uF *6ea

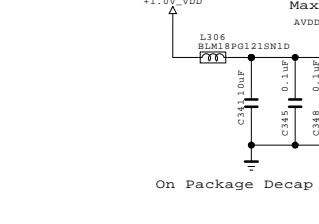
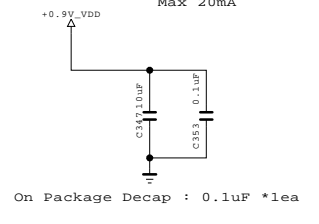

On Package Decap : 0.1uF *3ea

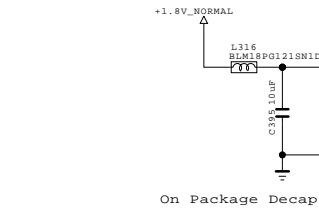
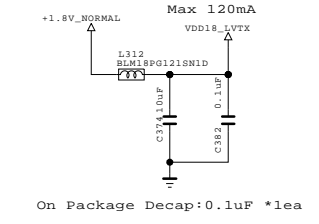

On Package Decap:0.1uF *1ea

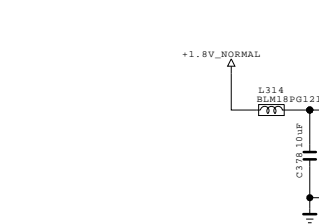
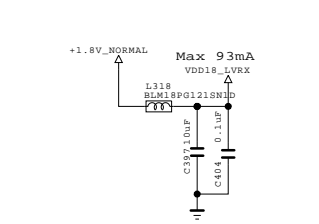

On Package Decap:0.1uF *1ea

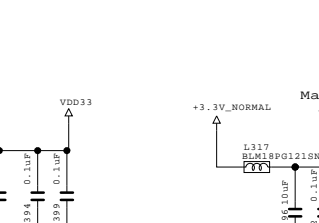
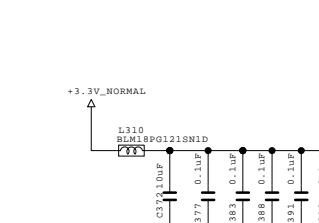

On Package Decap:0.1uF *1ea

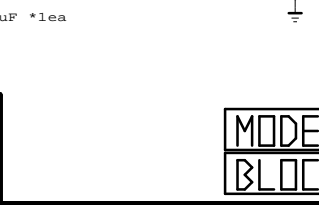
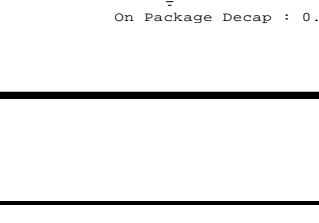

On Package Decap : 0.1uF *1ea

MODEL	LG1152	DATE	
BLOCK	MAIN POWER	SHEET	3

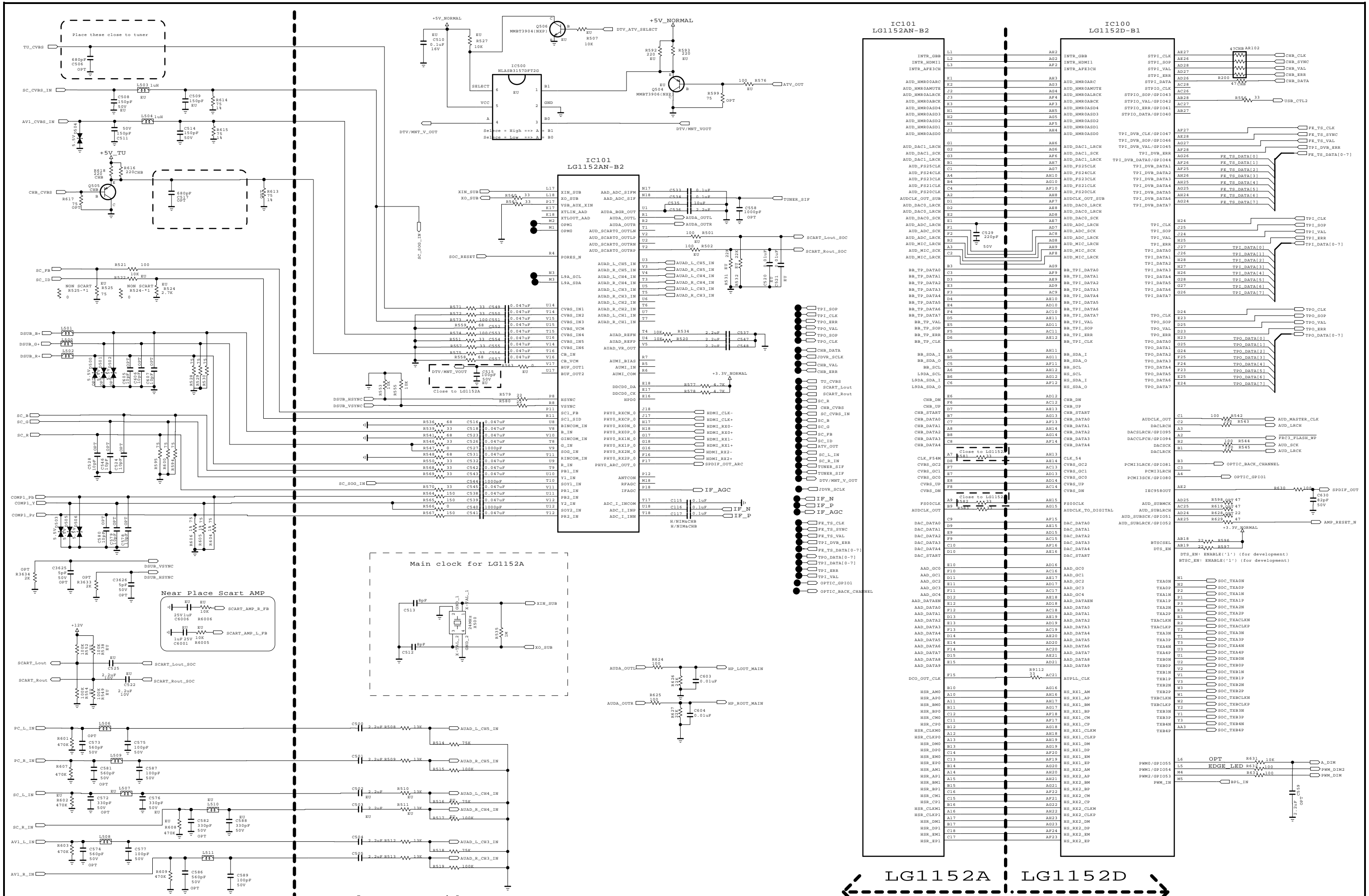

Place JACK Side

THE SYMBOL MARK OF THIS SCHEMATIC DIAGRAM INCORPORATES SPECIAL FEATURES IMPORTANT FOR PROTECTION FROM X-RADIATION. FILRE AND ELECTRICAL SHOCK HAZARDS, WHEN SERVICING IF IS ESSENTIAL THAT ONLY MANUFACTURES SPECIFIED BE USED FOR THE CRITICAL COMPONENTS IN THE SYMBOL MARK OF THE SCHEMATIC.

Place SOC Side

SECRET
LGElectronics

LG ELECTRONICS

MODEL	LG1152 B0	DATE	
BLOCK	MAIN AUDIO/VIDEO	SHEET	3

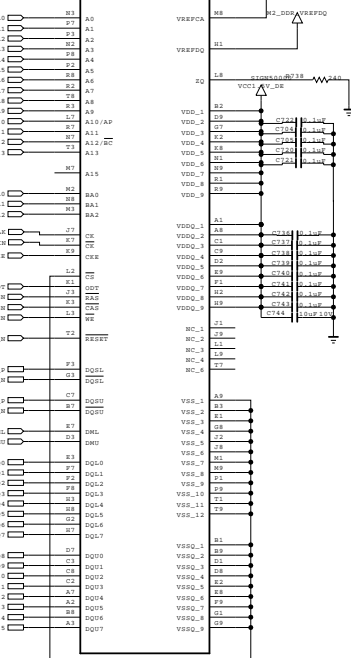
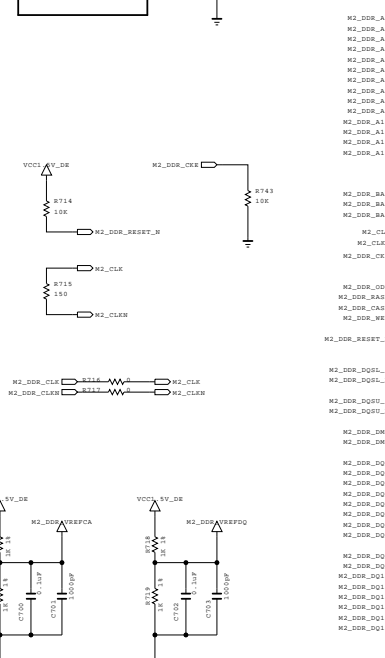
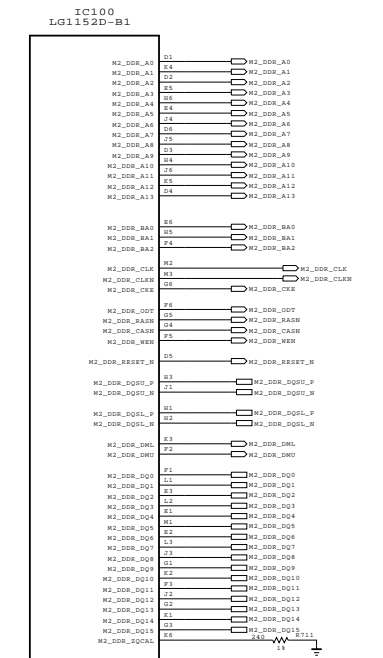
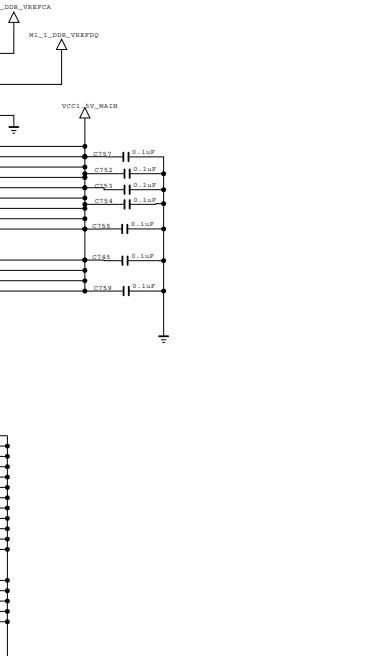
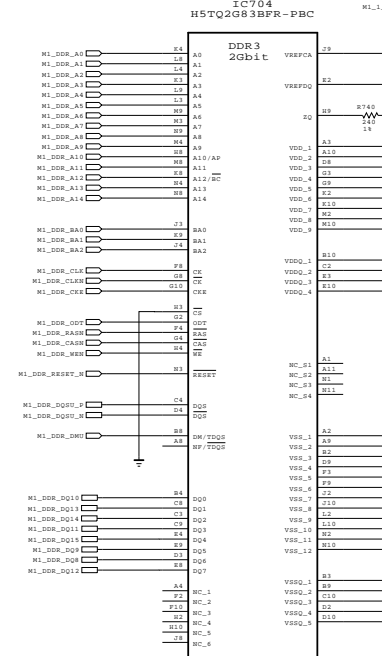
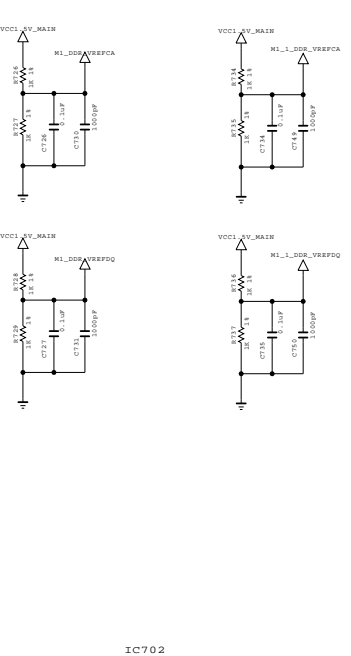
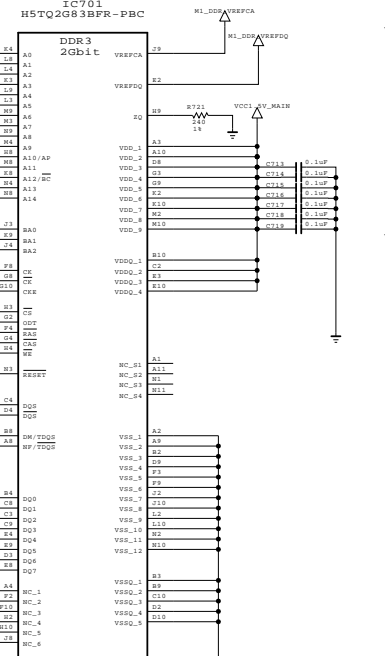
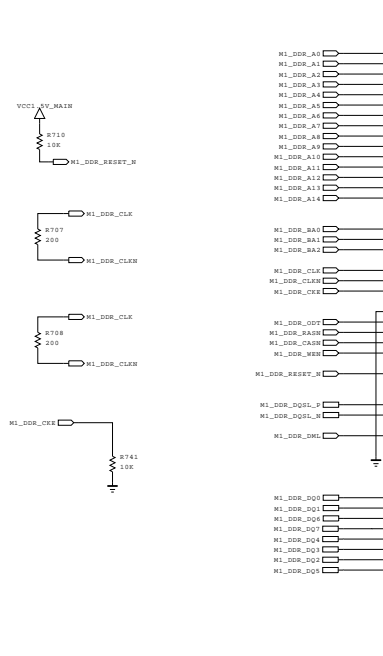
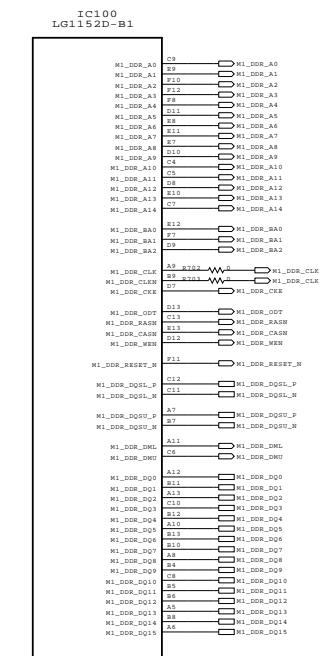
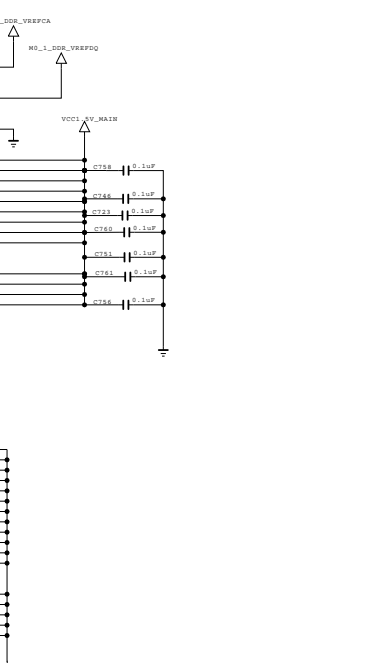
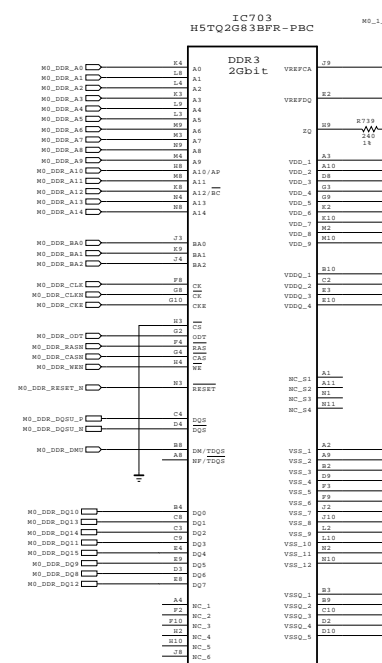
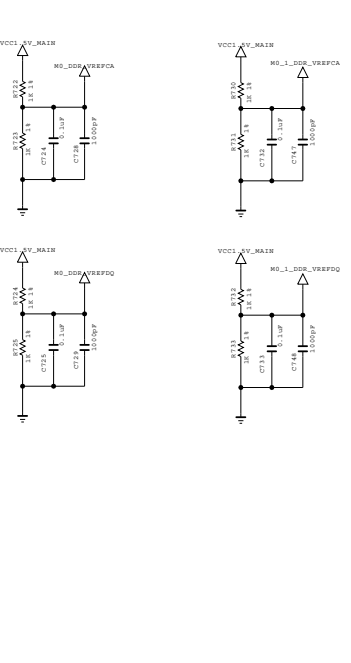
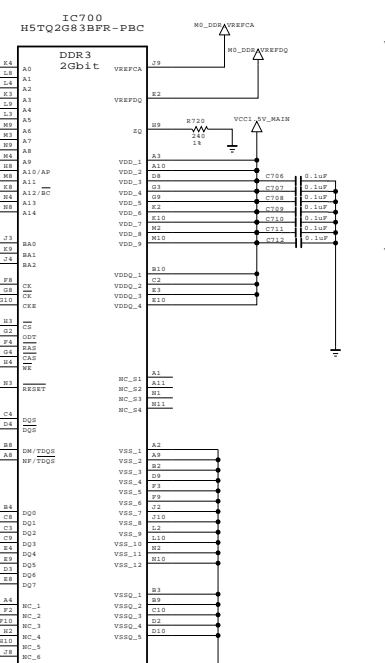
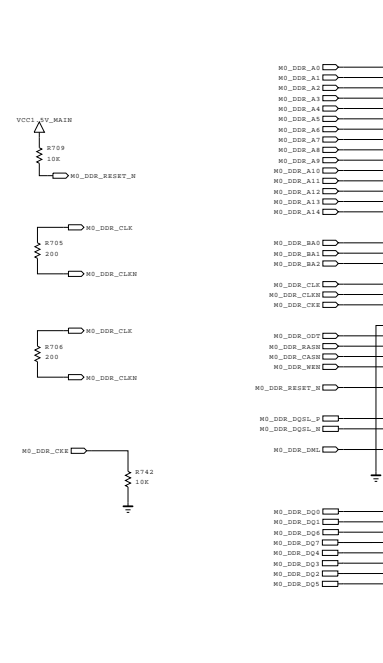
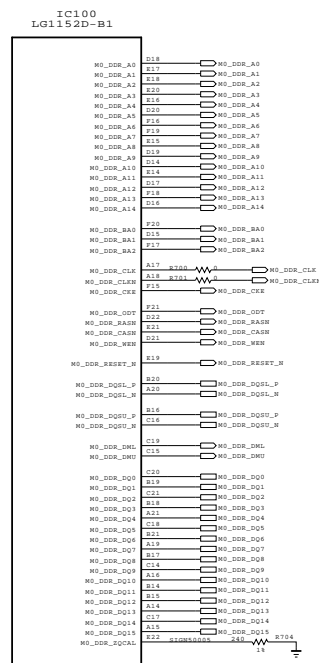

THE SYMBOL MARK OF THIS SCHEMATIC DIAGRAM INCORPORATES SPECIAL FEATURES IMPORTANT FOR PROTECTION FROM X-RADIATION. FILTRATION AND ELECTRICAL SHOCK HAZARDS, WHEN SERVICING IT IS ESSENTIAL THAT ONLY MANUFACTURERS SPECIFIED PARTS BE USED FOR THE CRITICAL COMPONENTS IN THE SYMBOL MARK OF THE SCHEMATIC.

SECRET
LGElectronics

LG ELECTRONICS

MODEL	LG1152 B0	DATE	
BLOCK	MAIN DDR	SHEET	4 / 50

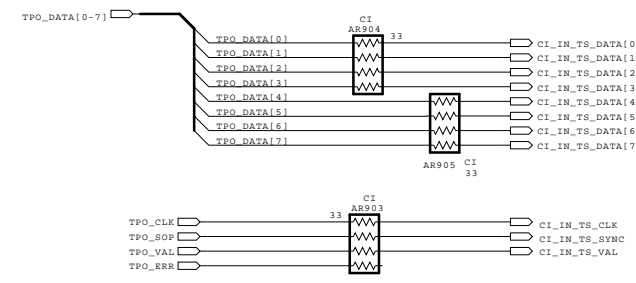
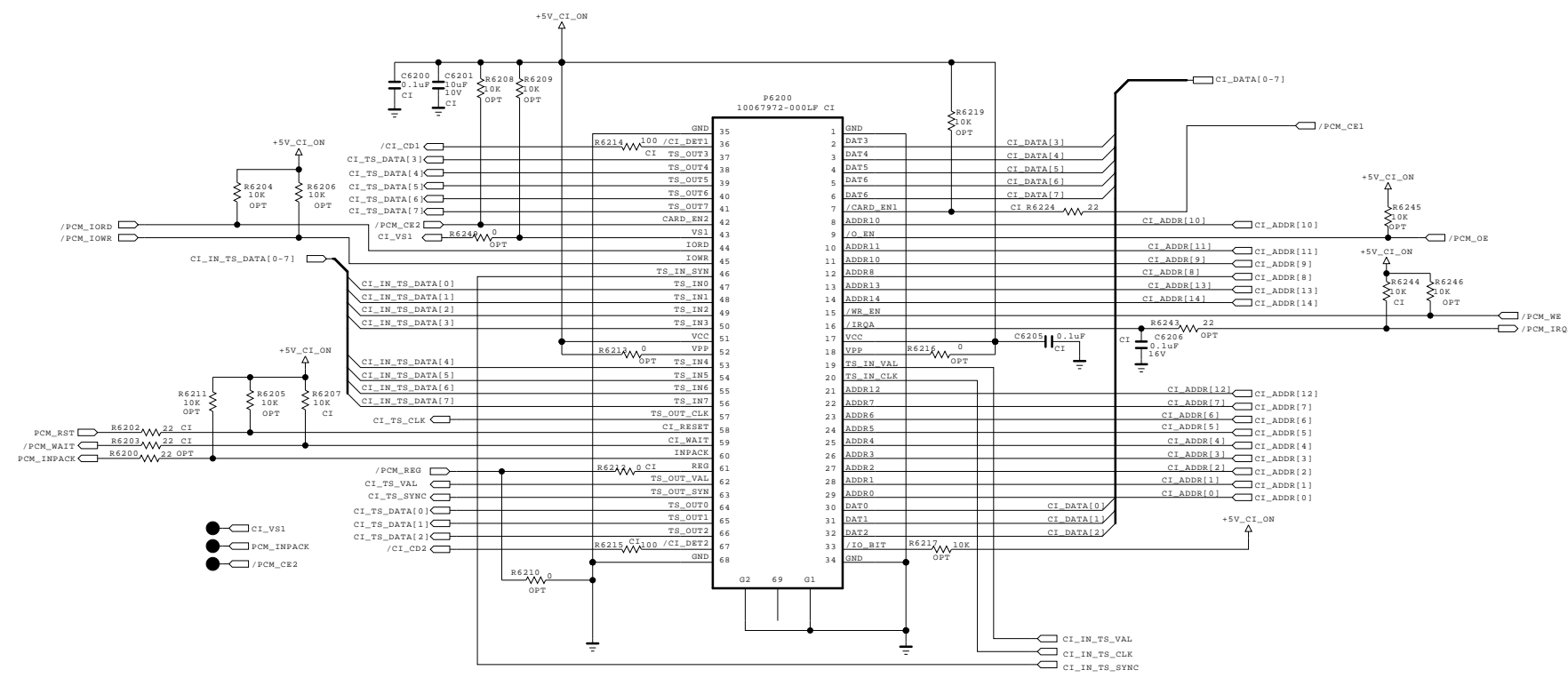

CI HOST I/F

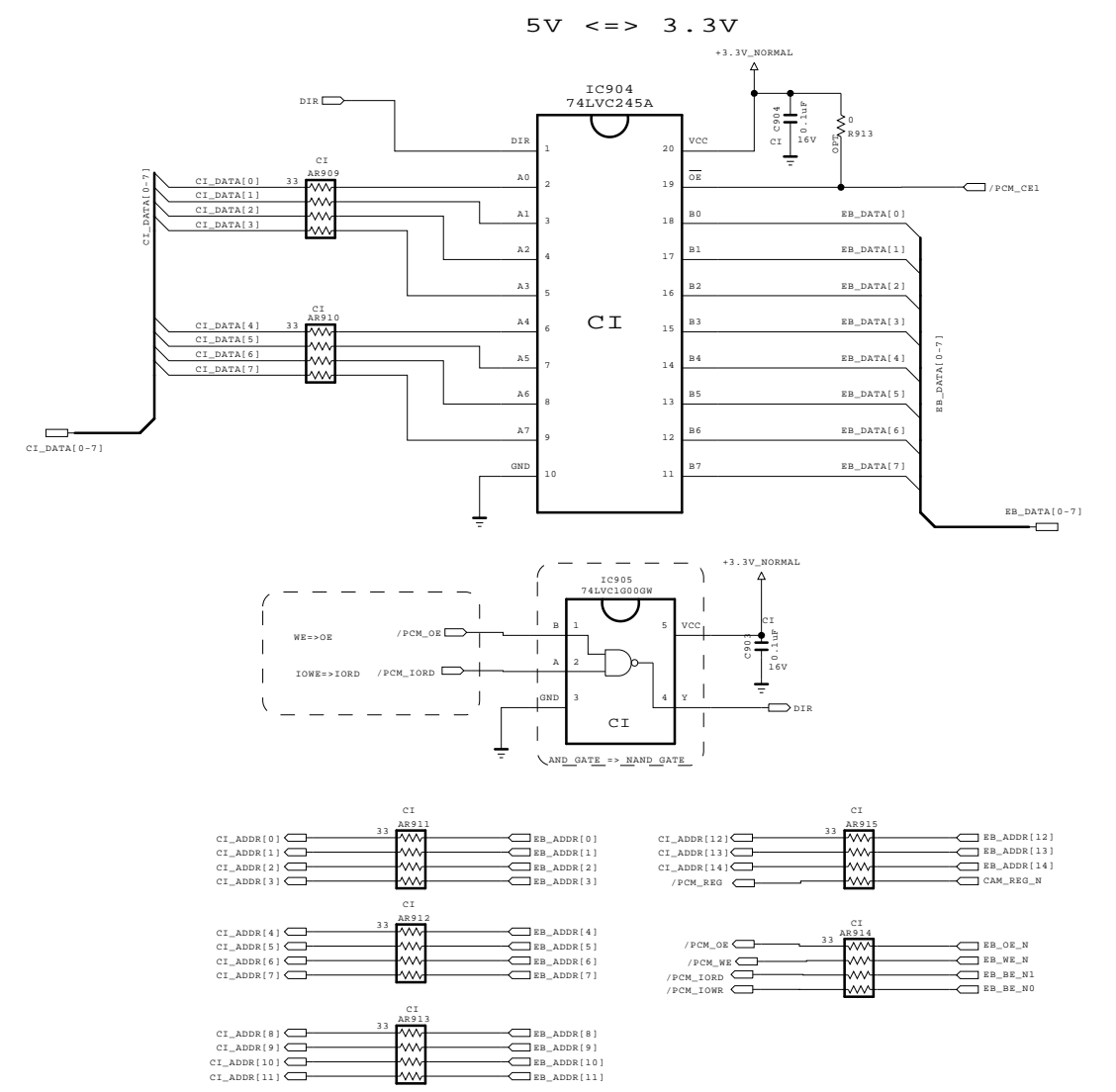

BUFFER FOR 5V => 3.3V

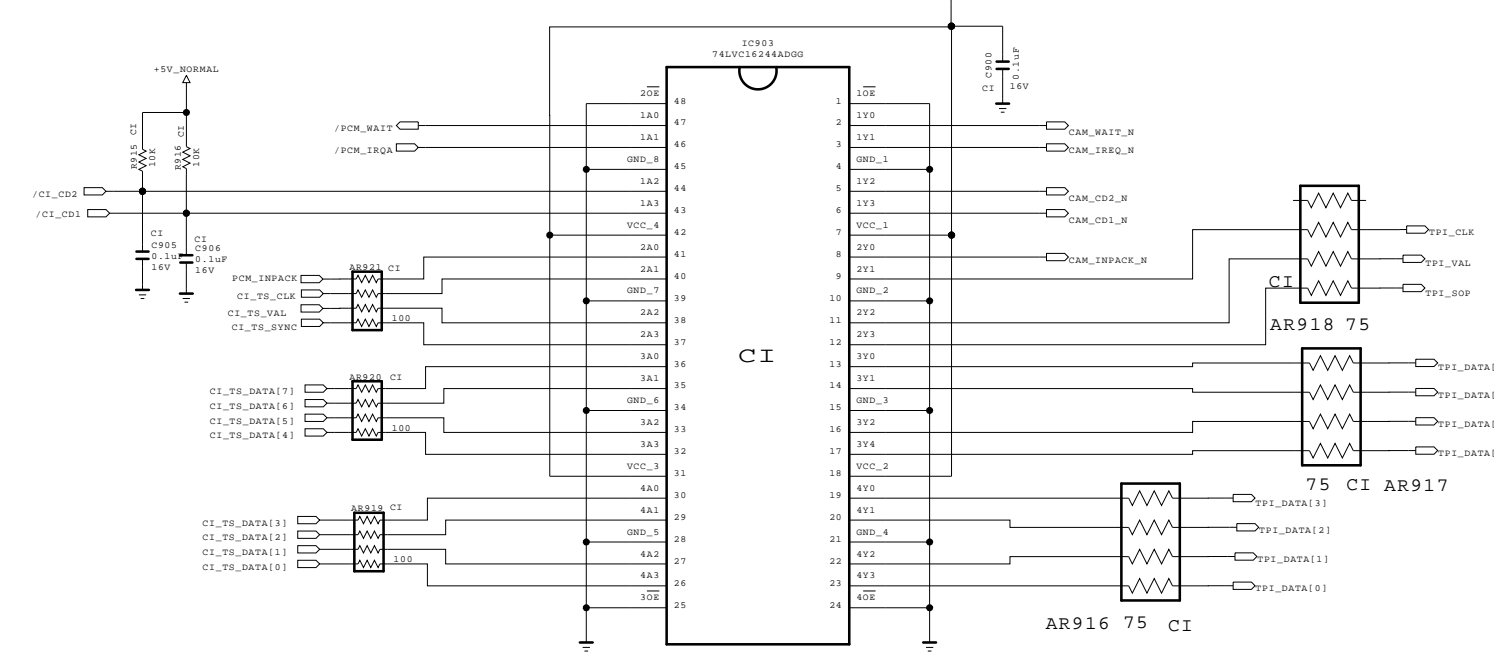

THE SYMBOL MARK OF THIS SCHEMATIC DIAGRAM INCORPORATES SPECIAL FEATURES IMPORTANT FOR PROTECTION FROM X-RADIATION. FILRE AND ELECTRICAL SHOCK HAZARDS, WHEN SERVICING IF IS ESSENTIAL THAT ONLY MANUFACTURERS SPECIFIED PARTS BE USED FOR THE CRITICAL COMPONENTS IN THE SYMBOL MARK OF THE SCHEMATIC.

SECRET
LGElectronics



MODEL		DATE	
BLOCK		SHEET	

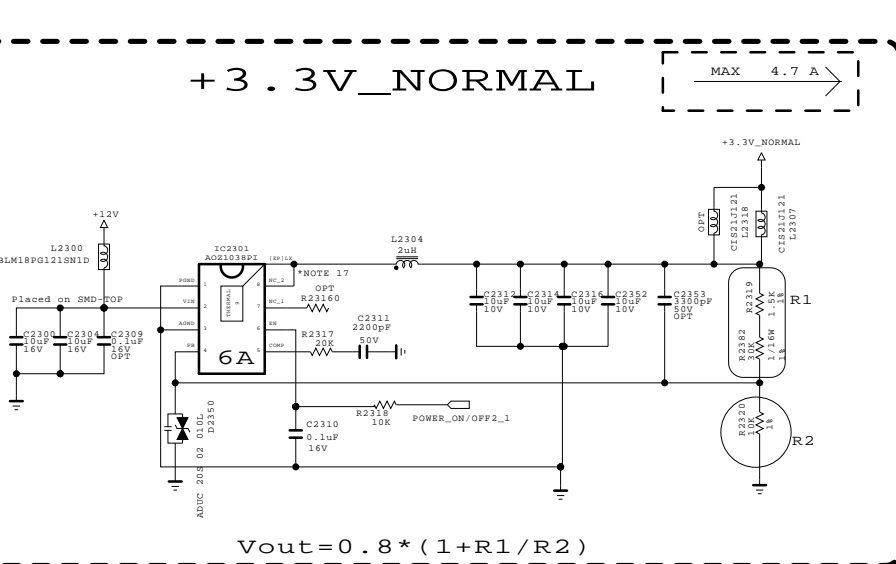
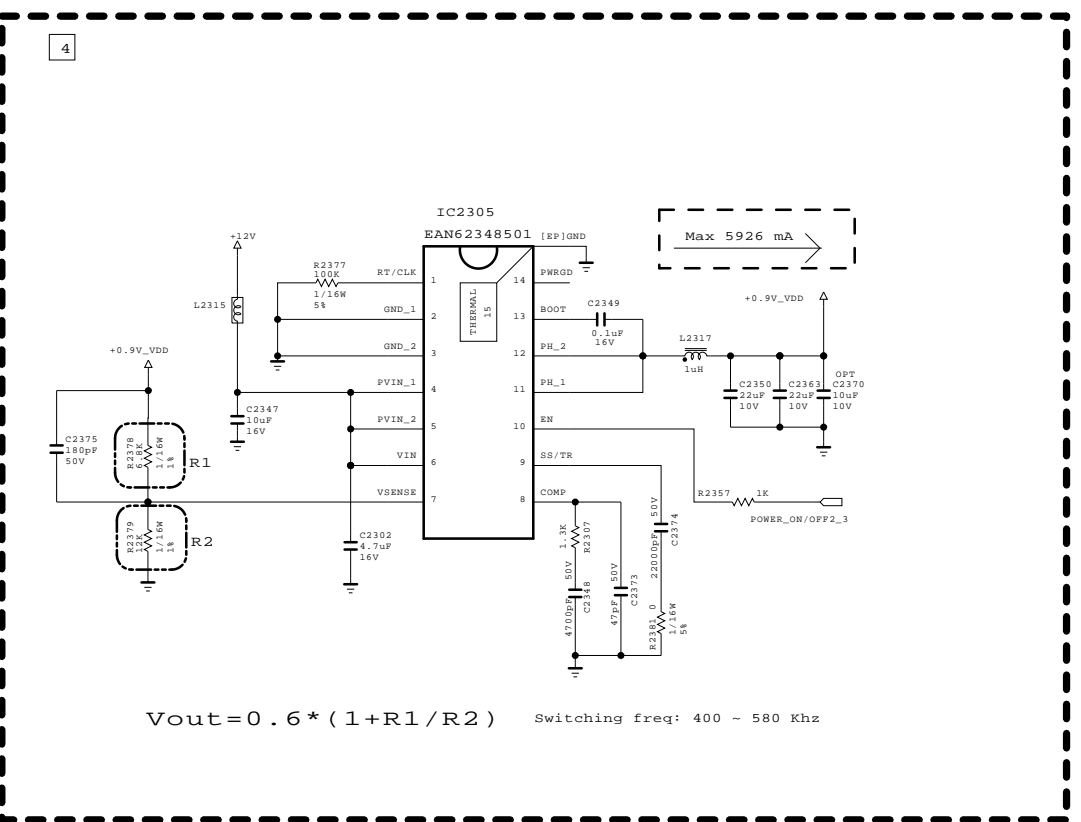
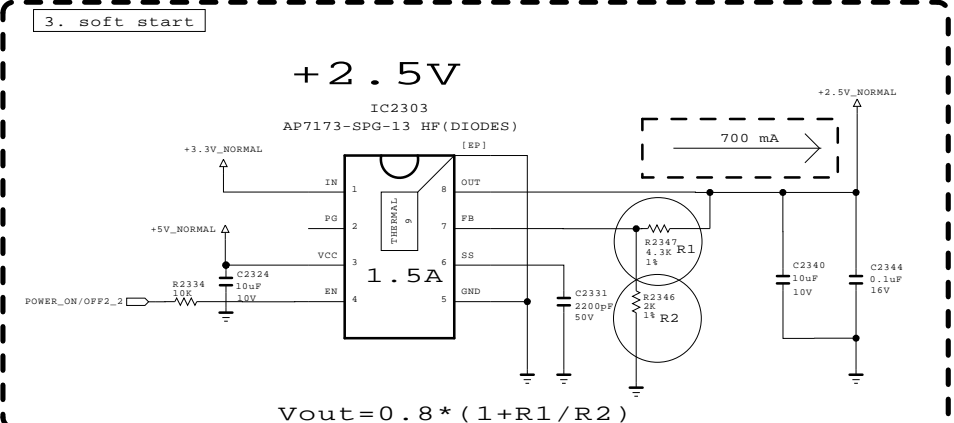
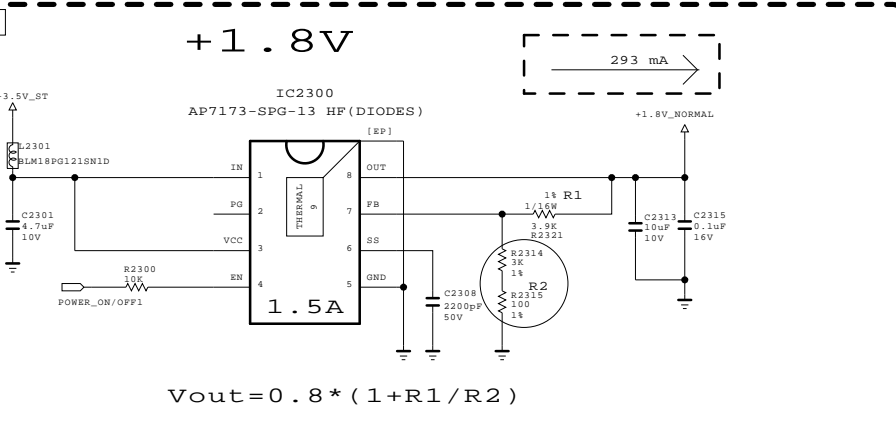
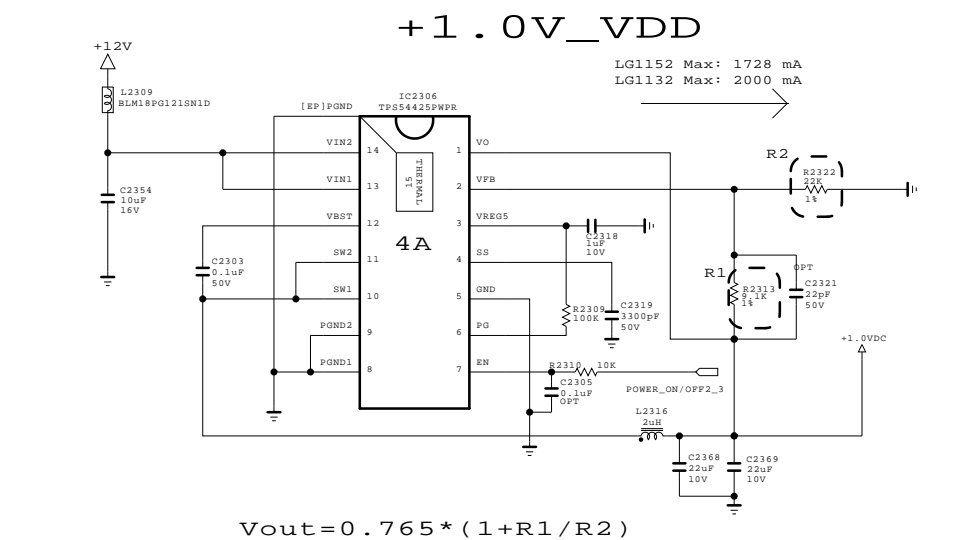
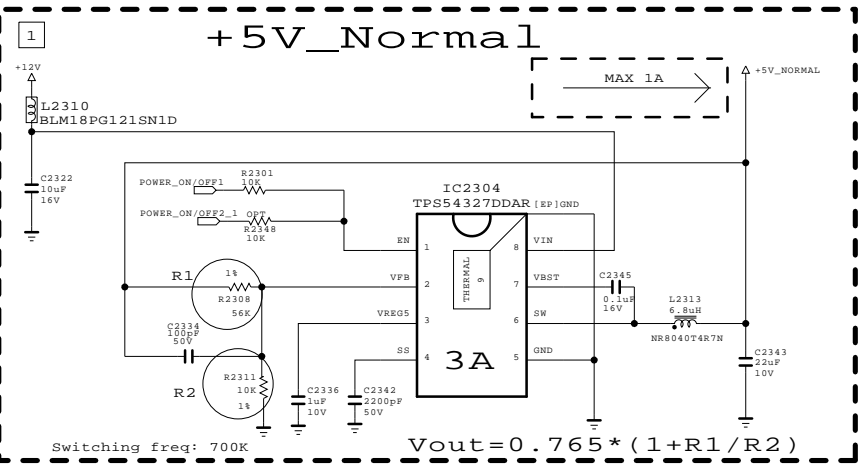
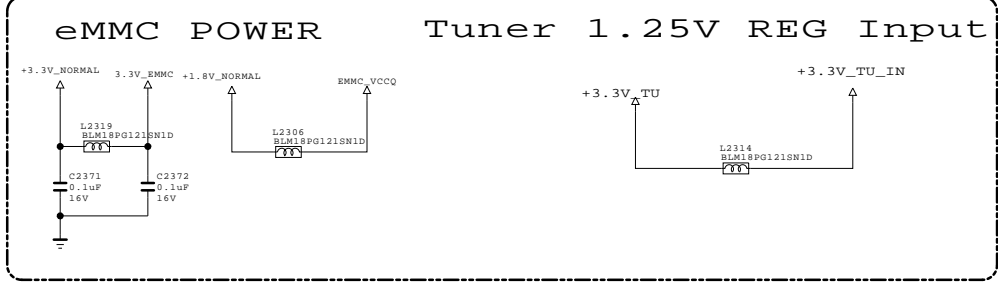
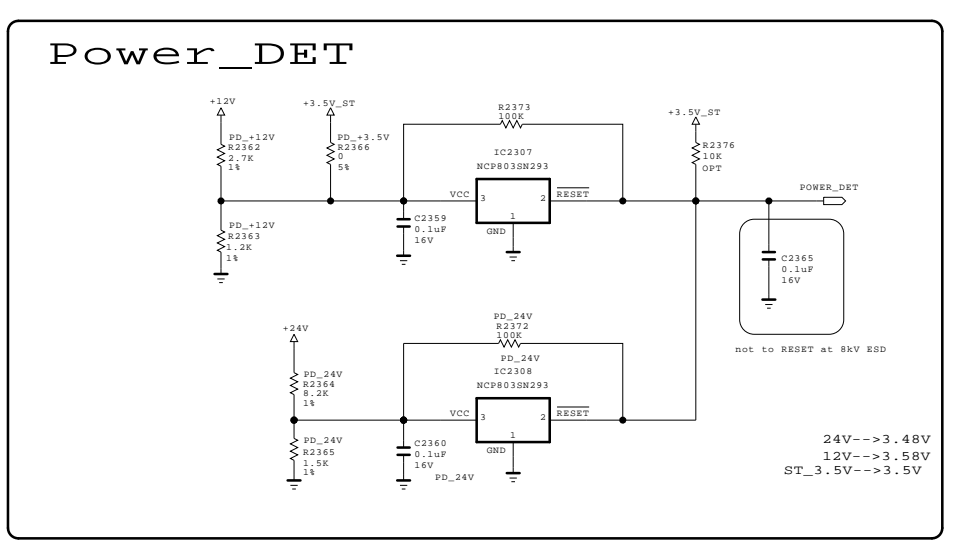
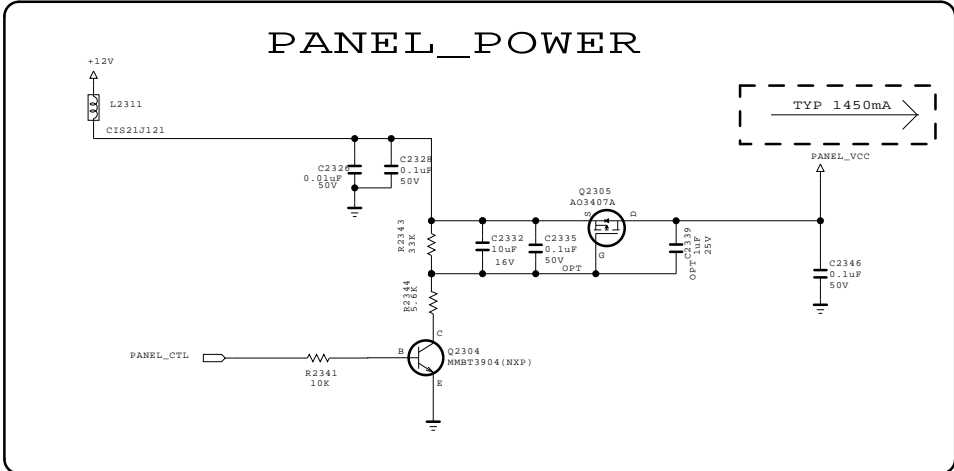
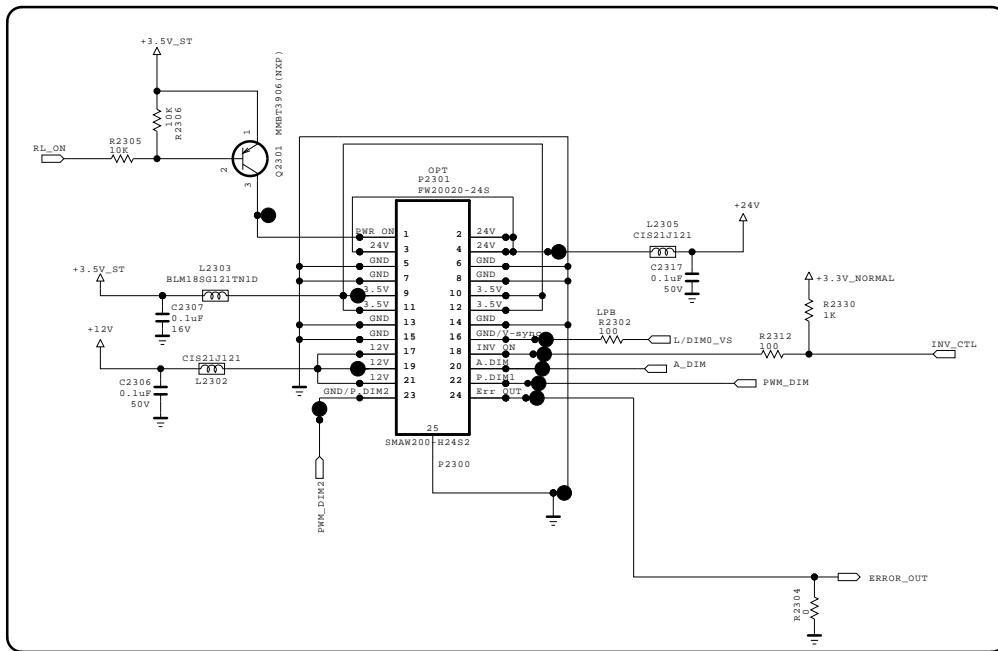

THE Δ SYMBOL MARK OF THIS SCHEMATIC DIAGRAM INCORPORATES SPECIAL FEATURES IMPORTANT FOR PROTECTION FROM X-RADIATION. FILRE AND ELECTRICAL SHOCK HAZARDS, WHEN SERVICING IF IS ESSENTIAL THAT ONLY MANUFACTURERS SPECIFIED PARTS BE USED FOR THE CRITICAL COMPONENTS IN THE Δ SYMBOL MARK OF THE SCHEMATIC.

SECRET
 LGElectronics

LG ELECTRONICS

MODEL	LG1152	DATE	
BLOCK	POWER	SHEET	

Renesas MICOM

For Debug

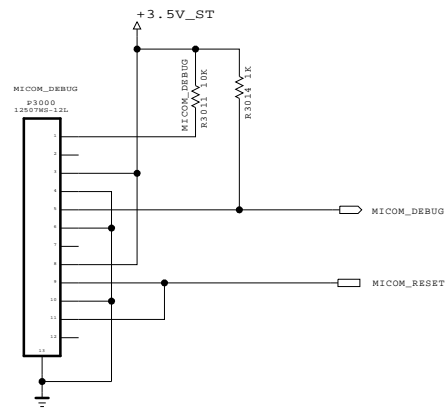

GP4 High/MID Power SEQUENCE

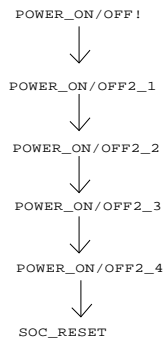

MICOM MODEL OPTION

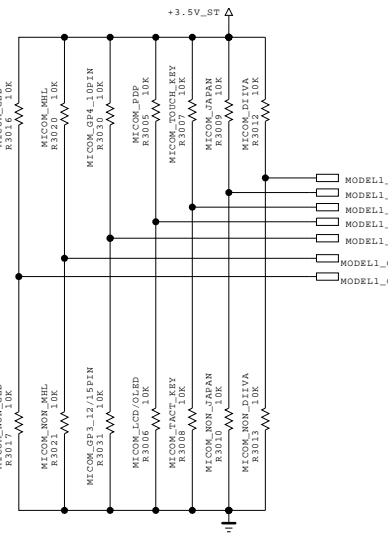

MICOM MODEL OPTION

	0	1	
MODEL_OPT_0	NON DIVA	DIVA	For China
MODEL_OPT_1	NON JAPAN	JAPAN	For JAPAN
MODEL_OPT_2	TACT_KEY	TOUCH_KEY	
MODEL_OPT_3	LCD / OLED	PDP	
MODEL_OPT_4	IR Wafer 12/15Pin GP3_Soft touch)	IR Wafer 10Pin (GP4_TOOL)	For Sample Set
MODEL_OPT_5	NON_MHL	MHL	GP4_HIGH
MODEL_OPT_6	NON_GED	GED	

Eye Sensor Option

	0	1	
MODEL_OPT_4			
MODEL_OPT_2			
0	N/A	MC8101_ABOV (TACT_KEY)	
1	CM3231_CAPELLA (GP3 Soft touch)	CM3231_CAPELLA (GP4 Soft touch)	

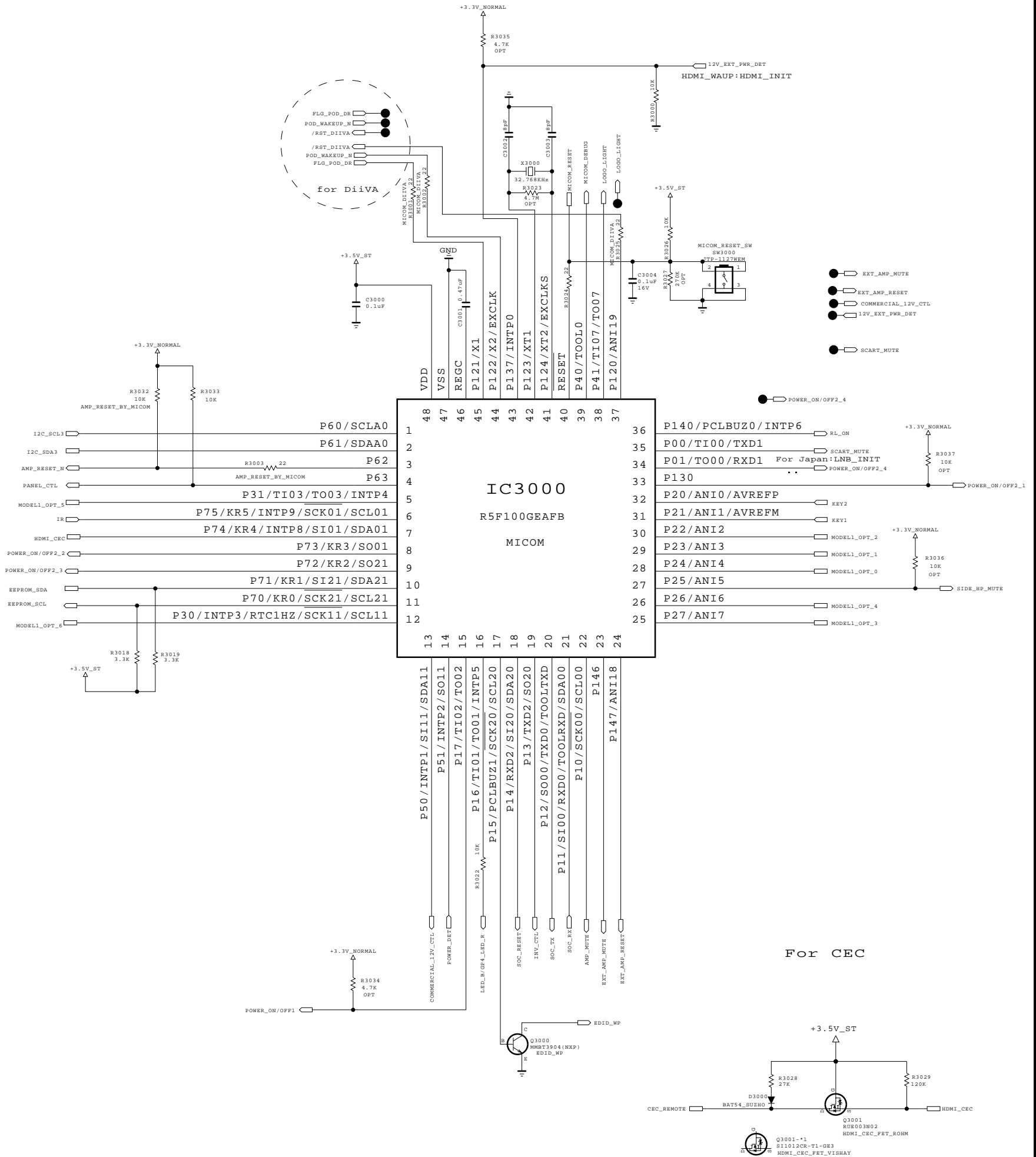

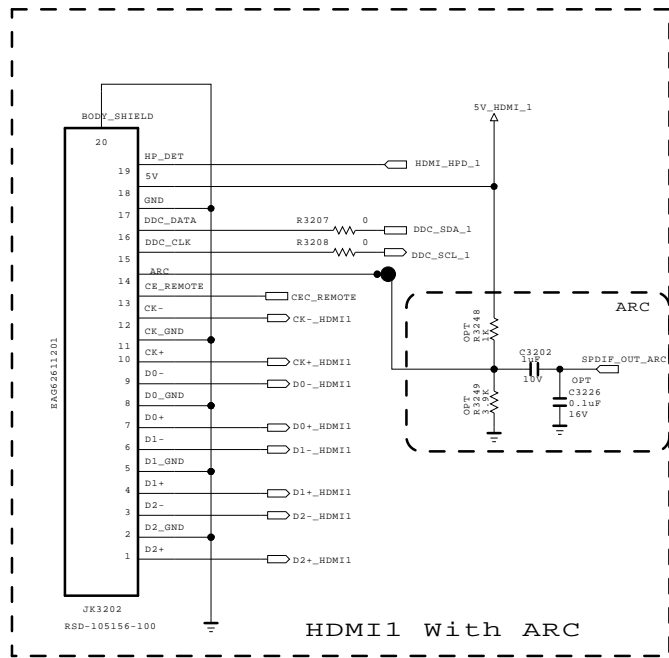

HDMI1 With ARC

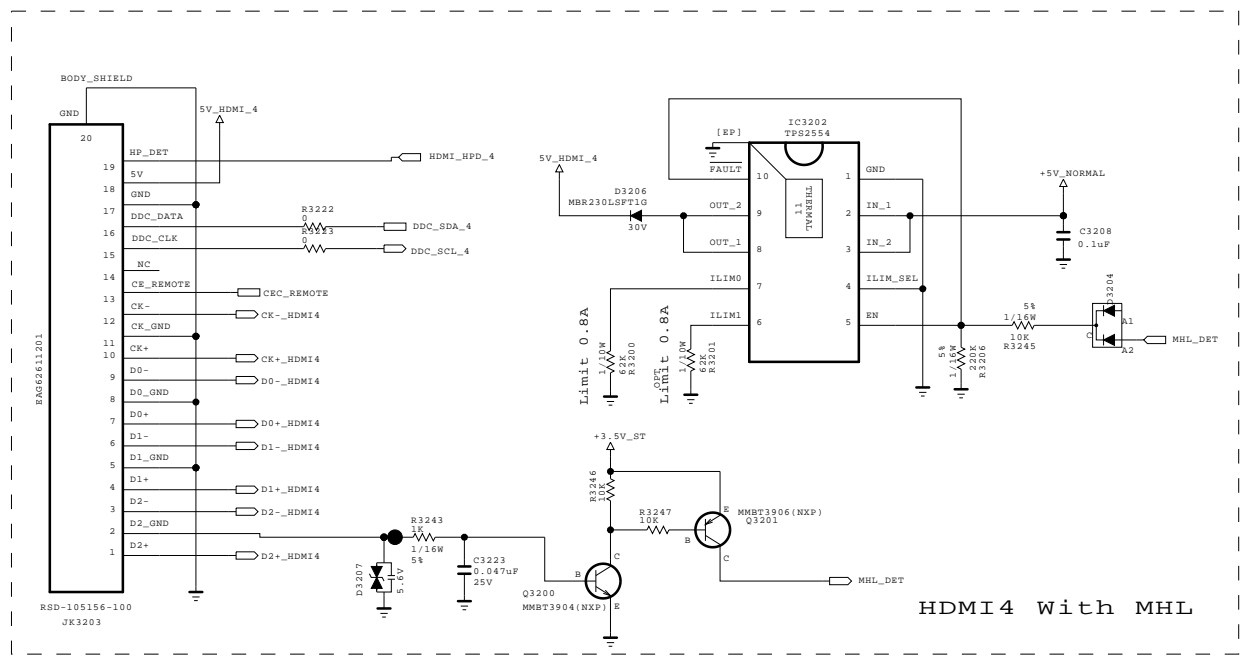

HDMI4 With MHL

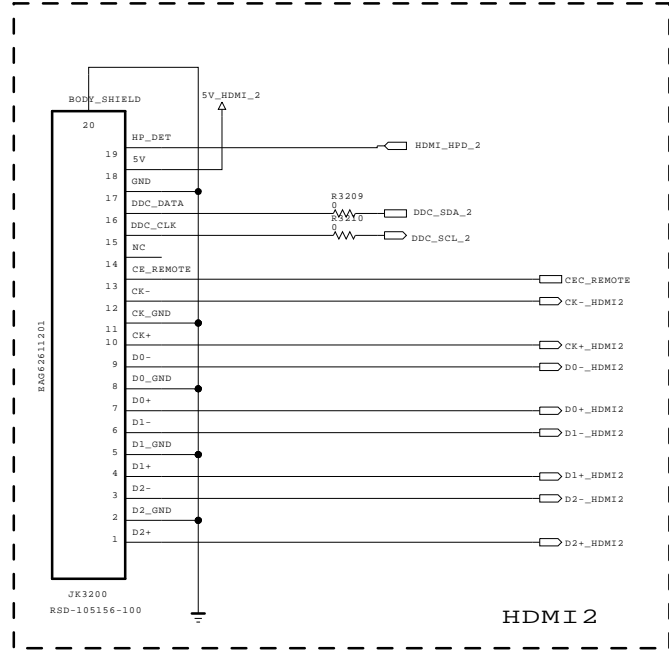
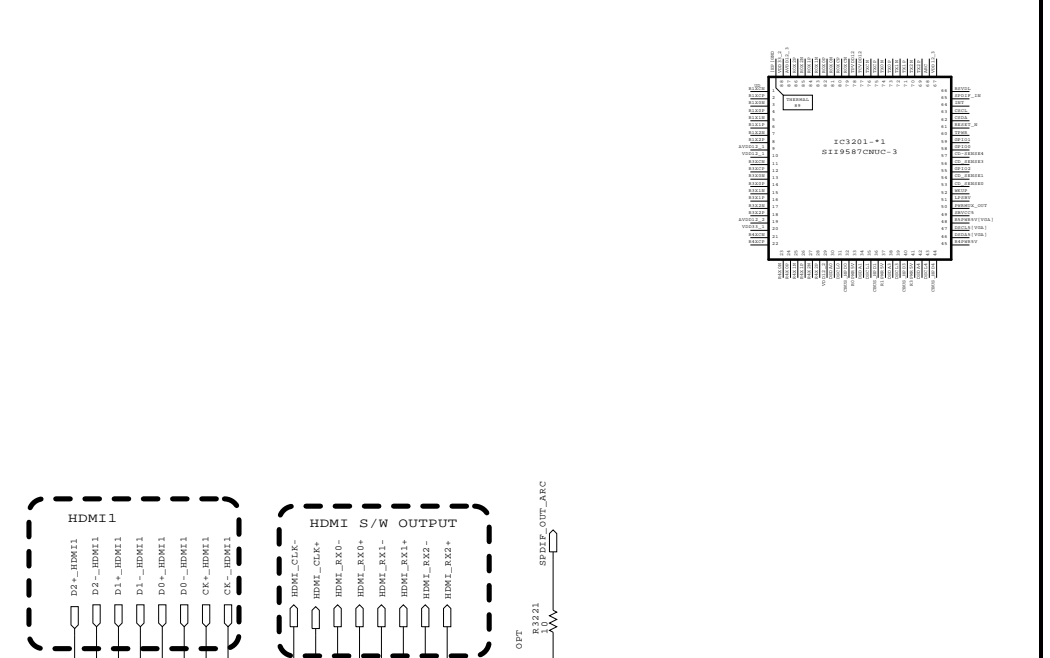

HDMI 2

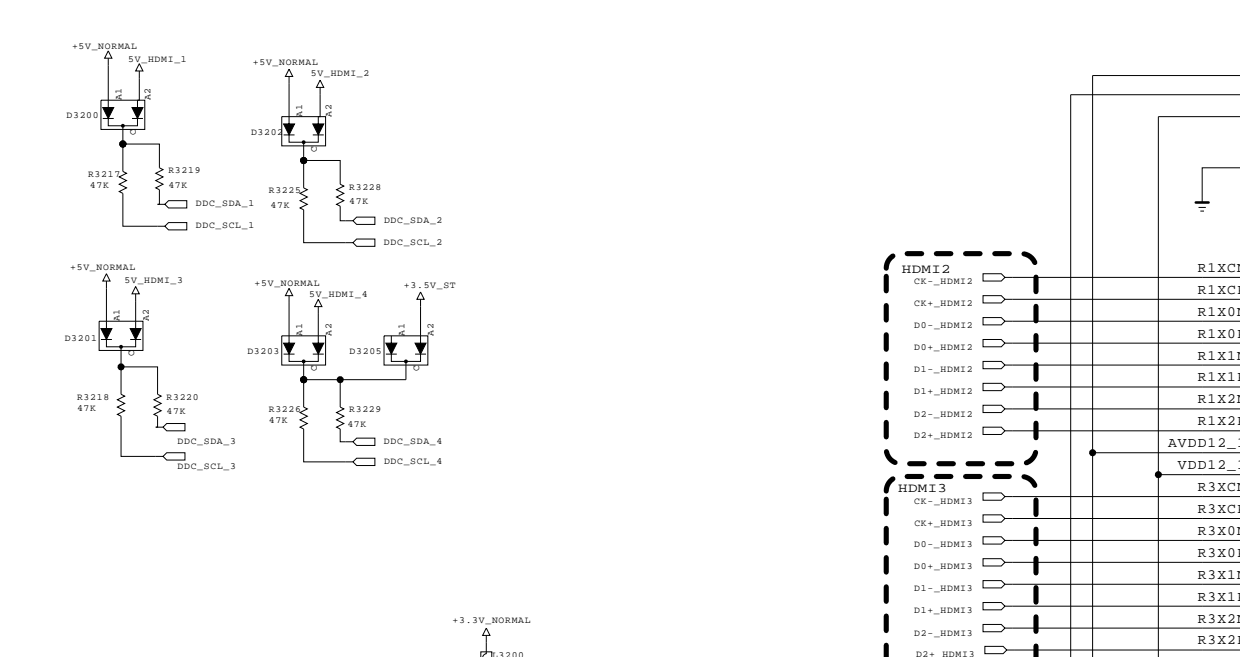

HDMI 3

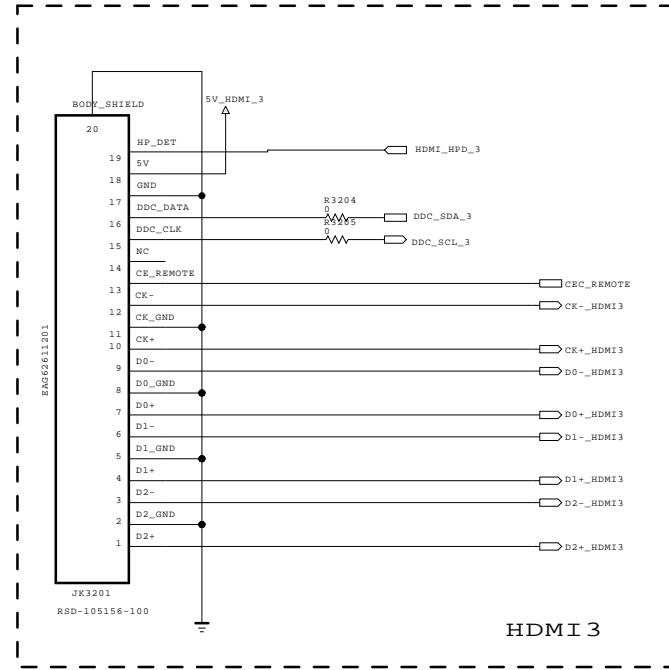

$V_{out} = 0.8 * (1 + R1/R2)$

THE SYMBOL MARK OF THIS SCHEMATIC DIAGRAM INCORPORATES SPECIAL FEATURES IMPORTANT FOR PROTECTION FROM X-RADIATION. FILRE AND ELECTRICAL SHOCK HAZARDS, WHEN SERVICING IF IS ESSENTIAL THAT ONLY MANUFACTURES SPECIFIED PARTS BE USED FOR THE CRITICAL COMPONENTS IN THE SYMBOL MARK OF THE SCHEMATIC.

SECRET
LGElectronics



MODEL	GP4	DATE	2011.10.19
BLOCK	HDMI	SHEET	32

RGB / PC AUDIO / SPDIF

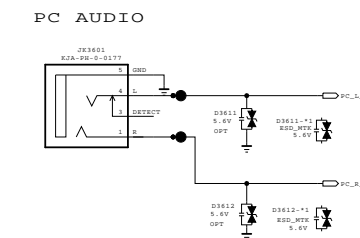
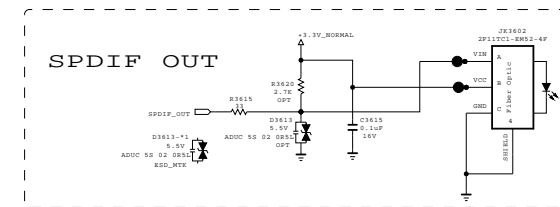
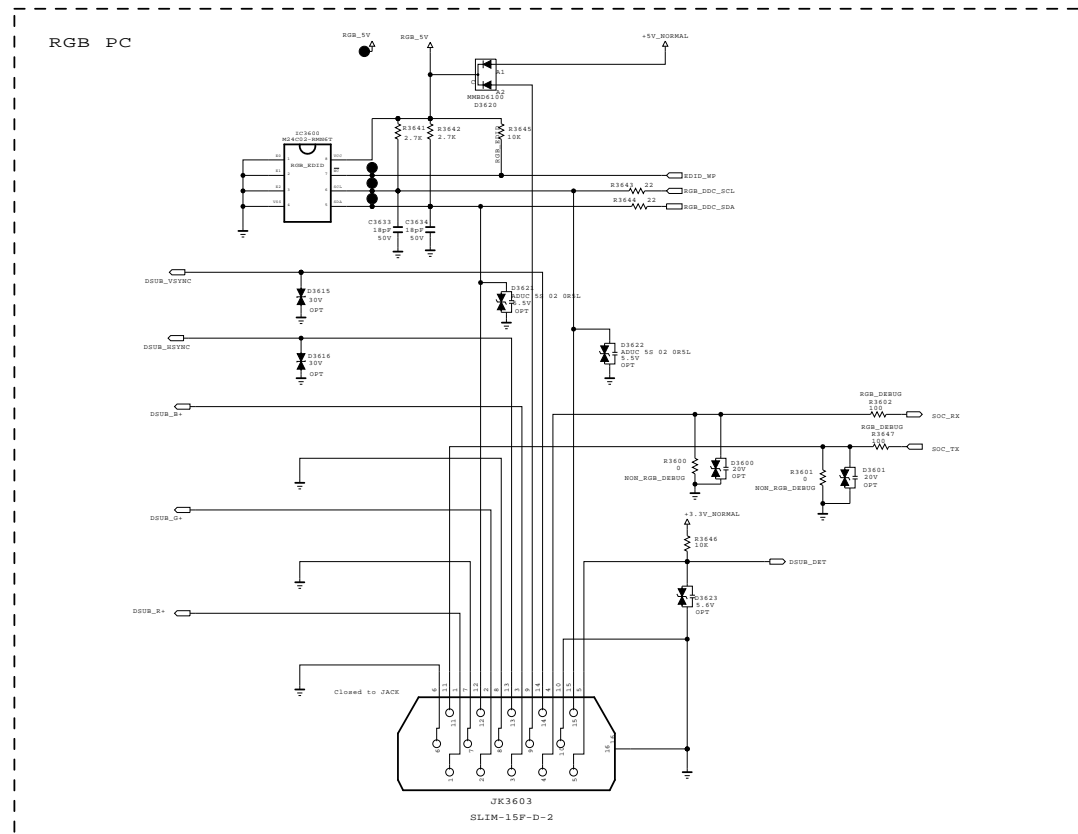

THE SYMBOL MARK OF THIS SCHEMATIC DIAGRAM INCORPORATES SPECIAL FEATURES IMPORTANT FOR PROTECTION FROM X-RADIATION. FILRE AND ELECTRICAL SHOCK HAZARDS, WHEN SERVICING IF IS ESSENTIAL THAT ONLY MANUFACTURES SPECIFIED PARTS BE USED FOR THE CRITICAL COMPONENTS IN THE SYMBOL MARK OF THE SCHEMATIC.

SECRET
LGElectronics

LG ELECTRONICS

MODEL	JACK HIGH / MID	DATE	2011.11.21
BLOCK		SHEET	36 /

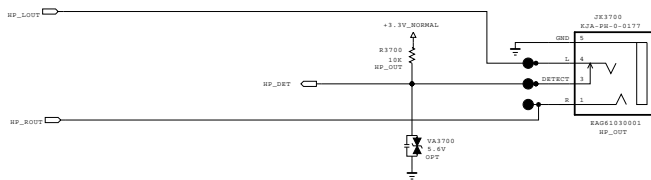

ESD for MTK

VA3700-1
5.1V
ESD_MTK_WP_DET

ESD for LG1152

VA3700-2
5.1V
ESD_LG1152_WP_DET

THE SYMBOL MARK OF THIS SCHEMATIC DIAGRAM INCORPORATES SPECIAL FEATURES IMPORTANT FOR PROTECTION FROM X-RADIATION. FILRE AND ELECTRICAL SHOCK HAZARDS, WHEN SERVICING IF IS ESSENTIAL THAT ONLY MANUFACTURES SPECIFIED PARTS BE USED FOR THE CRITICAL COMPONENTS IN THE SYMBOL MARK OF THE SCHEMATIC.

SECRET
LGElectronics

LG ELECTRONICS

MODEL	JACK_COMMON	DATE	2011.11.21
BLOCK		SHEET	37 /

RS232C

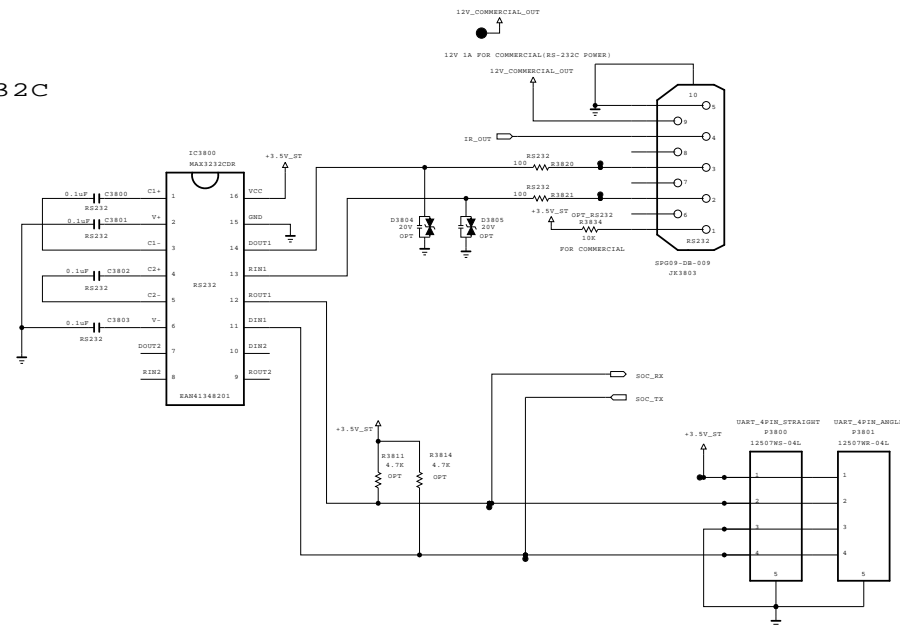

CVBS 1 PHONE JACK

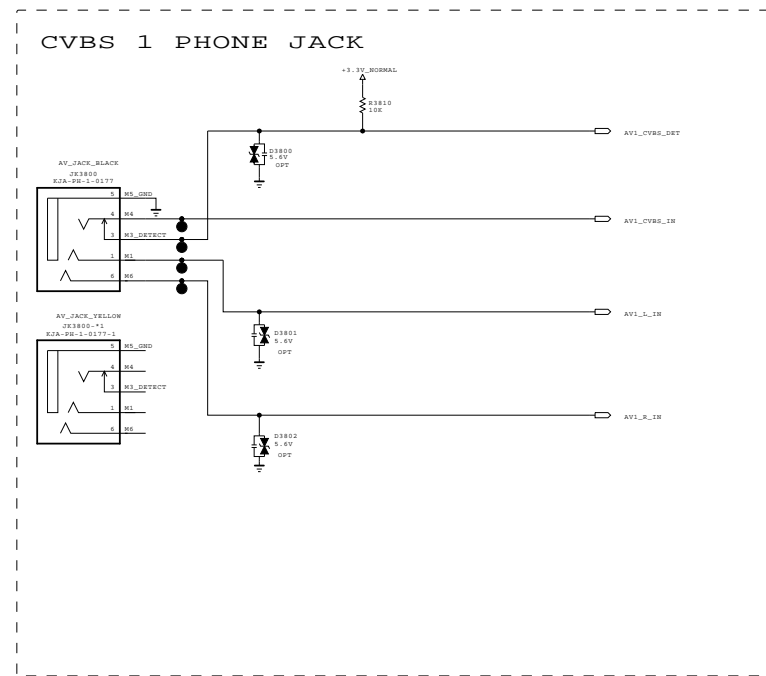

COMPONENT 1 PHONE JACK

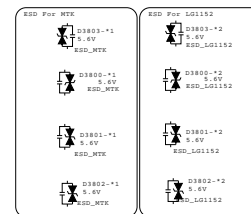
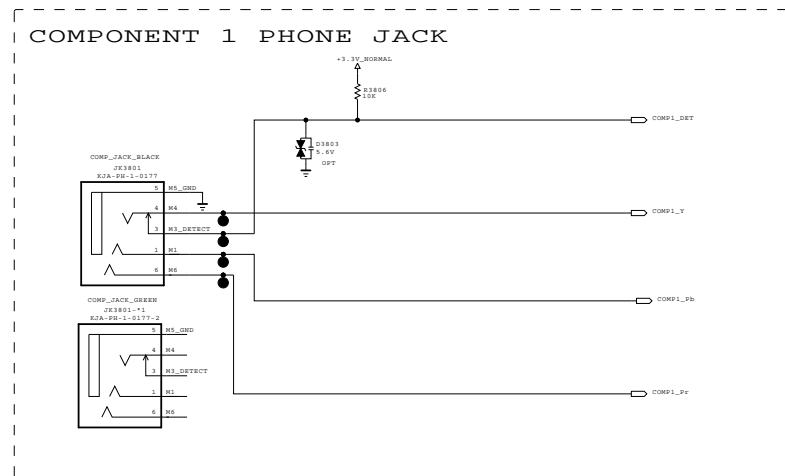

THE SYMBOL MARK OF THIS SCHEMATIC DIAGRAM INCORPORATES SPECIAL FEATURES IMPORTANT FOR PROTECTION FROM X-RADIATION, FILRE AND ELECTRICAL SHOCK HAZARDS, WHEN SERVICING IF IS ESSENTIAL THAT ONLY MANUFACTURES SPECIFIED PARTS BE USED FOR THE CRITICAL COMPONENTS IN THE SYMBOL MARK OF THE SCHEMATIC.

SECRET
LGElectronics



MODEL	JACK_COMMON	DATE	2011.11.21
BLOCK		SHEET	38 /

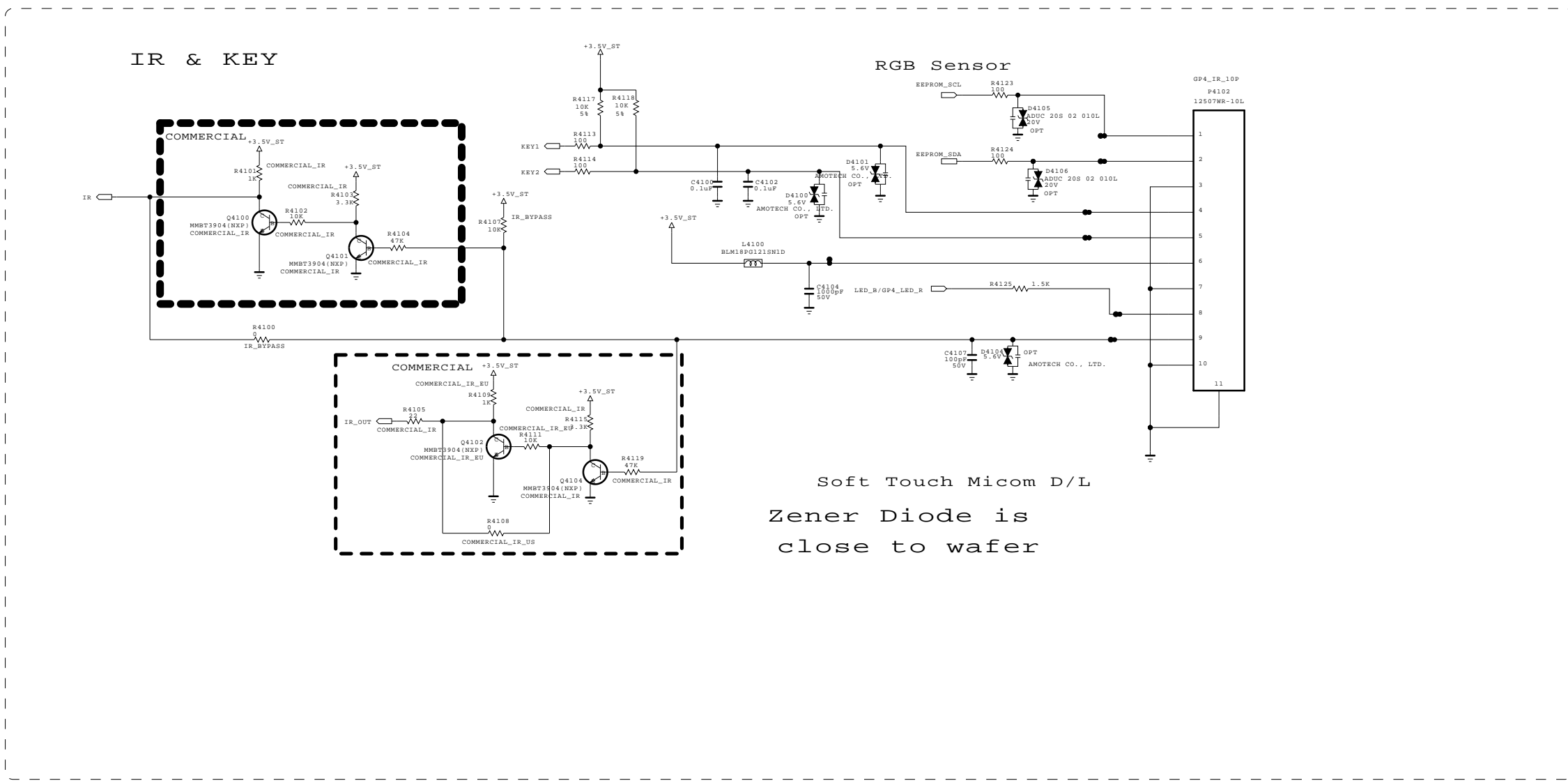

ESD for MTK

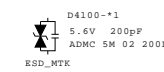

ESD for LG1152

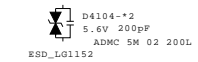
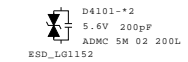
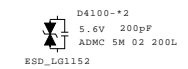

THE SYMBOL MARK OF THIS SCHEMATIC DIAGRAM INCORPORATES SPECIAL FEATURES IMPORTANT FOR PROTECTION FROM X-RADIATION. FILRE AND ELECTRICAL SHOCK HAZARDS, WHEN SERVICING IF IS ESSENTIAL THAT ONLY MANUFACTURES SPECIFIED PARTS BE USED FOR THE CRITICAL COMPONENTS IN THE SYMBOL MARK OF THE SCHEMATIC.

SECRET
LGElectronics



MODEL	IR / KEY	DATE	2011.11.21
BLOCK		SHEET	41 /

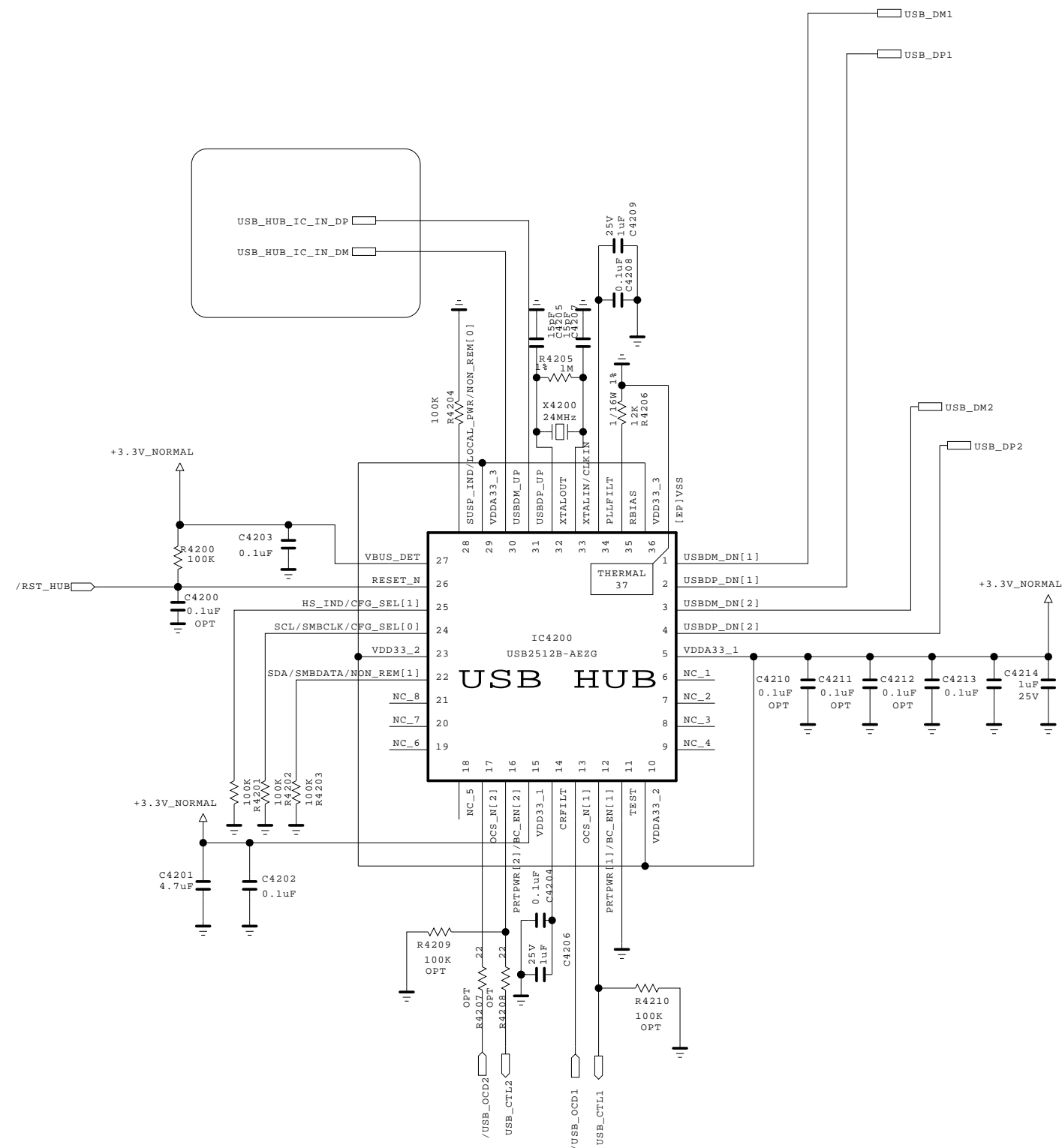

THE SYMBOL MARK OF THIS SCHEMATIC DIAGRAM INCORPORATES SPECIAL FEATURES IMPORTANT FOR PROTECTION FROM X-RADIATION. FILRE AND ELECTRICAL SHOCK HAZARDS, WHEN SERVICING IF IS ESSENTIAL THAT ONLY MANUFACTURES SPECIFIED PARTS BE USED FOR THE CRITICAL COMPONENTS IN THE SYMBOL MARK OF THE SCHEMATIC.

SECRET
LGElectronics

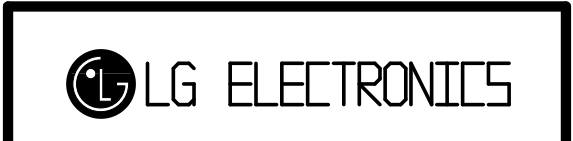

MODEL	USB3_HUB	DATE	2011.06.13
BLOCK		SHEET	42 /

+5V_USB FOR USB1

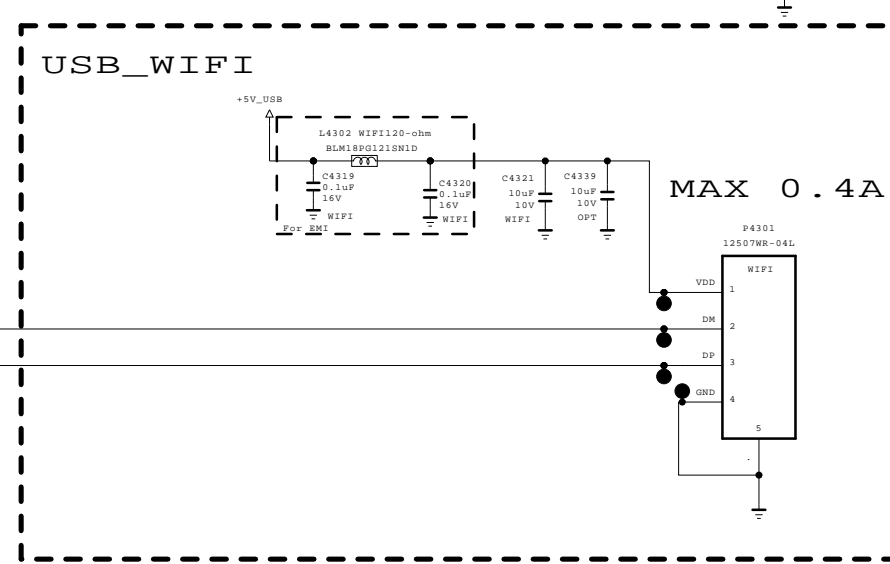
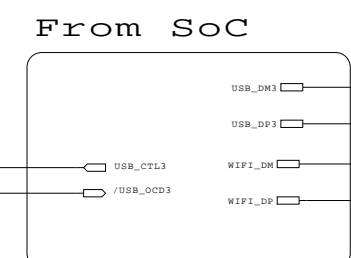
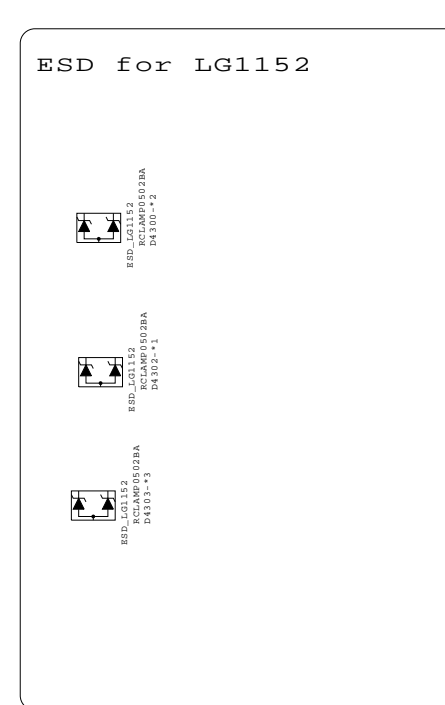
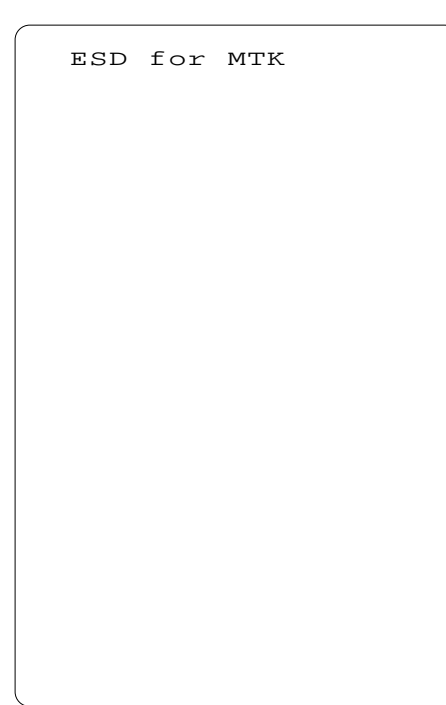
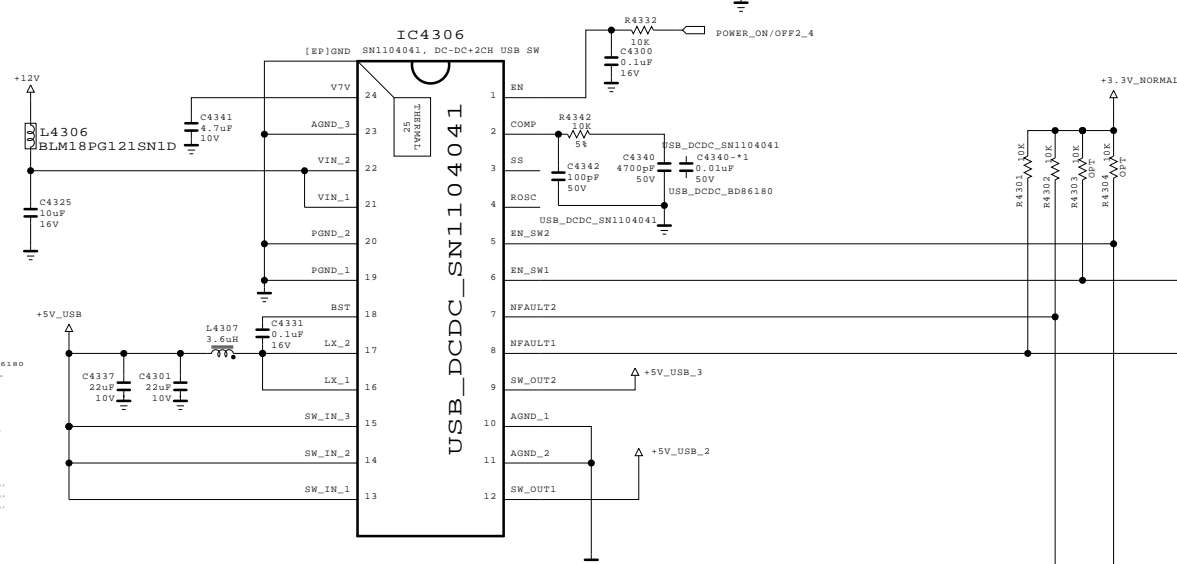
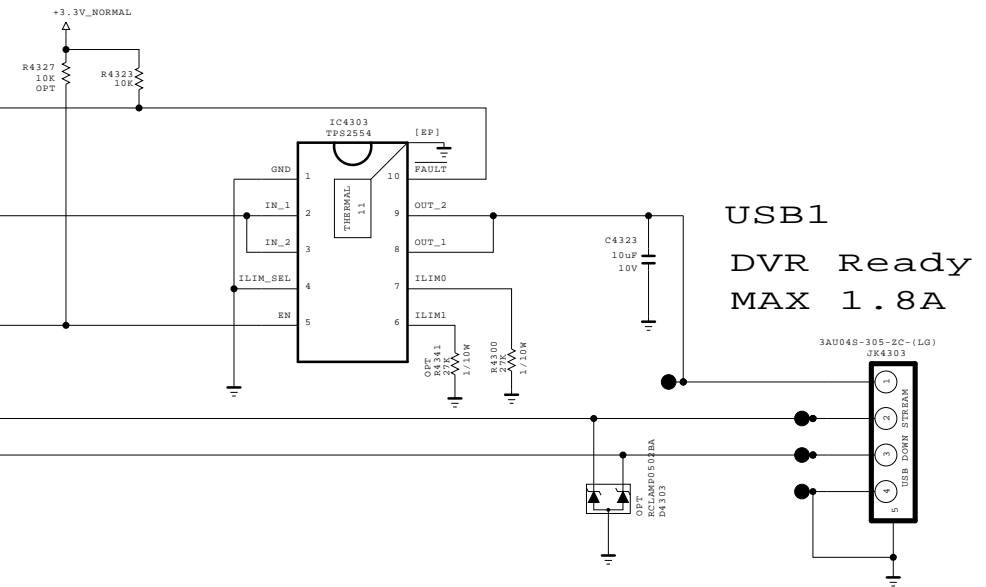
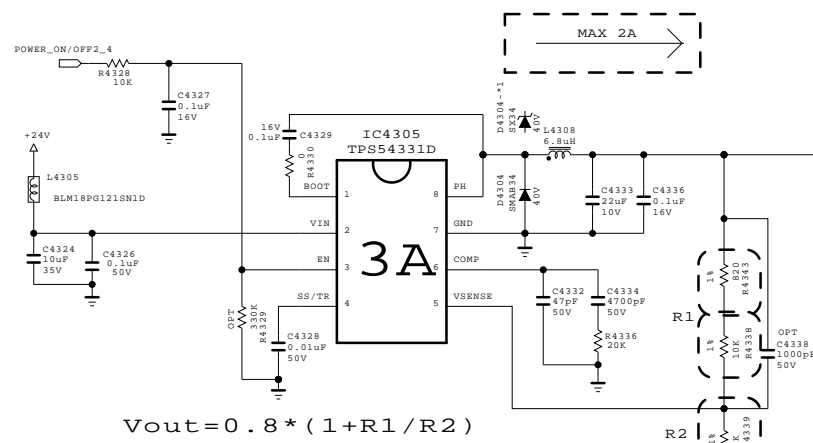

THE SYMBOL MARK OF THIS SCHEMATIC DIAGRAM INCORPORATES SPECIAL FEATURES IMPORTANT FOR PROTECTION FROM X-RADIATION. FILRE AND ELECTRICAL SHOCK HAZARDS, WHEN SERVICING IF IS ESSENTIAL THAT ONLY MANUFACTURES SPECIFIED PARTS BE USED FOR THE CRITICAL COMPONENTS IN THE SYMBOL MARK OF THE SCHEMATIC.

SECRET
LGElectronics



MODEL	USB3_HUB_WiFi	DATE	2011.10.26
BLOCK		SHEET	43

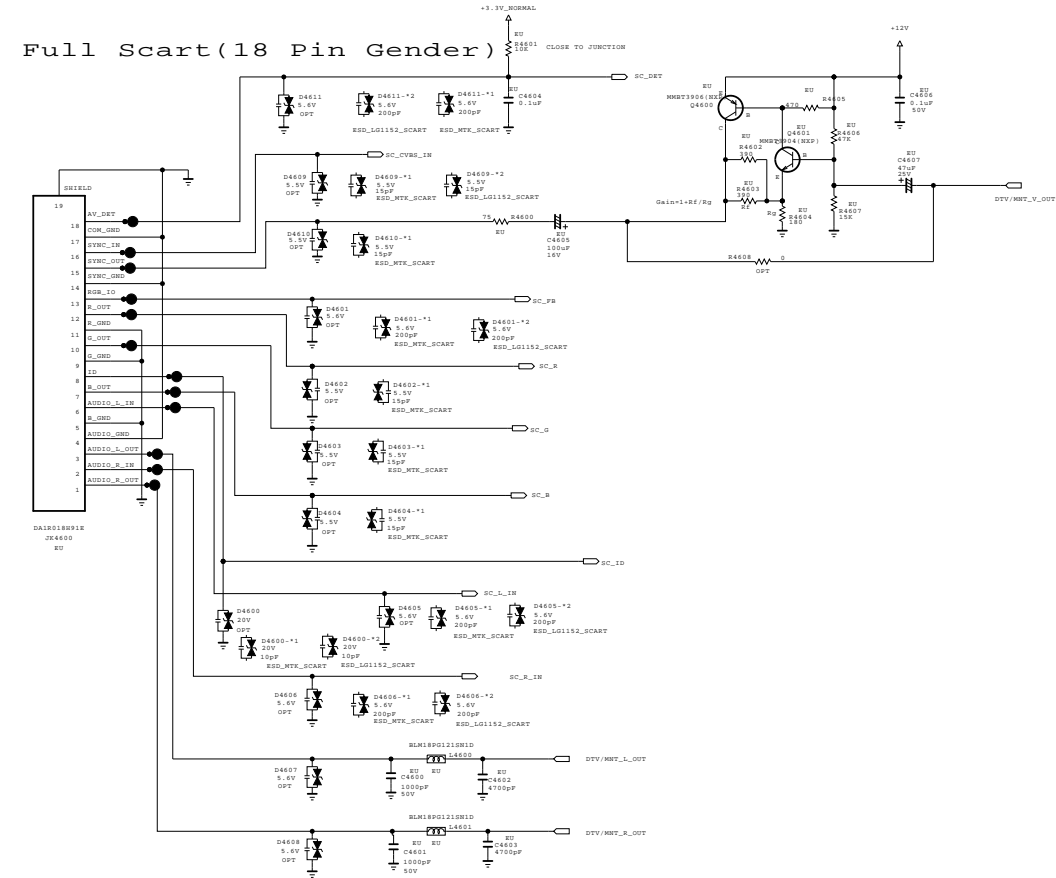

THE SYMBOL MARK OF THIS SCHEMATIC DIAGRAM INCORPORATES SPECIAL FEATURES IMPORTANT FOR PROTECTION FROM X-RADIATION. FILRE AND ELECTRICAL SHOCK HAZARDS, WHEN SERVICING IF IS ESSENTIAL THAT ONLY MANUFACTURES SPECIFIED PARTS BE USED FOR THE CRITICAL COMPONENTS IN THE SYMBOL MARK OF THE SCHEMATIC.

SECRET
LGElectronics



MODEL	SCART GENDER	DATE	2011.10.26
BLOCK		SHEET	46 /

ZigBee_Radio Pulse M_REMOTE OPTION

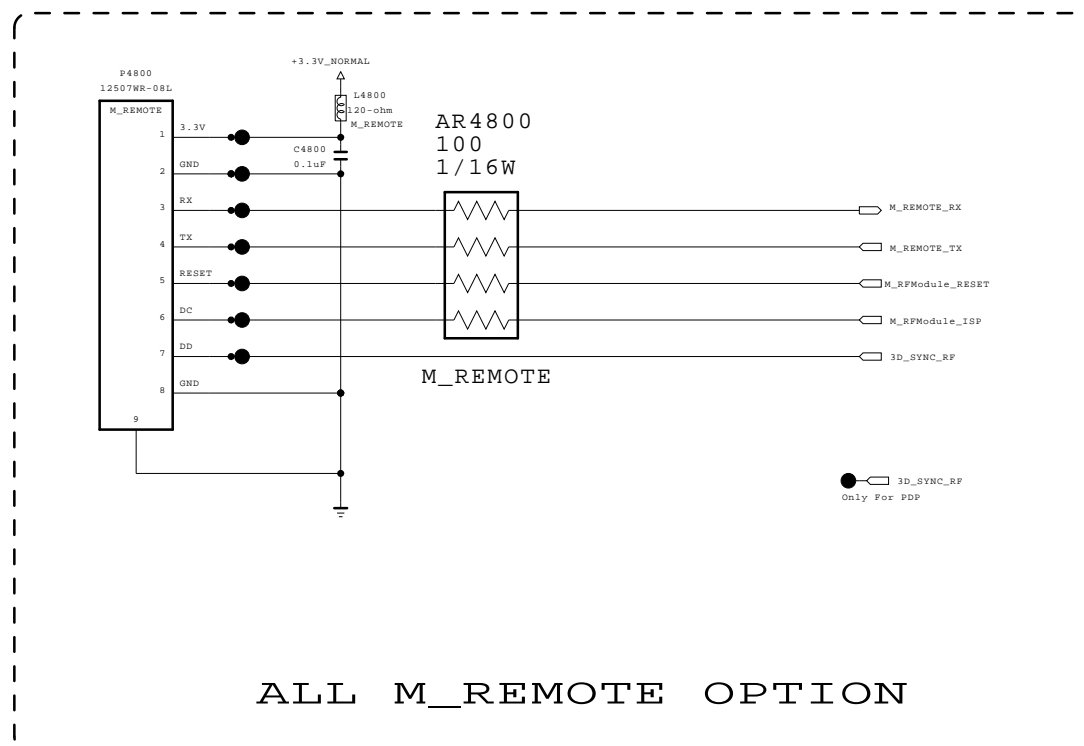

THE SYMBOL MARK OF THIS SCHEMATIC DIAGRAM INCORPORATES SPECIAL FEATURES IMPORTANT FOR PROTECTION FROM X-RADIATION. FILRE AND ELECTRICAL SHOCK HAZARDS, WHEN SERVICING IF IS ESSENTIAL THAT ONLY MANUFACTURES SPECIFIED PARTS BE USED FOR THE CRITICAL COMPONENTS IN THE SYMBOL MARK OF THE SCHEMATIC.

SECRET
LGElectronics



MODEL	MOTION REMOTE	DATE	2011.11.21
BLOCK		SHEET	48 /

Ethernet Block

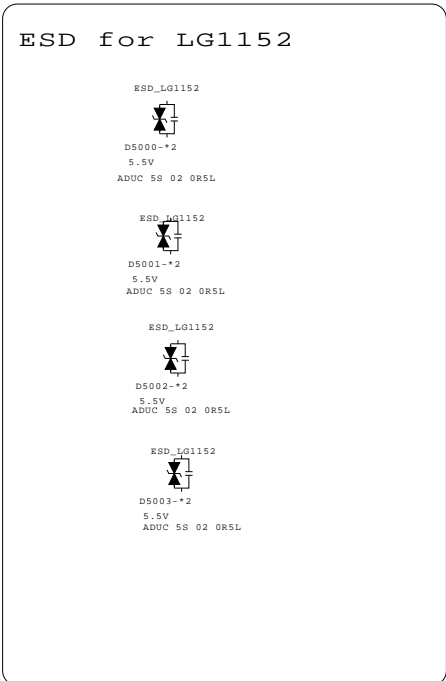
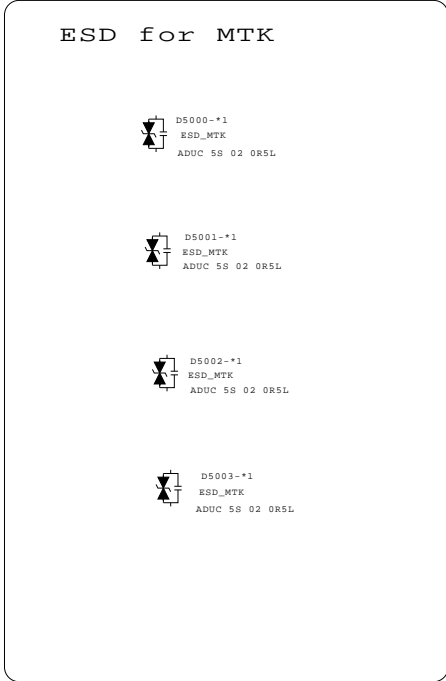
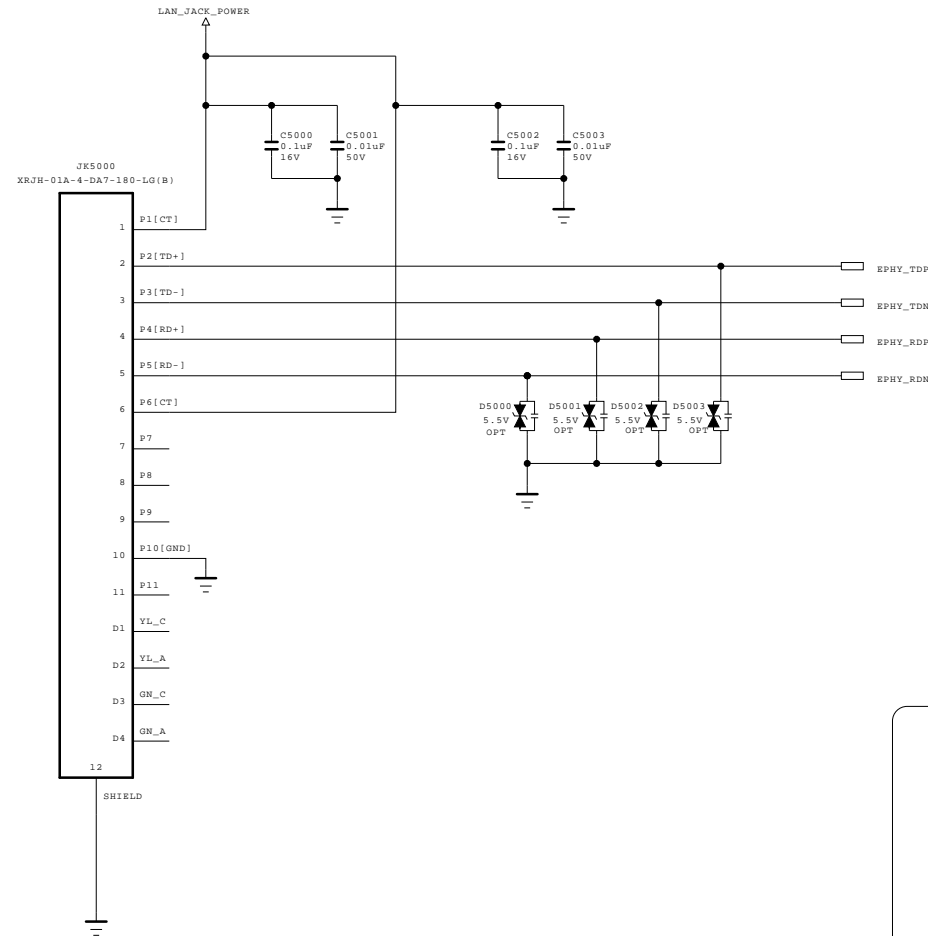

THE SYMBOL MARK OF THIS SCHEMATIC DIAGRAM INCORPORATES SPECIAL FEATURES IMPORTANT FOR PROTECTION FROM X-RADIATION. FILRE AND ELECTRICAL SHOCK HAZARDS, WHEN SERVICING IF IS ESSENTIAL THAT ONLY MANUFACTURES SPECIFIED PARTS BE USED FOR THE CRITICAL COMPONENTS IN THE SYMBOL MARK OF THE SCHEMATIC.

SECRET
LGElectronics



MODEL	LAN_VERTICAL	DATE	2011.11.23
BLOCK		SHEET	50

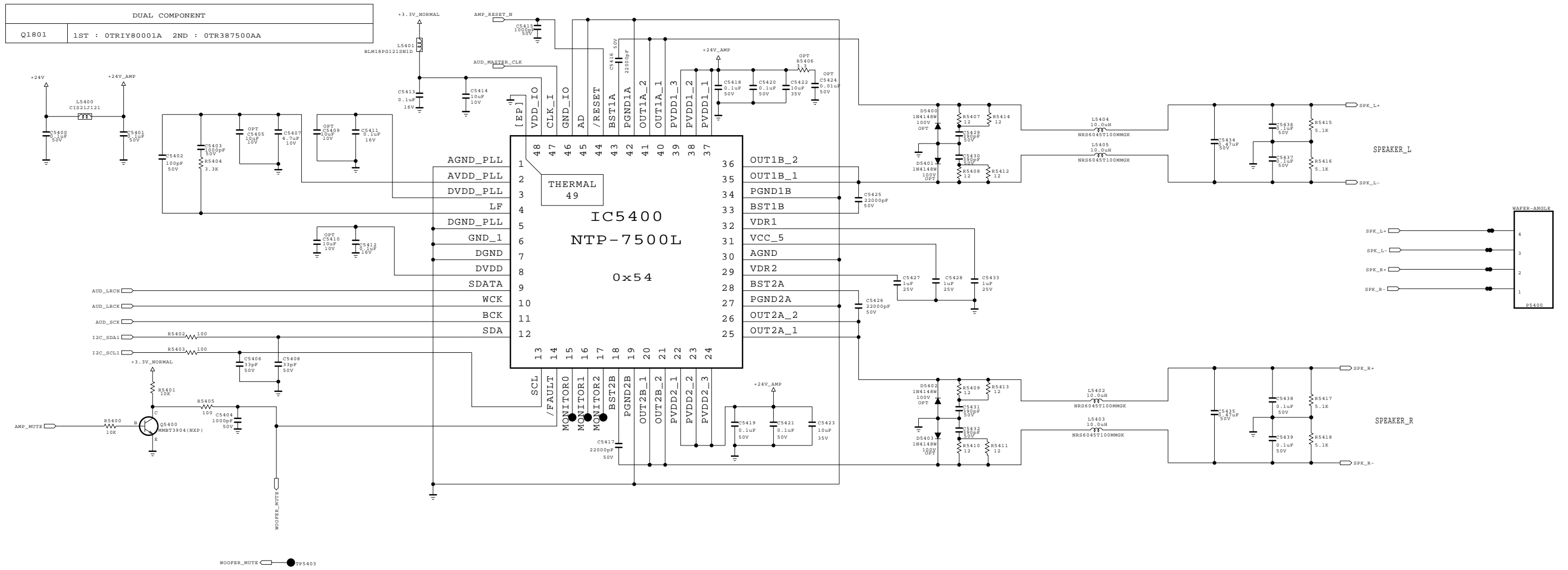

THE SYMBOL MARK OF THIS SCHEMATIC DIAGRAM INCORPORATES SPECIAL FEATURES IMPORTANT FOR PROTECTION FROM X-RADIATION. FILRE AND ELECTRICAL SHOCK HAZARDS, WHEN SERVICING IF IS ESSENTIAL THAT ONLY MANUFACTURES SPECIFIED PARTS BE USED FOR THE CRITICAL COMPONENTS IN THE SYMBOL MARK OF THE SCHEMATIC.

SECRET
LGElectronics



MODEL	AMP_NEO	DATE	2011.11.21
BLOCK		SHEET	54

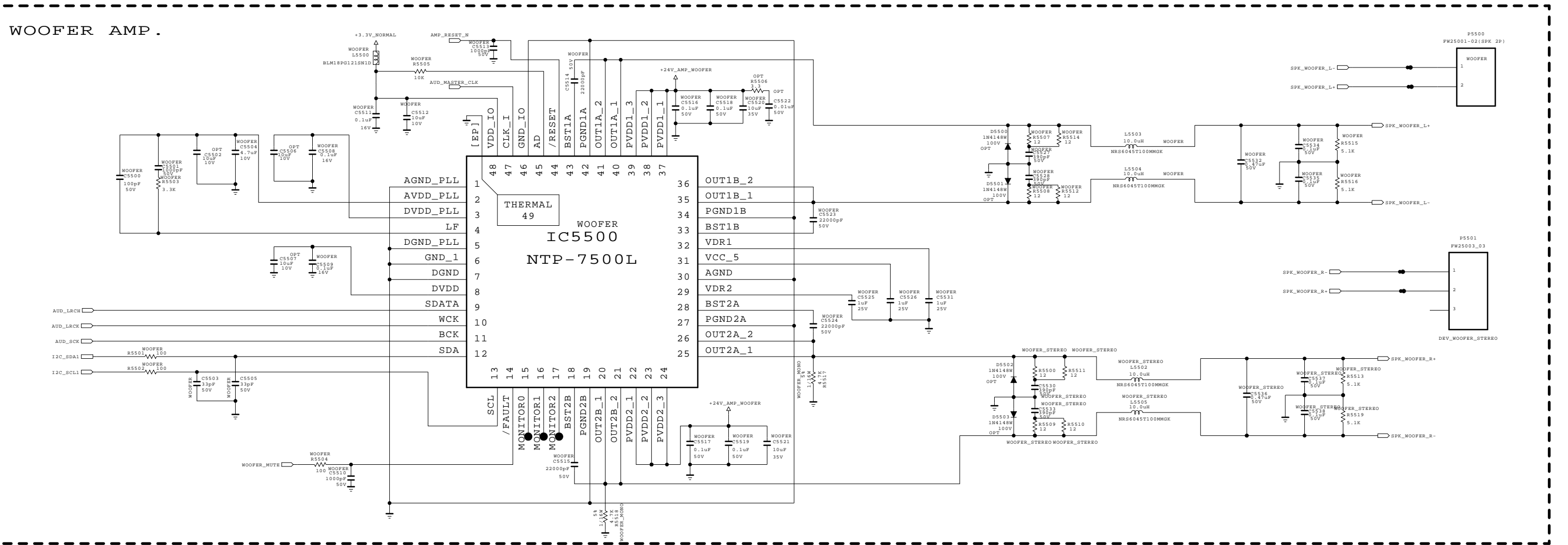
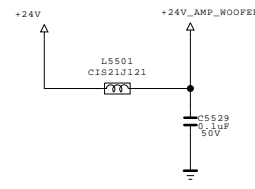



THE SYMBOL MARK OF THIS SCHEMATIC DIAGRAM INCORPORATES SPECIAL FEATURES IMPORTANT FOR PROTECTION FROM X-RADIATION. FILRE AND ELECTRICAL SHOCK HAZARDS, WHEN SERVICING IF IS ESSENTIAL THAT ONLY MANUFACTURES SPECIFIED PARTS BE USED FOR THE CRITICAL COMPONENTS IN THE SYMBOL MARK OF THE SCHEMATIC.

SECRET
LGElectronics

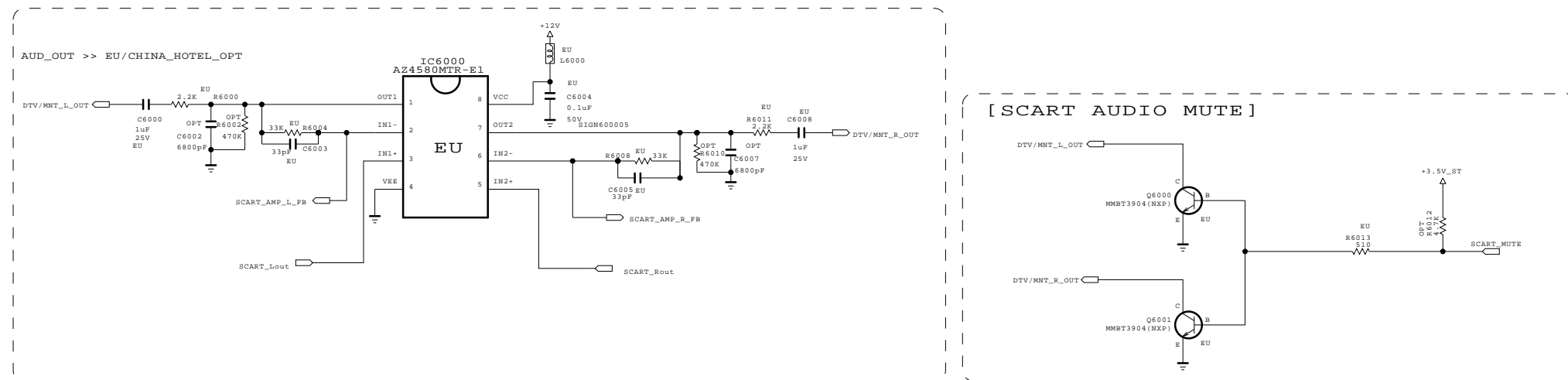

MODEL		DATE	
BLOCK		SHEET	



THE  SYMBOL MARK OF THIS SCHEMATIC DIAGRAM INCORPORATES SPECIAL FEATURES IMPORTANT FOR PROTECTION FROM X-RADIATION. FILRE AND ELECTRICAL SHOCK HAZARDS, WHEN SERVICING IF IS ESSENTIAL THAT ONLY MANUFACTURES SPECIFIED PARTS BE USED FOR THE CRITICAL COMPONENTS IN THE  SYMBOL MARK OF THE SCHEMATIC.

SECRET
LGElectronics



MODEL	SCART AUDIO AMP	DATE	2011.11.21
BLOCK		SHEET	60 /

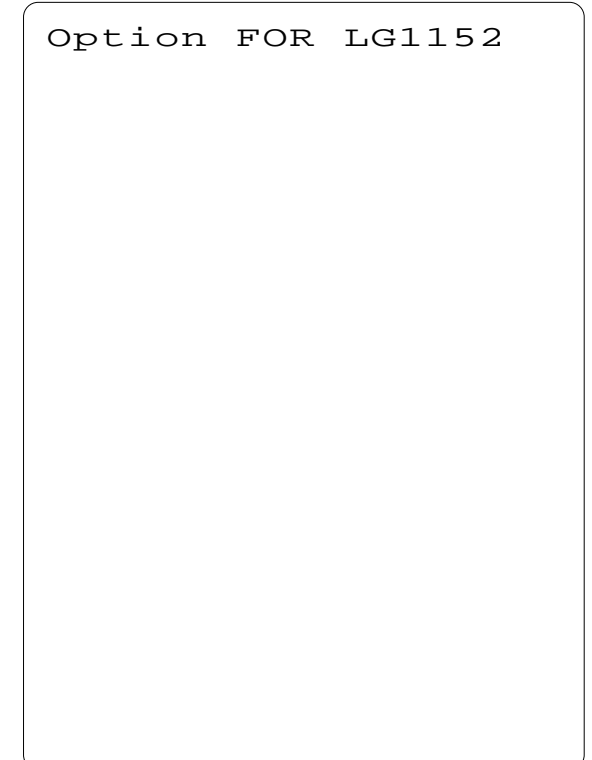
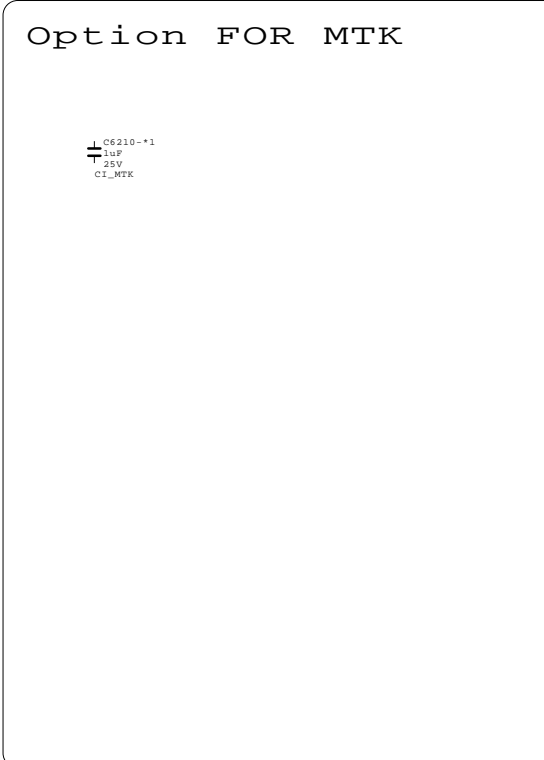
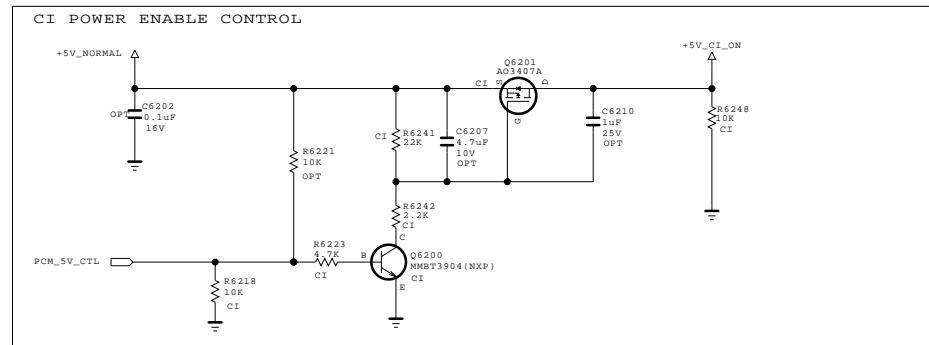

THE SYMBOL MARK OF THIS SCHEMATIC DIAGRAM INCORPORATES SPECIAL FEATURES IMPORTANT FOR PROTECTION FROM X-RADIATION. FILRE AND ELECTRICAL SHOCK HAZARDS, WHEN SERVICING IF IS ESSENTIAL THAT ONLY MANUFACTURES SPECIFIED PARTS BE USED FOR THE CRITICAL COMPONENTS IN THE SYMBOL MARK OF THE SCHEMATIC.

SECRET
LGElectronics



MODEL	CI SLOT	DATE	2011.10.31
BLOCK		SHEET	62 /

EARPHONE AMP

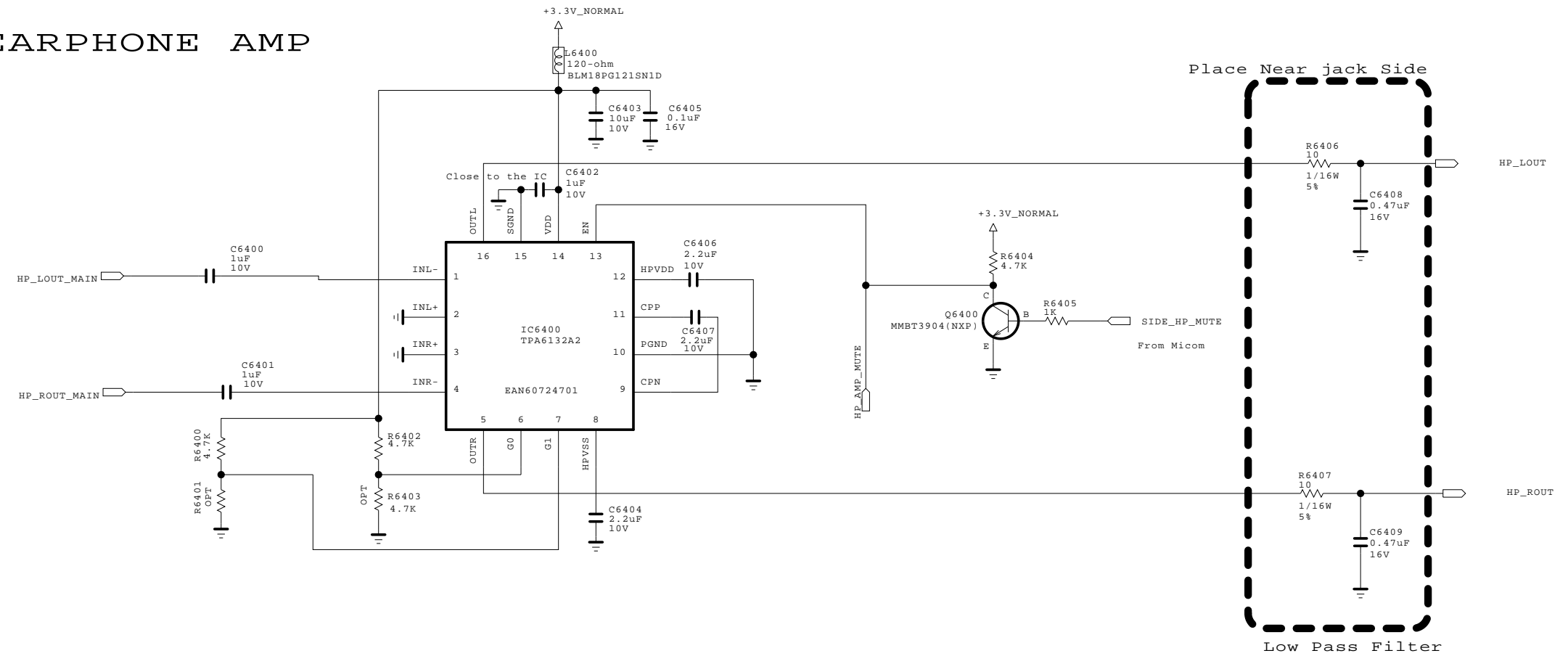

THE SYMBOL MARK OF THIS SCHEMATIC DIAGRAM INCORPORATES SPECIAL FEATURES IMPORTANT FOR PROTECTION FROM X-RADIATION. FILRE AND ELECTRICAL SHOCK HAZARDS, WHEN SERVICING IF IS ESSENTIAL THAT ONLY MANUFACTURES SPECIFIED PARTS BE USED FOR THE CRITICAL COMPONENTS IN THE SYMBOL MARK OF THE SCHEMATIC.

SECRET
LGElectronics

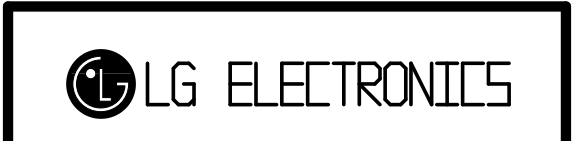

MODEL	HEADPHONE AMP	DATE	2011.06.29
BLOCK		SHEET	61 /

T/C/S & H/NIM & T2/C TUNER (EU & CHINA)

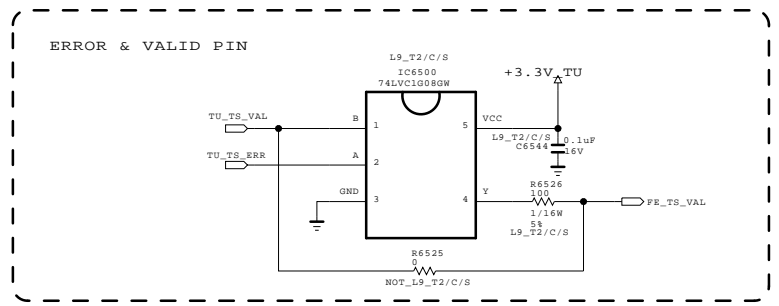
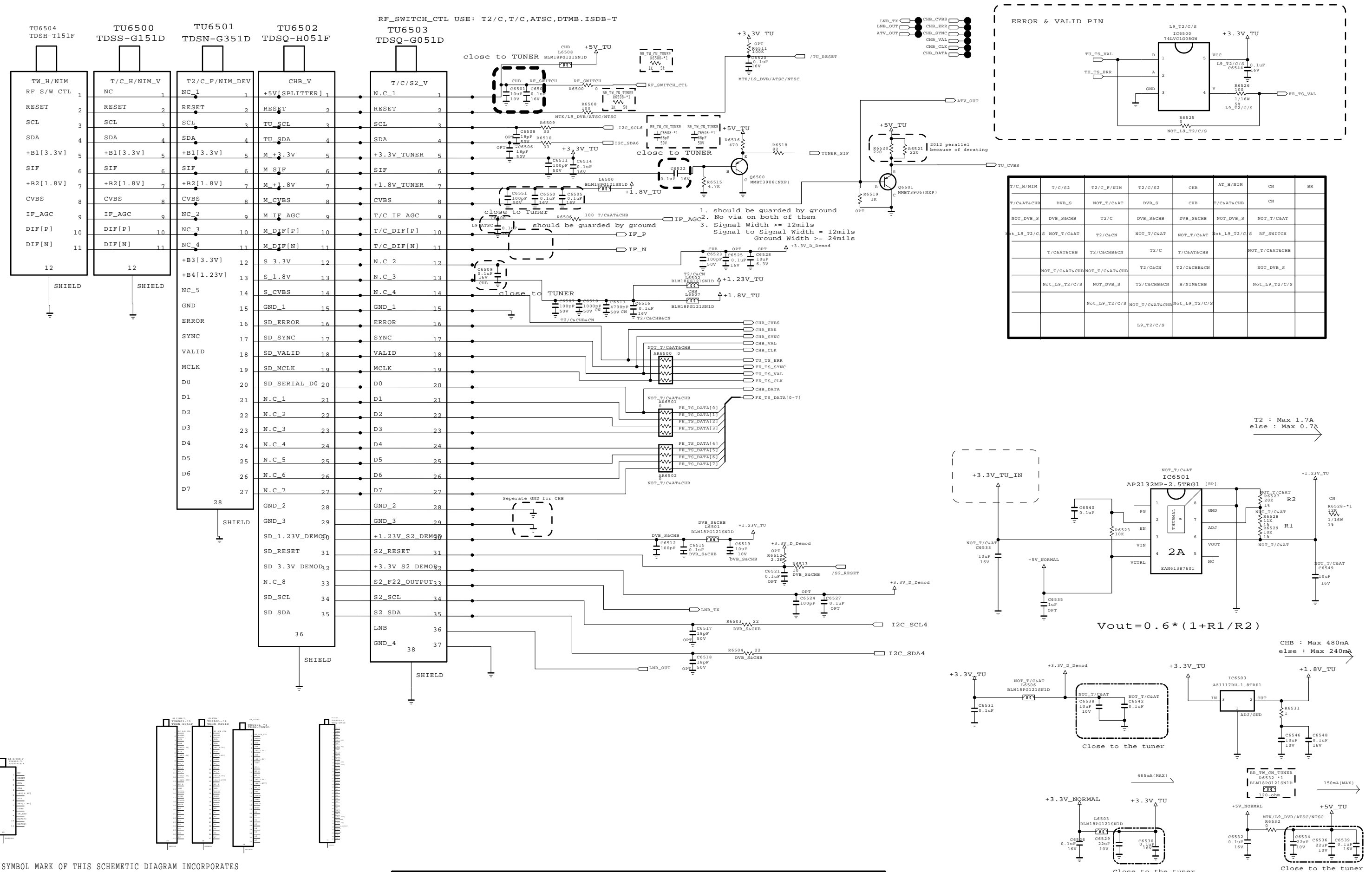

T/C/H/NIM	T/C/S2	T2/C_F/NIM_DEV	T2/C/S2	CHB	AT_H/NIM	CN	BR
T/C&AT&CHB	DVB_S	NOT_T/C&AT	DVB_S	CHB	F/C&AT&CHB	CN	
NOT_DVB_S	DVB_S&CHB	T2/C	DVB_S&CHB	DVB_S&CHB	NOT_DVB_S	NOT_T/C&AT	
FE_L9_T2/C/S	NOT_T/C&AT	T2/C&CN	NOT_T/C&AT	NOT_T/C&AT	Not_L9_T2/C/S	RF_SWITCH	
	T/C&AT&CHB	T2/C&CHB&CN	T2/C	T/C&AT&CHB		NOT_T/C&AT&CHB	
	Not_L9_T2/C/S	NOT_DVB_S	T2/C&CHB&CN	H/NIM&CHB		Not_L9_T2/C/S	
		Not_L9_T2/C/S	NOT_T/C&AT&CHB	Not_L9_T2/C/S			
			L9_T2/C/S				

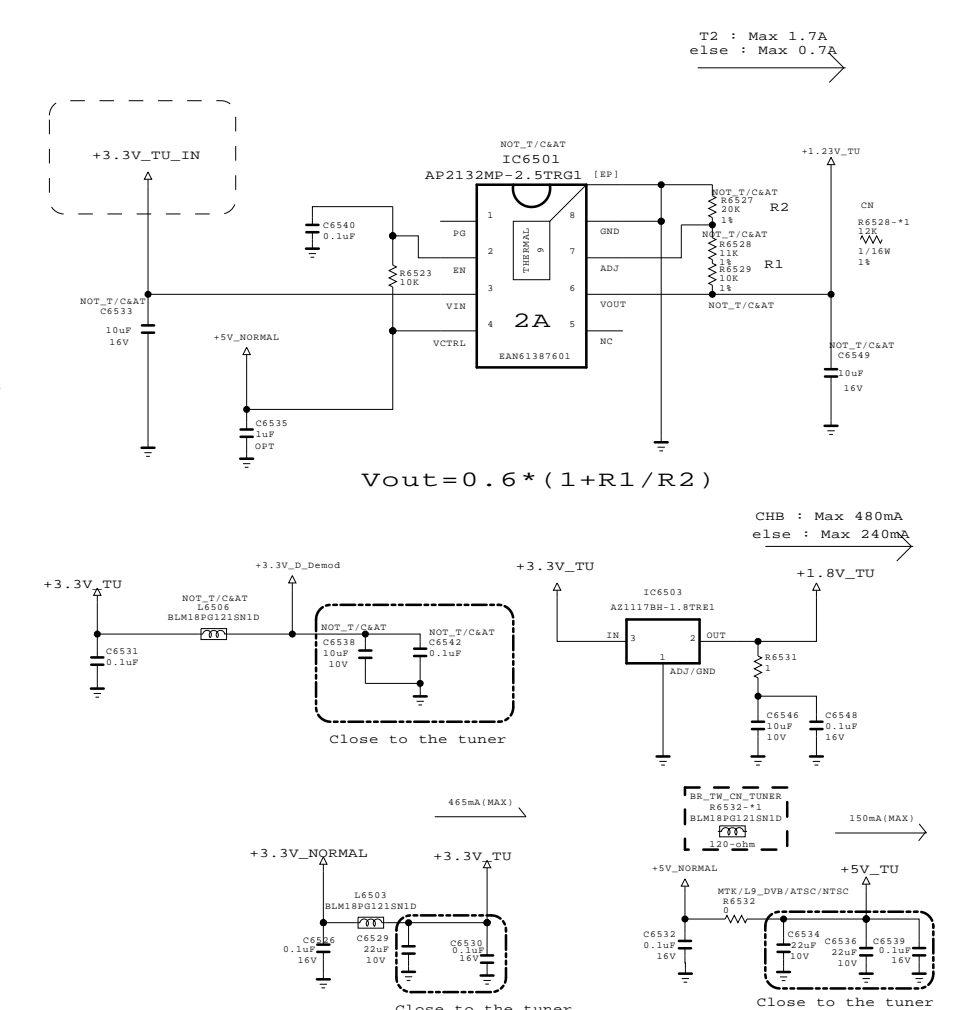

THE Δ SYMBOL MARK OF THIS SCHEMATIC DIAGRAM INCORPORATES SPECIAL FEATURES IMPORTANT FOR PROTECTION FROM X-RADIATION. FILRE AND ELECTRICAL SHOCK HAZARDS, WHEN SERVICING IF IS ESSENTIAL THAT ONLY MANUFACTURERS SPECIFIED PARTS BE USED FOR THE CRITICAL COMPONENTS IN THE Δ SYMBOL MARK OF THE SCHEMATIC.

SECRET
LGElectronics



MODEL	TUNER	DATE	2011.11.21
BLOCK		SHEET	65

DVB-S2 LNB Part Allegro

(Option:LNB)

DCDC_GND and A_GND are connected
 DCDC_GND and A_GND are connected in pin#27
 PCB_GND and A_GND are connected

Input trace widths should be sized to conduct at least 3A
 Output trace widths should be sized to conduct at least 2A

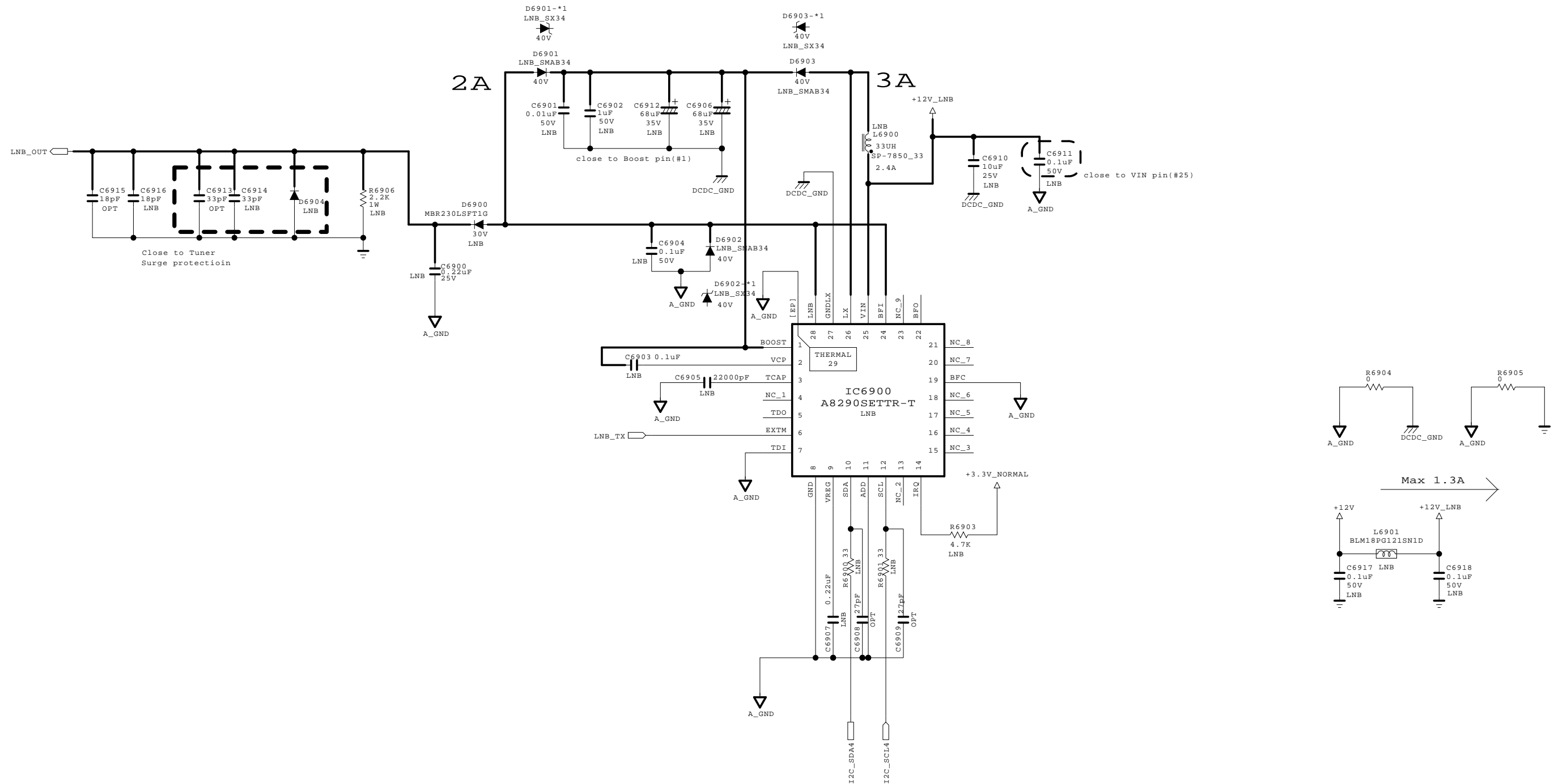

THE ⚠ SYMBOL MARK OF THIS SCHEMATIC DIAGRAM INCORPORATES SPECIAL FEATURES IMPORTANT FOR PROTECTION FROM X-RADIATION. FILRE AND ELECTRICAL SHOCK HAZARDS, WHEN SERVICING IF IS ESSENTIAL THAT ONLY MANUFACTURES SPECIFIED PARTS BE USED FOR THE CRITICAL COMPONENTS IN THE ⚠ SYMBOL MARK OF THE SCHEMATIC.

SECRET
 LGElectronics

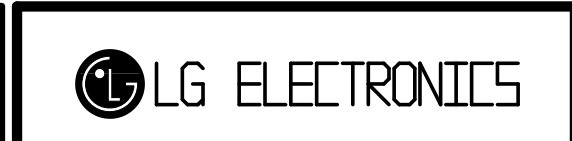

MODEL	LNB	DATE	2011.11.21
BLOCK		SHEET	69 /

[51Pin LVDS Connector]
(For PHD FRC3 HS_LVDS)

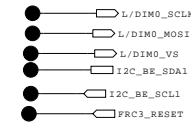
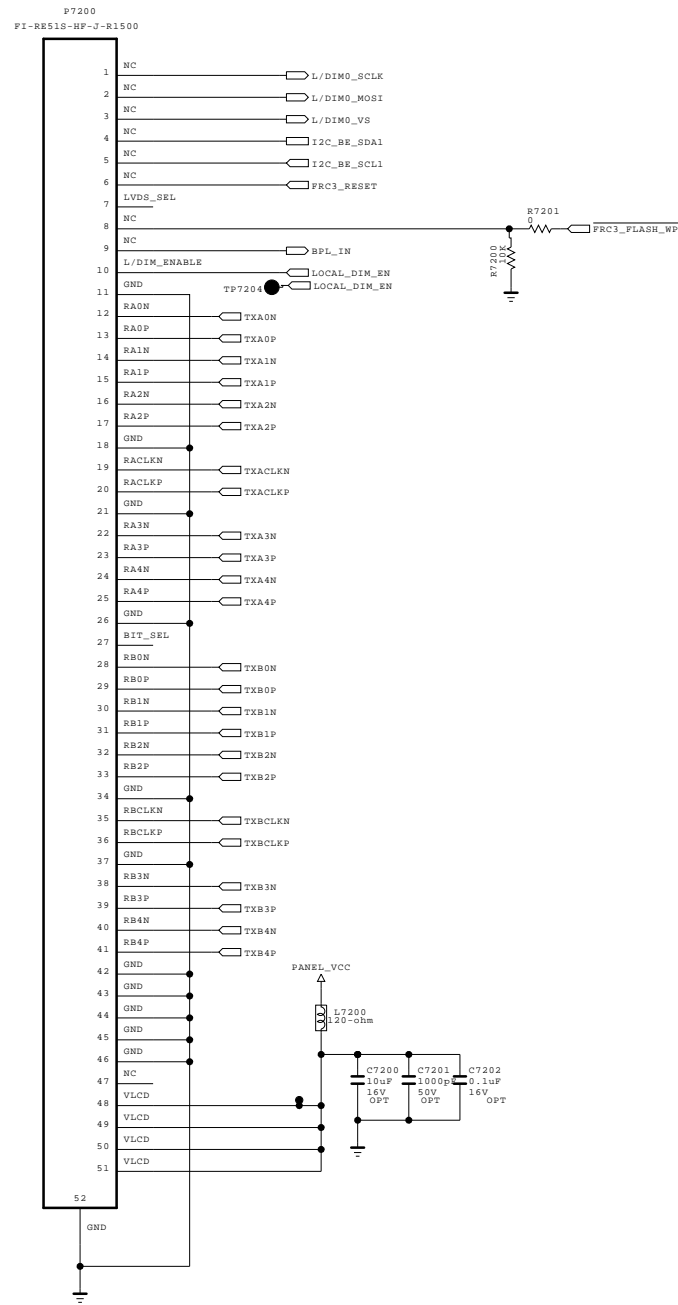

THE SYMBOL MARK OF THIS SCHEMATIC DIAGRAM INCORPORATES SPECIAL FEATURES IMPORTANT FOR PROTECTION FROM X-RADIATION. FILRE AND ELECTRICAL SHOCK HAZARDS, WHEN SERVICING IF IS ESSENTIAL THAT ONLY MANUFACTURES SPECIFIED PARTS BE USED FOR THE CRITICAL COMPONENTS IN THE SYMBOL MARK OF THE SCHEMATIC.

SECRET
LGElectronics



MODEL	LG1152 A0	DATE	
BLOCK	Interface block	SHEET	72 / 100

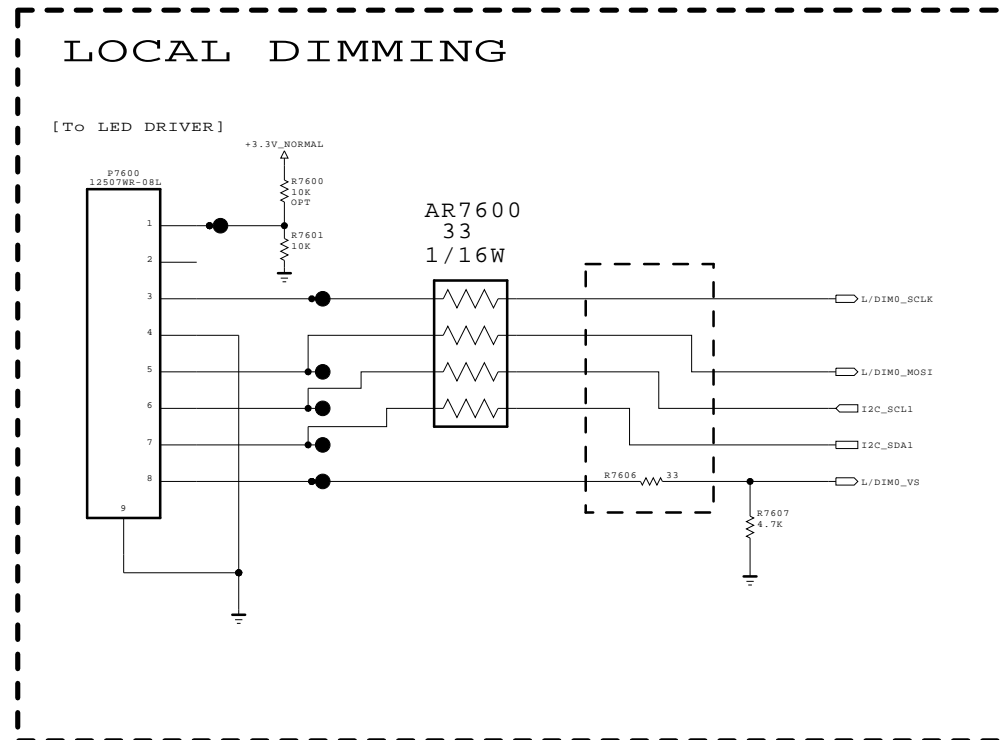

THE SYMBOL MARK OF THIS SCHEMATIC DIAGRAM INCORPORATES SPECIAL FEATURES IMPORTANT FOR PROTECTION FROM X-RADIATION. FILRE AND ELECTRICAL SHOCK HAZARDS, WHEN SERVICING IF IS ESSENTIAL THAT ONLY MANUFACTURES SPECIFIED PARTS BE USED FOR THE CRITICAL COMPONENTS IN THE SYMBOL MARK OF THE SCHEMATIC.

SECRET
LGElectronics



MODEL	LOCAL DIMMING	DATE	2011.11.21
BLOCK		SHEET	76 /

eMMC I/F

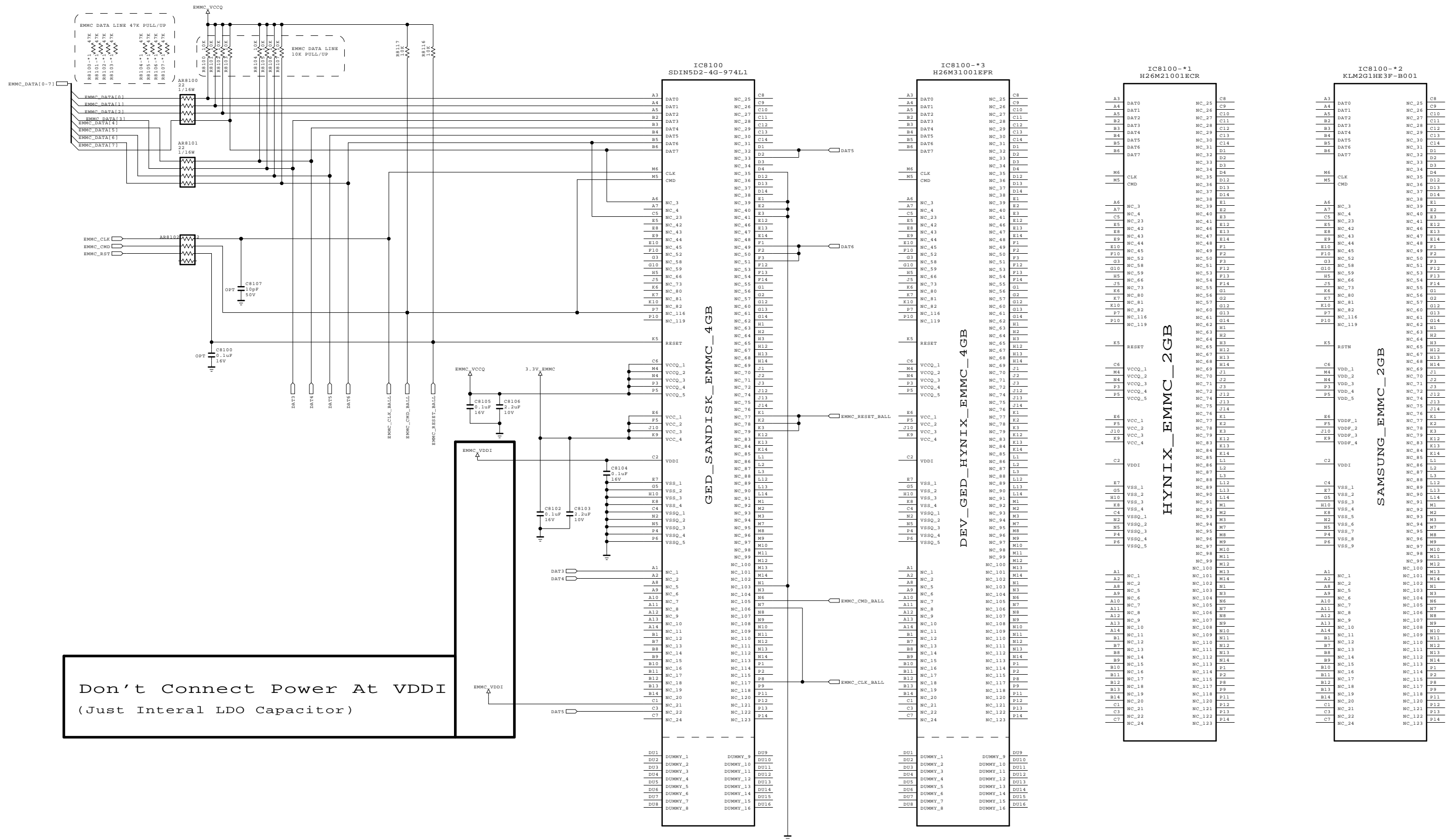

Don't Connect Power At VDDI
(Just Interual LDO Capacitor)



THE Δ SYMBOL MARK OF THIS SCHEMATIC DIAGRAM INCORPORATES SPECIAL FEATURES IMPORTANT FOR PROTECTION FROM X-RADIATION. FILRE AND ELECTRICAL SHOCK HAZARDS, WHEN SERVICING IF IS ESSENTIAL THAT ONLY MANUFACTURERS SPECIFIED PARTS BE USED FOR THE CRITICAL COMPONENTS IN THE Δ SYMBOL MARK OF THE SCHEMATIC.

SECRET
LGElectronics

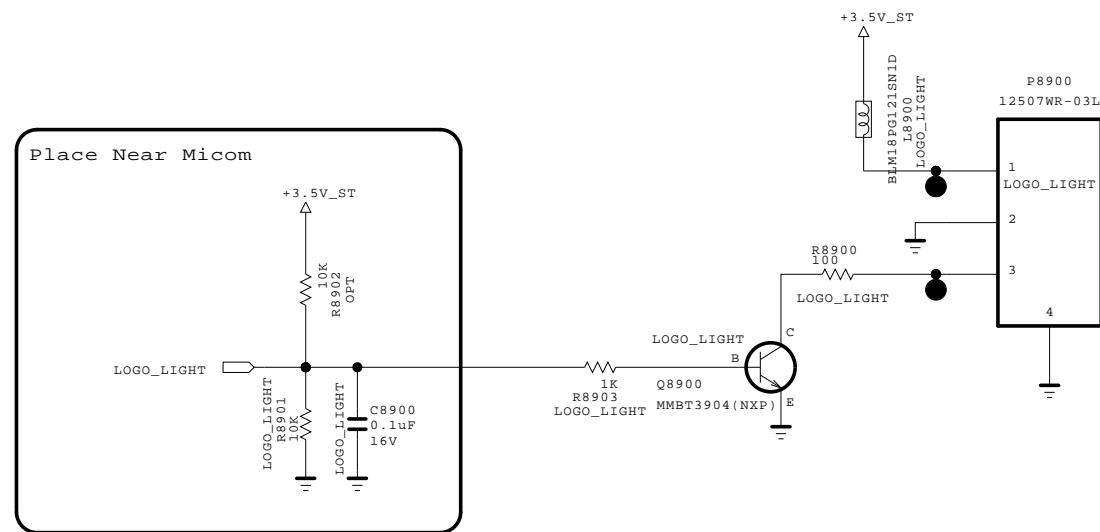

MODEL	eMMC	DATE	11.09.29
BLOCK		SHEET	81



THE  SYMBOL MARK OF THIS SCHEMATIC DIAGRAM INCORPORATES SPECIAL FEATURES IMPORTANT FOR PROTECTION FROM X-RADIATION. FILRE AND ELECTRICAL SHOCK HAZARDS, WHEN SERVICING IF IS ESSENTIAL THAT ONLY MANUFATURES SPECIFIED PARTS BE USED FOR THE CRITICAL COMPONENTS IN THE  SYMBOL MARK OF THE SCHEMATIC.

SECRET
LGElectronics



MODEL		DATE	
BLOCK		SHEET	/

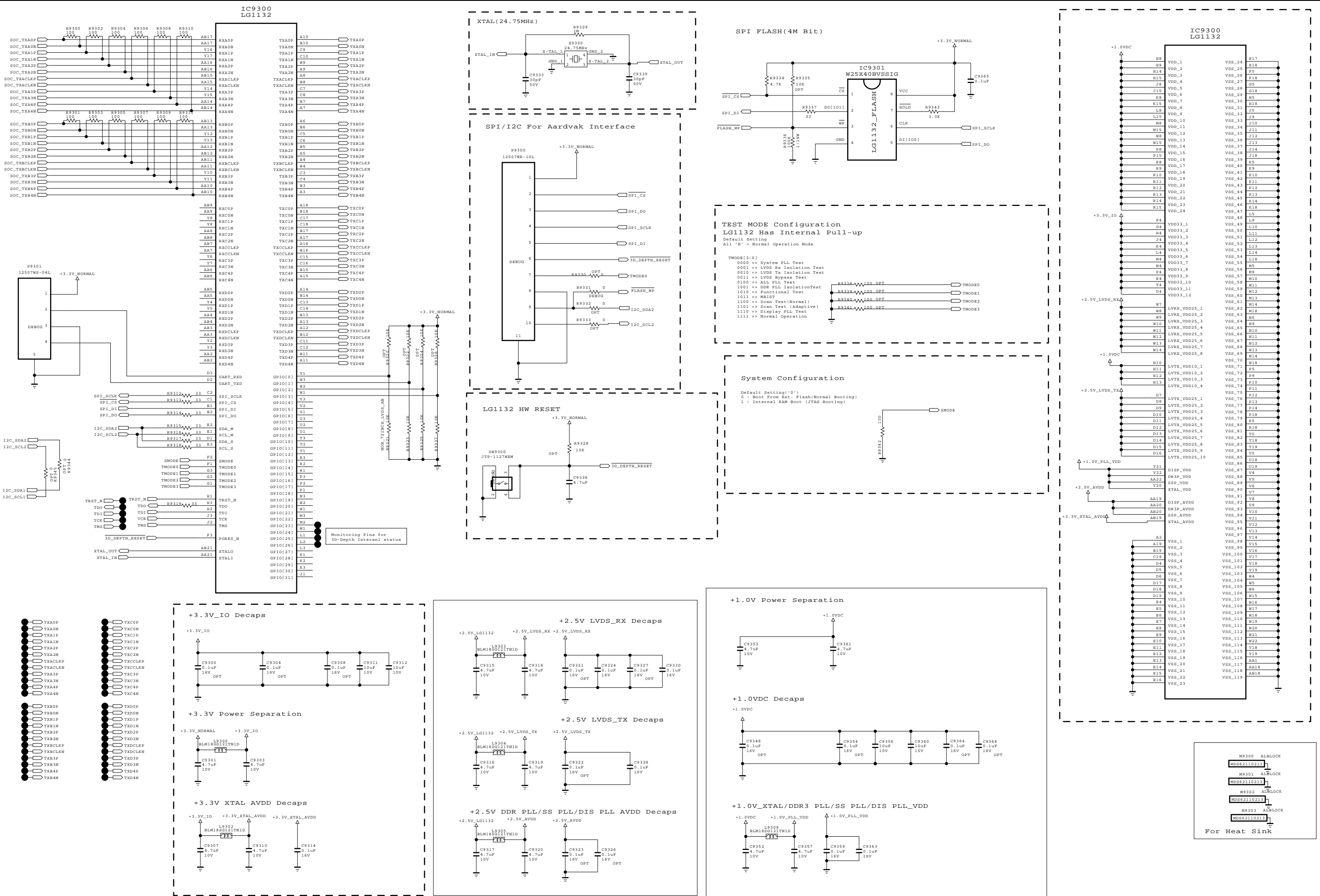

THE Δ SYMBOL MARK OF THIS SCHEMATIC DIAGRAM INCORPORATES SPECIAL FEATURES IMPORTANT FOR PROTECTION FROM X-RADIATION. FILRE AND ELECTRICAL SHOCK HAZARDS, WHEN SERVICING IF IS ESSENTIAL THAT ONLY MANUFACTURERS SPECIFIED PARTS BE USED FOR THE CRITICAL COMPONENTS IN THE Δ SYMBOL MARK OF THE SCHEMATIC.

SECRET
LGElectronics



MODEL	LG1152 B0	DATE	2011. 11. 28
BLOCK	3D Depth	SHEET	/

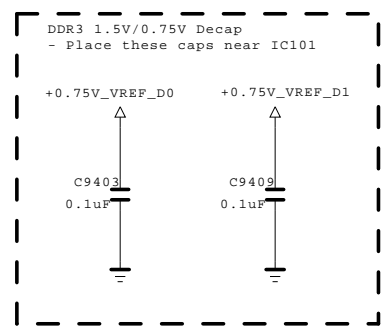
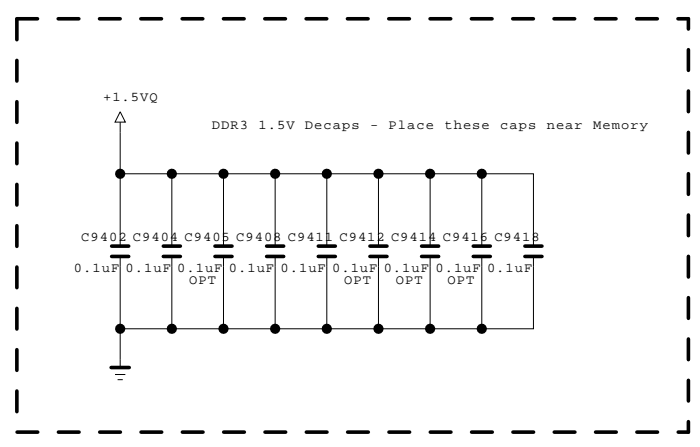
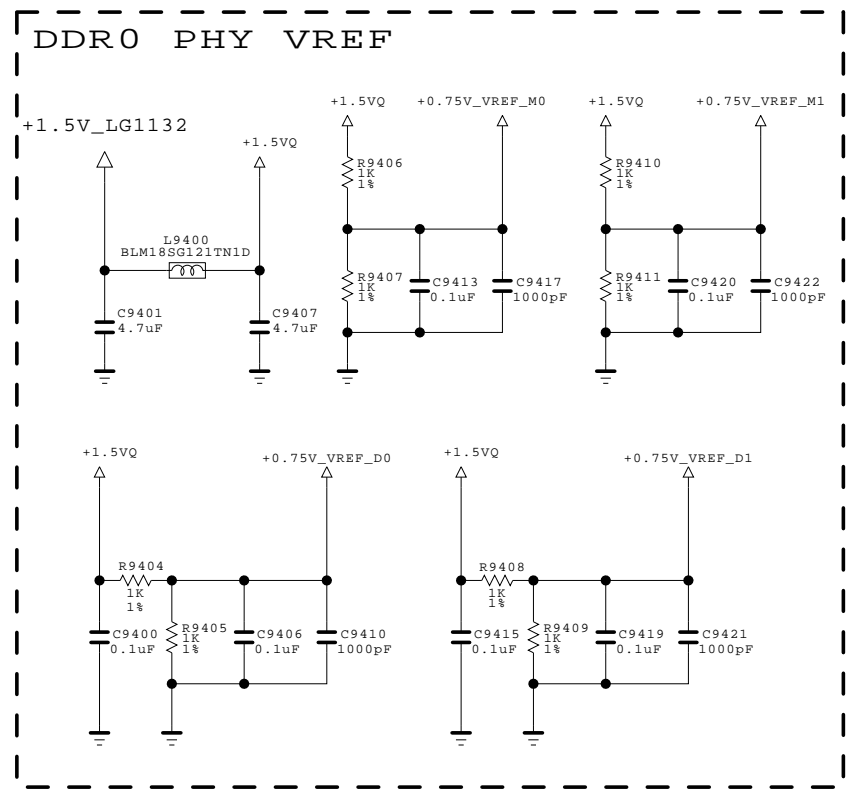
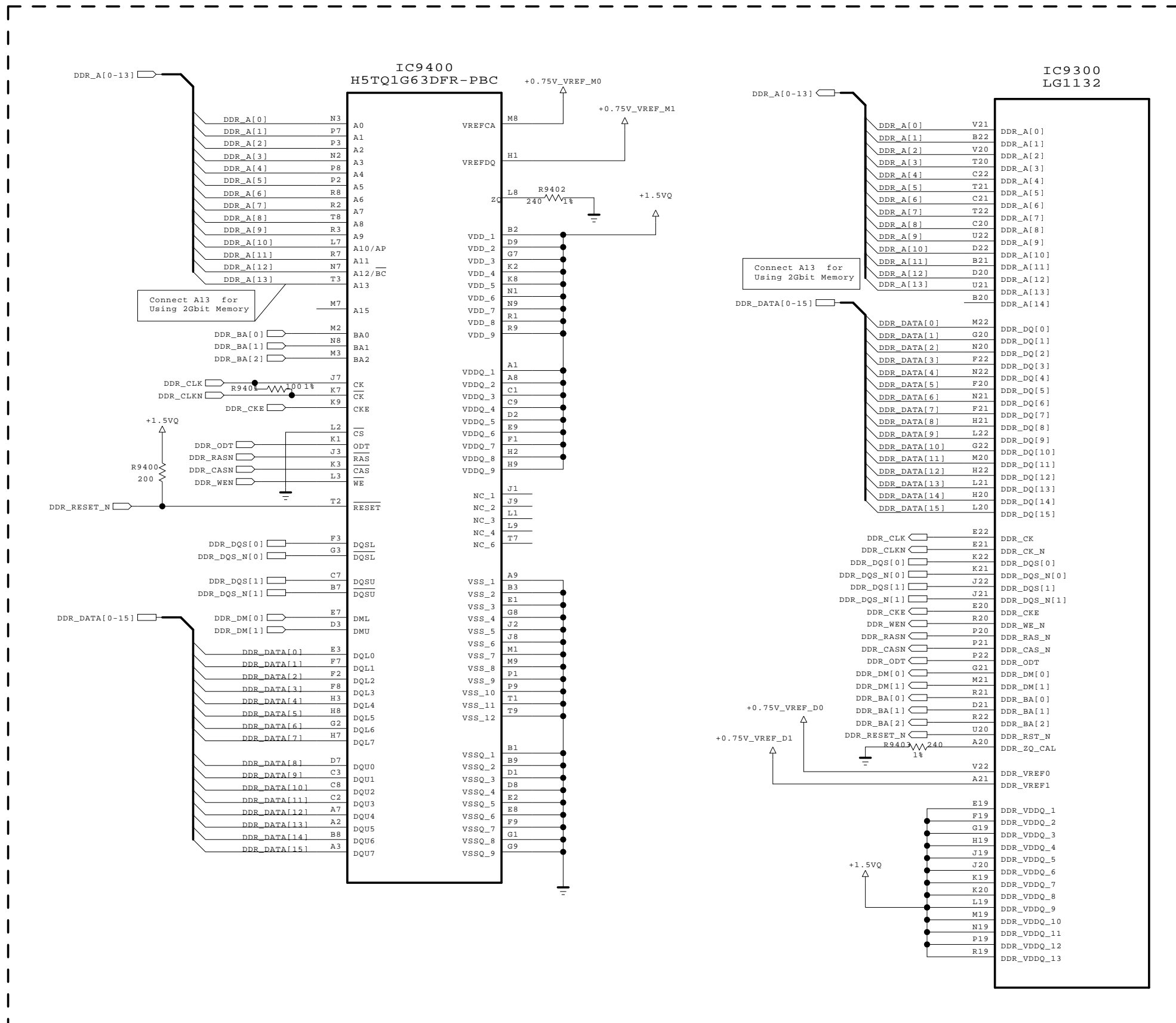

THE ⚠ SYMBOL MARK OF THIS SCHEMATIC DIAGRAM INCORPORATES SPECIAL FEATURES IMPORTANT FOR PROTECTION FROM X-RADIATION. FILRE AND ELECTRICAL SHOCK HAZARDS, WHEN SERVICING IF IS ESSENTIAL THAT ONLY MANUFACTURES SPECIFIED PARTS BE USED FOR THE CRITICAL COMPONENTS IN THE ⚠ SYMBOL MARK OF THE SCHEMATIC.

SECRET
LGElectronics



MODEL	LG1132 DDR3	DATE	2011. 06 .28
BLOCK	LG1132 DDR3	SHEET	/

3D-Depth Analog for 2.5V

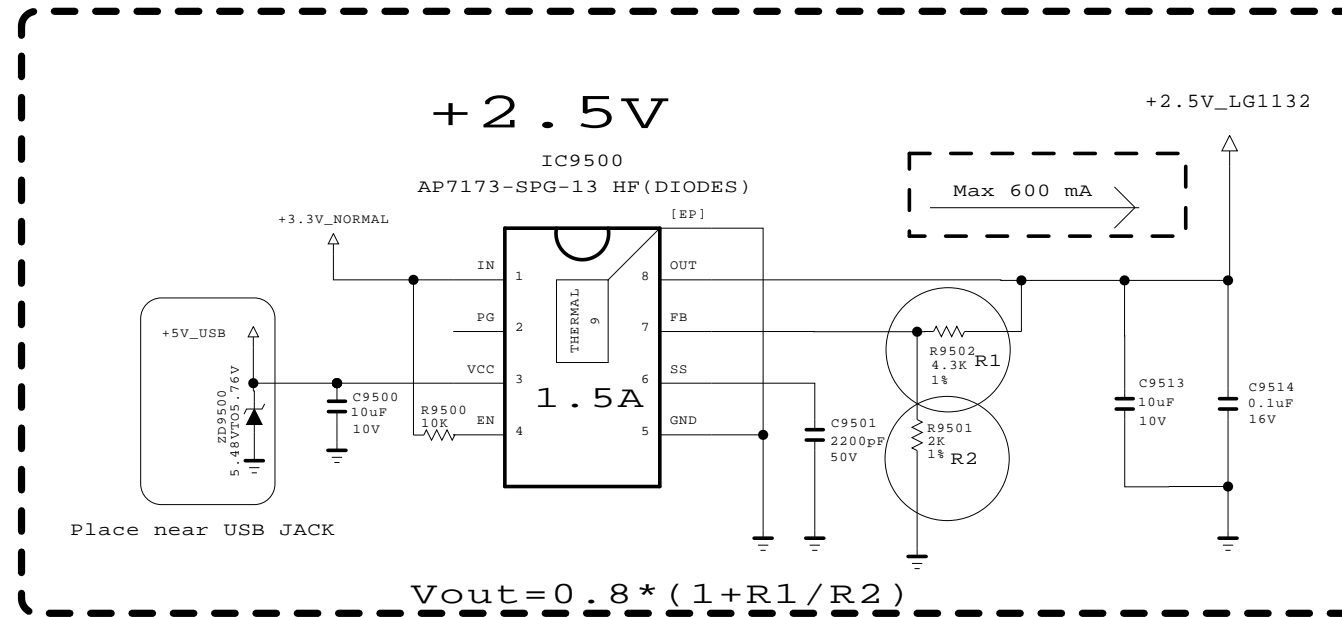
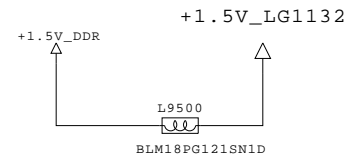

LG1152 for 1.0V

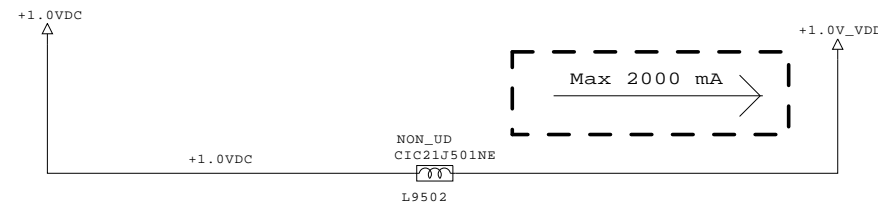

L9 CORE for 1.0V

(UD Model only / LG1132 DDR=792Mhz)

READY

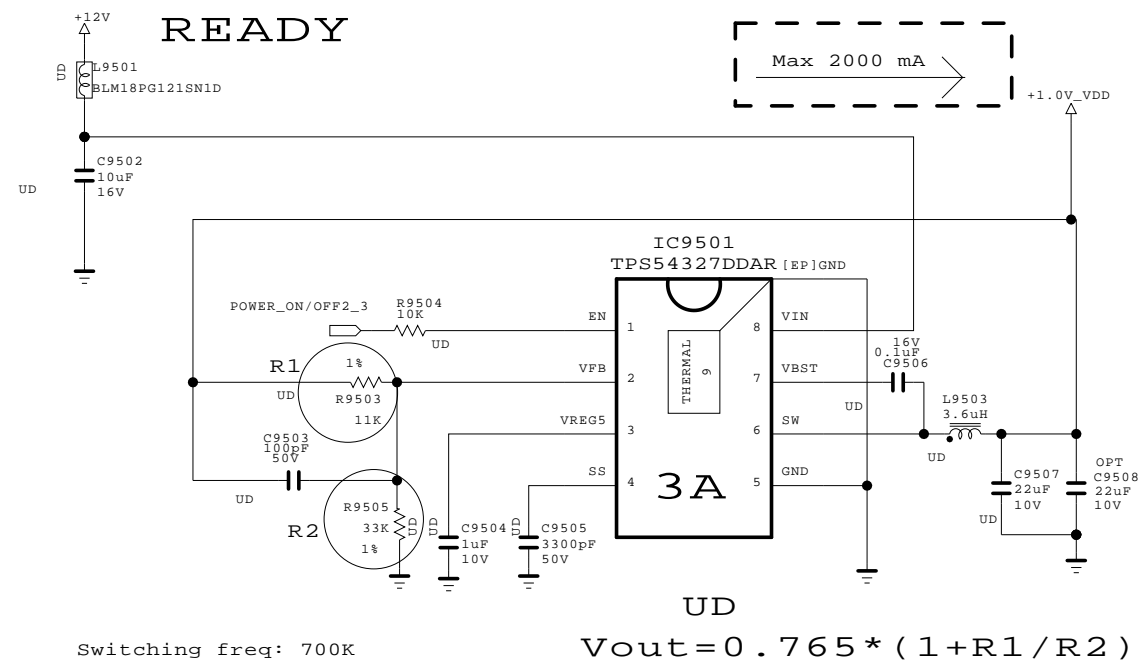

**NON UD Model

LG1132 DDR = 668Mhz
 LG1152 1.0V ==> IC2306
 LG1132 1.0V ==> IC2306

**UD Model

LG1132 DDR = 792Mhz
 LG1152 1.0V ==> IC2501
 LG1132 1.1V ==> IC2306

THE SYMBOL MARK OF THIS SCHEMATIC DIAGRAM INCORPORATES SPECIAL FEATURES IMPORTANT FOR PROTECTION FROM X-RADIATION. FILRE AND ELECTRICAL SHOCK HAZARDS, WHEN SERVICING IF IS ESSENTIAL THAT ONLY MANUFACTURES SPECIFIED PARTS BE USED FOR THE CRITICAL COMPONENTS IN THE SYMBOL MARK OF THE SCHEMATIC.

SECRET	LG ELECTRONICS
LGElectronics	

MODEL	LG1132 Power	DATE	2011. 06. 28
BLOCK	LG1132 POWER	SHEET	/

IR BLASTER

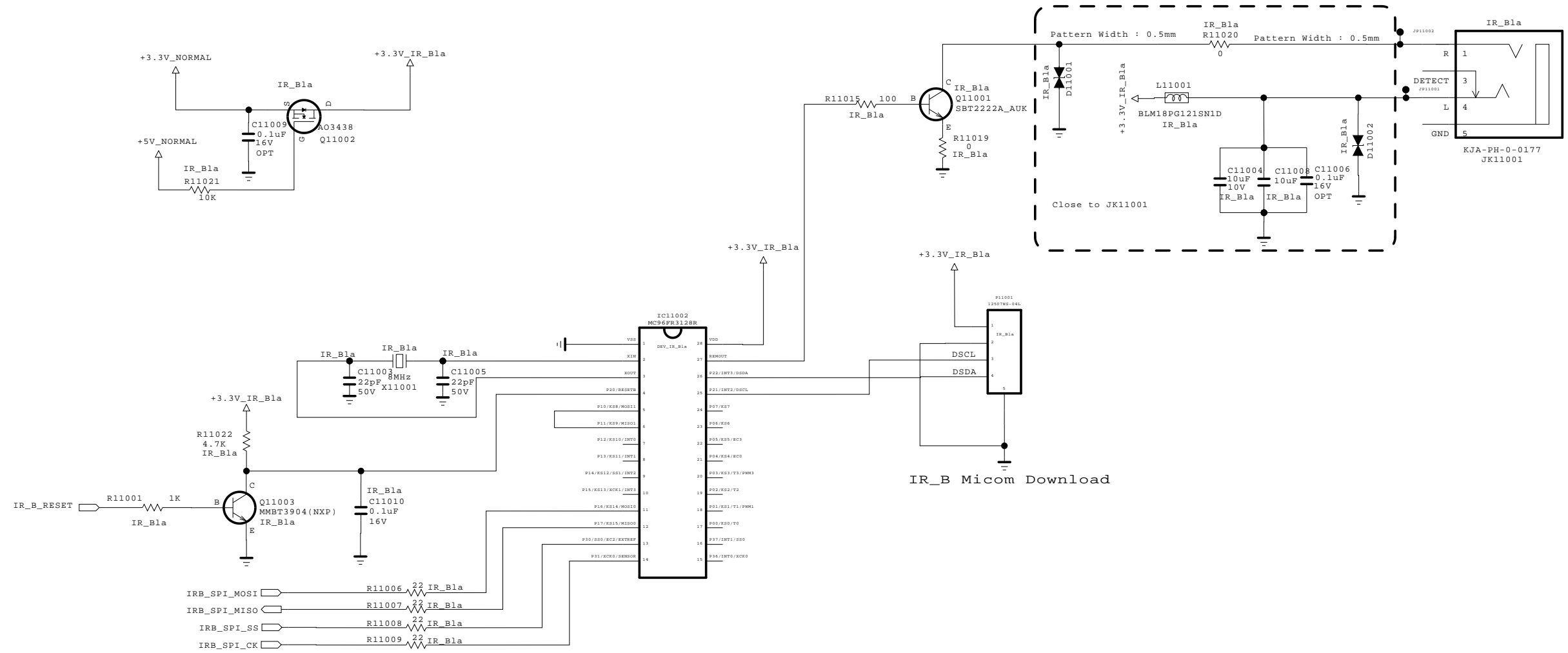

THE ⚠ SYMBOL MARK OF THIS SCHEMATIC DIAGRAM INCORPORATES SPECIAL FEATURES IMPORTANT FOR PROTECTION FROM X-RADIATION. FILRE AND ELECTRICAL SHOCK HAZARDS, WHEN SERVICING IF IS ESSENTIAL THAT ONLY MANUFACTURES SPECIFIED PARTS BE USED FOR THE CRITICAL COMPONENTS IN THE ⚠ SYMBOL MARK OF THE SCHEMATIC.

SECRET	LG ELECTRONICS
LGElectronics	

MODEL	LG1152 A1	DATE	2011. 06. 02
BLOCK	IR Blaster/Boost	SHEET	94 /

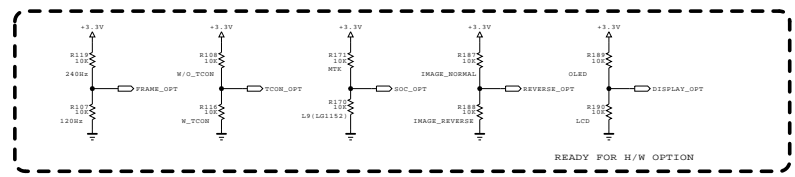
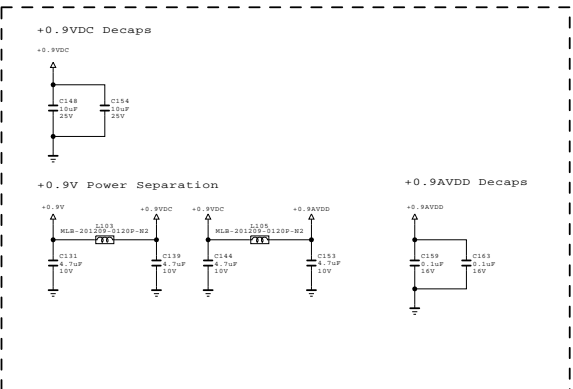
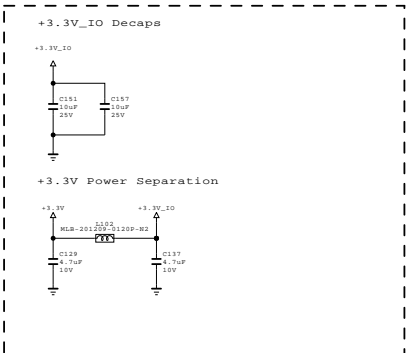
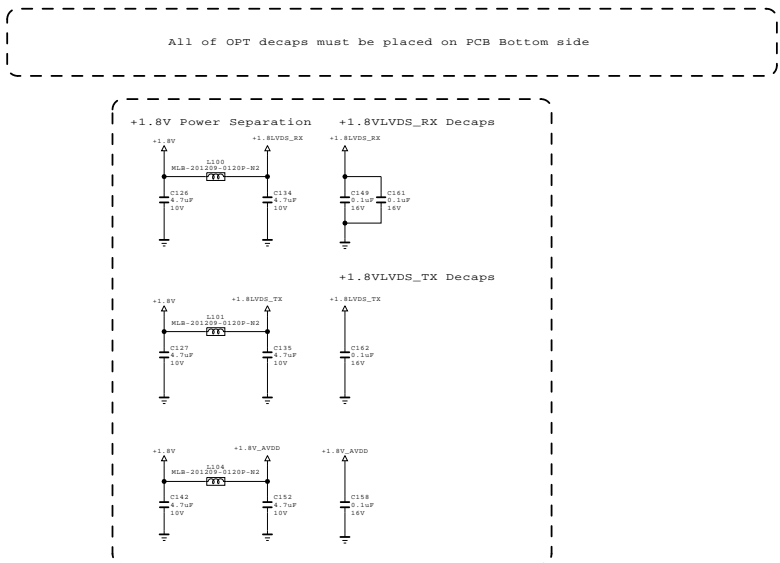
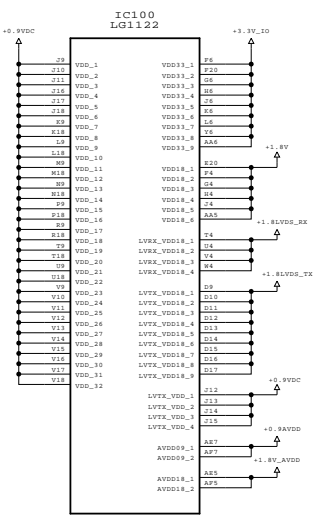
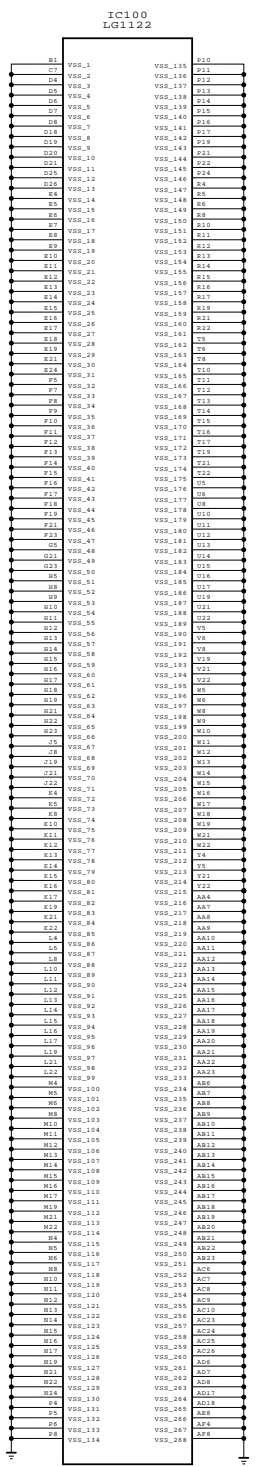
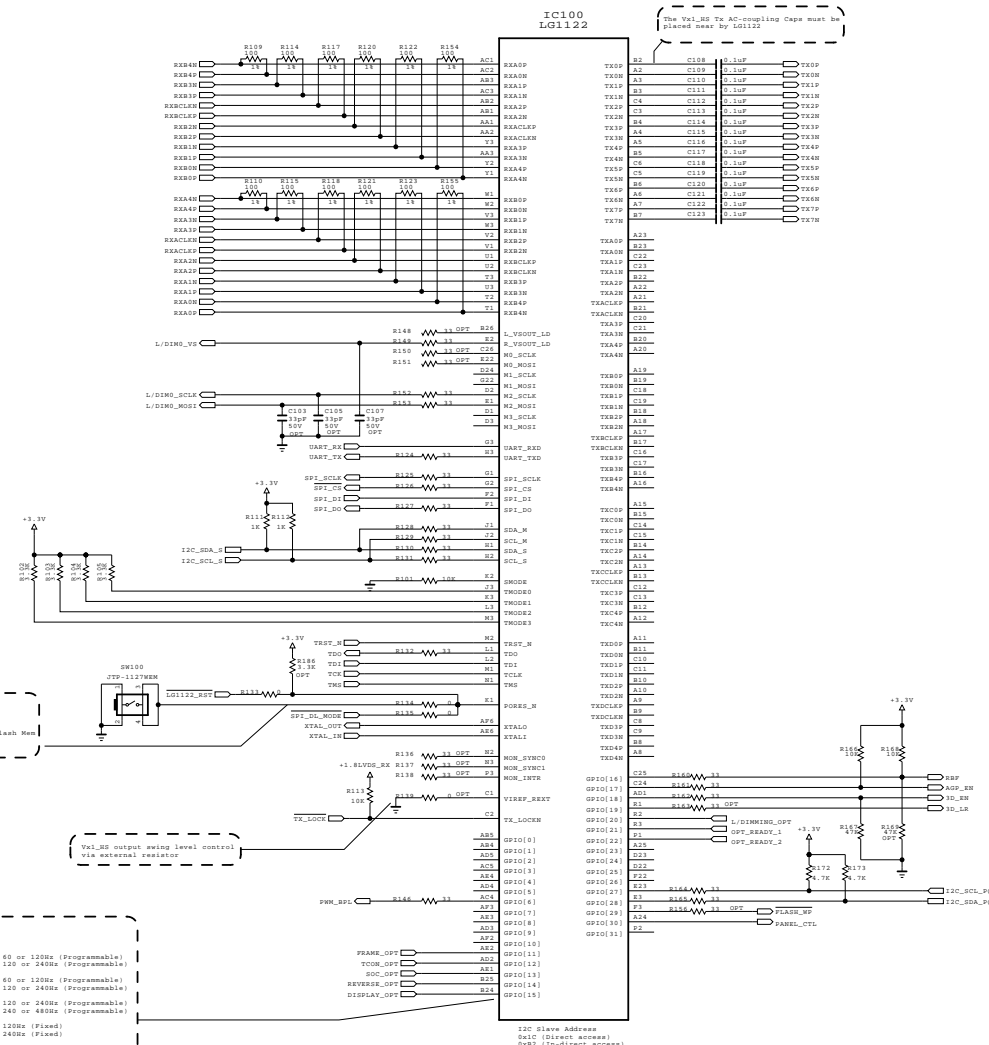

OPTION NO.	OPTION NAME	RES	LOW
11	FRAME_OPT	240Ω	120Ω
12	TOOL_OPT	W/NoTool_TOOR (for PCB3 JIG)	W/NoTool_TOOR
13	DOC_OPT	1Ω (LSI152)	W/R
14	IMAGE_OPT	IMAGE_NORMAL (for 72INCR)	IMAGE_OPT (for NOM_72INCR)
15	DISPLAY_OPT	OLSD	LCD
16	L/DIMMING_OPT	L/D_OR_FRC	L/D_OR_MAIN
17	OPT_READY_1	OPT	DefaUlt
18	OPT_READY_2	OPT	DefaUlt

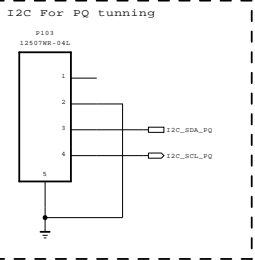
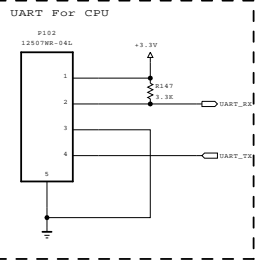
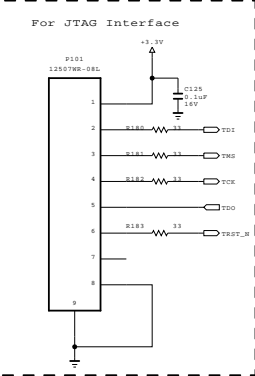
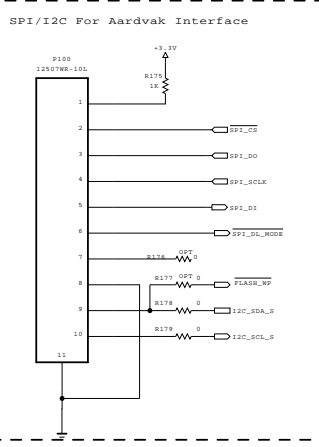
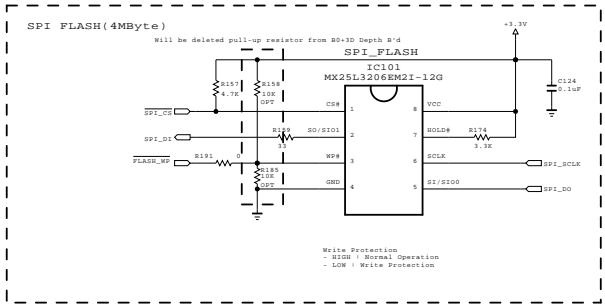
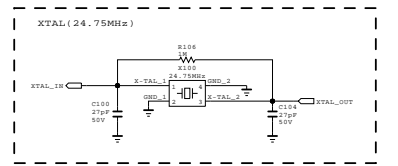

THE SYMBOL MARK OF THIS SCHEMATIC DIAGRAM INCORPORATES SPECIAL FEATURES IMPORTANT FOR PROTECTION FROM X-RADIATION. FILTR AND ELECTRICAL SHOCK HAZARDS, WHEN SERVICING IF IS ESSENTIAL THAT ONLY MANUFACTURERS SPECIFIED PARTS BE USED FOR THE CRITICAL COMPONENTS IN THE SYMBOL MARK OF THE SCHEMATIC.

SECRET
LGElectronics

LG ELECTRONICS

MODEL	240Hz Back-End Board	DATE	2011. 07. 05
BLOCK	PRC-III (LG1122)	SHEET	1 / 6

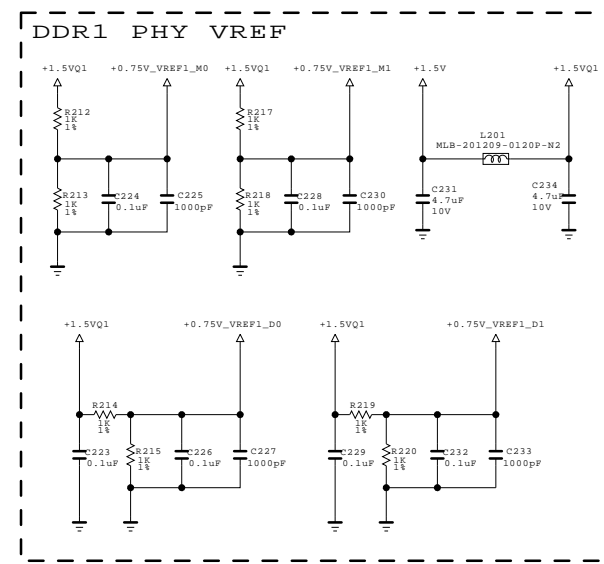
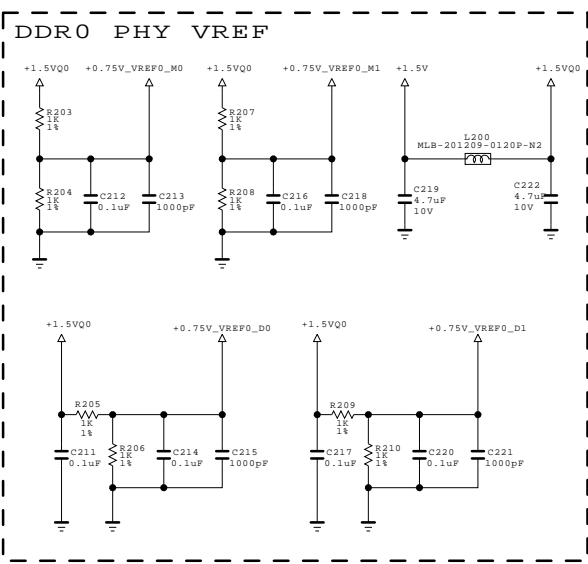
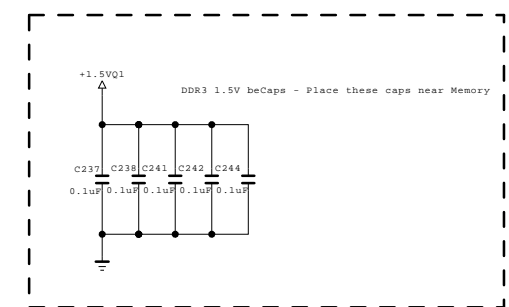
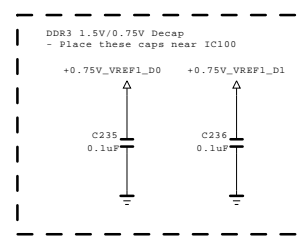
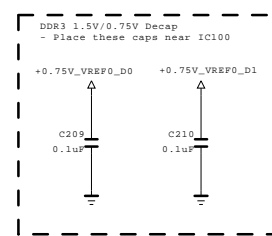
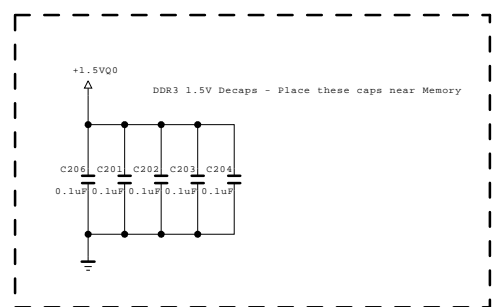
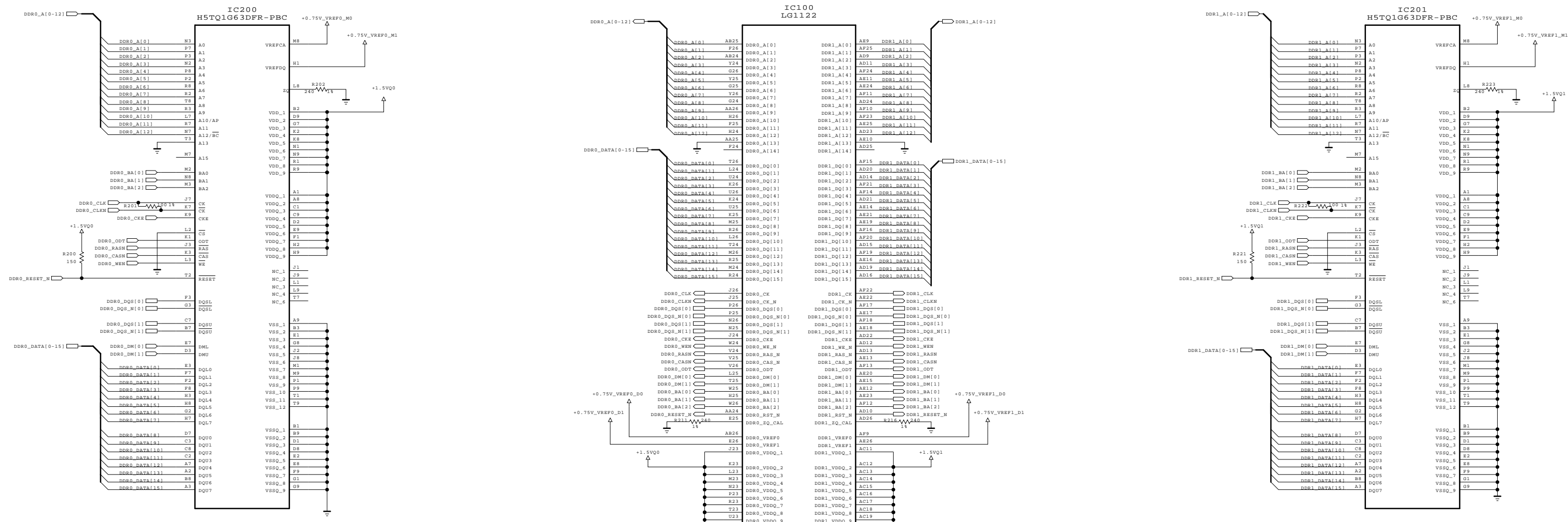

THE SYMBOL MARK OF THIS SCHEMATIC DIAGRAM INCORPORATES SPECIAL FEATURES IMPORTANT FOR PROTECTION FROM X-RADIATION. FILRE AND ELECTRICAL SHOCK HAZARDS, WHEN SERVICING IF IS ESSENTIAL THAT ONLY MANUFACTURERS SPECIFIED PARTS BE USED FOR THE CRITICAL COMPONENTS IN THE SYMBOL MARK OF THE SCHEMATIC.

SECRET
LGElectronics



MODEL	240Hz Back-End Board	DATE	2011. 07. 05
BLOCK	LG1122_DDR3	SHEET	2 / 6

FRC-III AIP for 1.8V

TYP 0.278A
MAX 0.345A

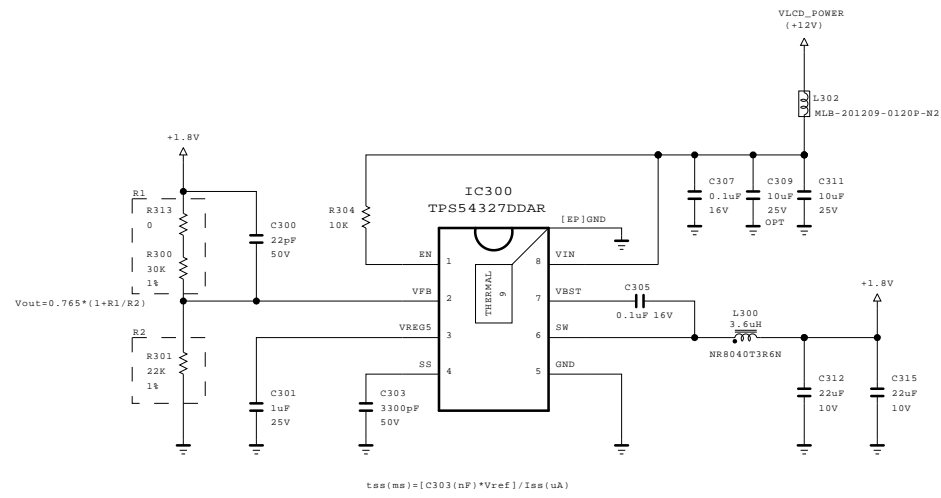

$tss(ms) = [C303(nF) * Vref] / Iss(\mu A)$

FRC-III CORE for 0.9V

TYP 2.521A
MAX 3.124A

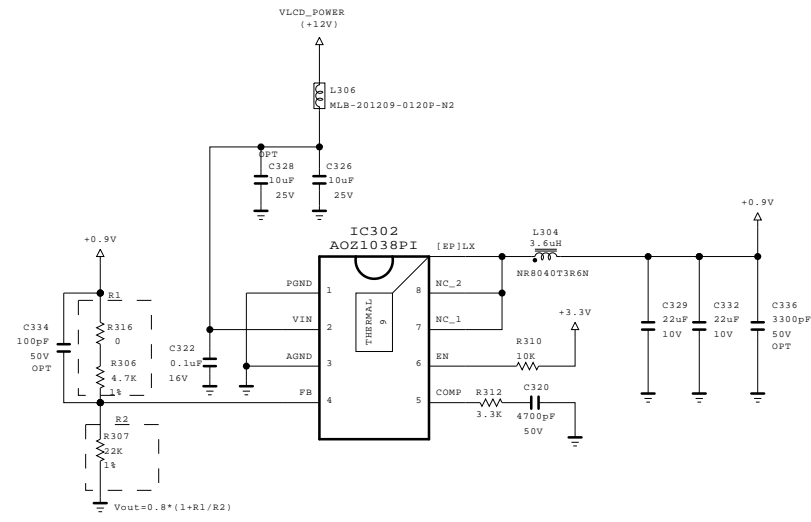

FRC-III DDR3 for 1.5V

TYP 1.149A
MAX 1.184A

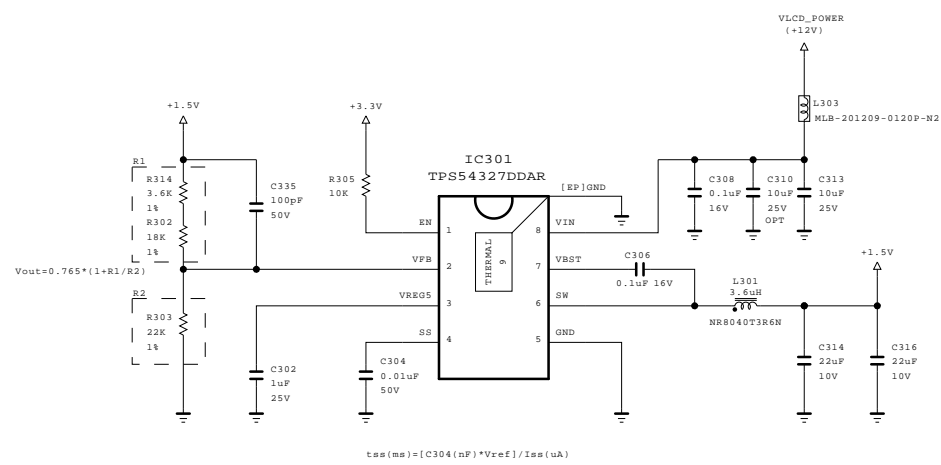

$tss(ms) = [C304(nF) * Vref] / Iss(\mu A)$

FRC-III I/O for 3.3V

TYP 0.043A
MAX 0.046A

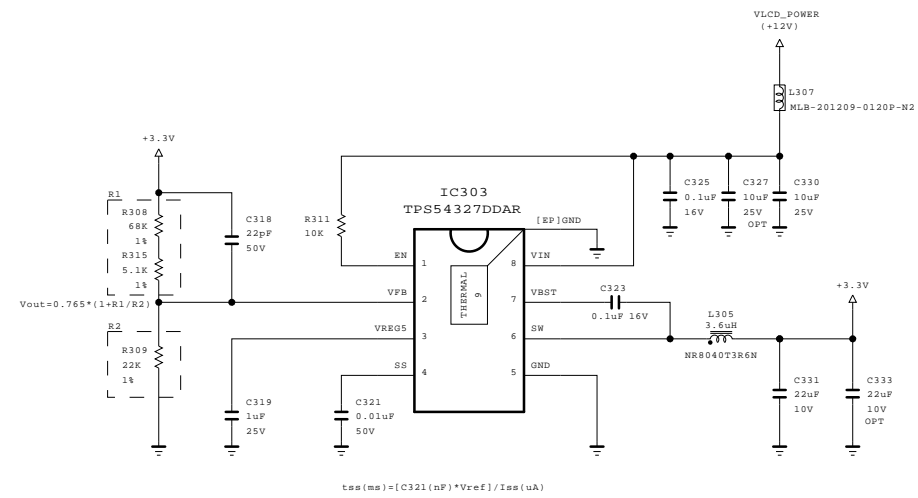

$tss(ms) = [C321(nF) * Vref] / Iss(\mu A)$

LG1122(FRC-III) Power up Sequence

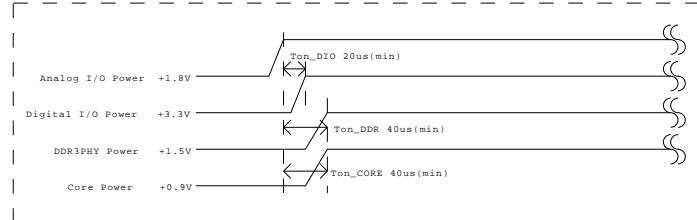

THE Δ SYMBOL MARK OF THIS SCHEMATIC DIAGRAM INCORPORATES SPECIAL FEATURES IMPORTANT FOR PROTECTION FROM X-RADIATION. FILRE AND ELECTRICAL SHOCK HAZARDS, WHEN SERVICING IF IS ESSENTIAL THAT ONLY MANUFACTURES SPECIFIED PARTS BE USED FOR THE CRITICAL COMPONENTS IN THE Δ SYMBOL MARK OF THE SCHEMATIC.

SECRET
LGElectronics



MODEL	120Hz Back-End Board	DATE	2011. 07. 05
BLOCK	POWER	SHEET	3 / 6

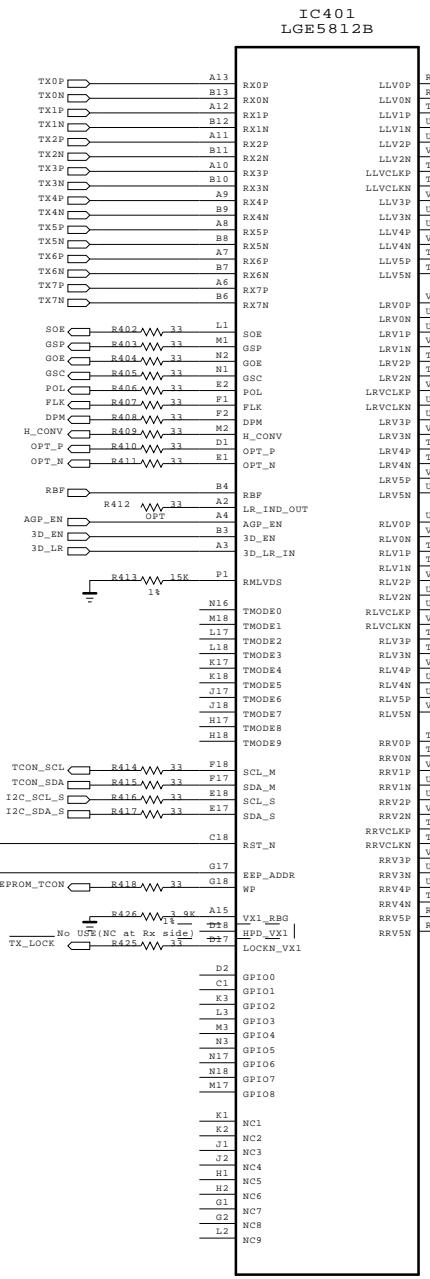

I2C Slave Address : 0x70

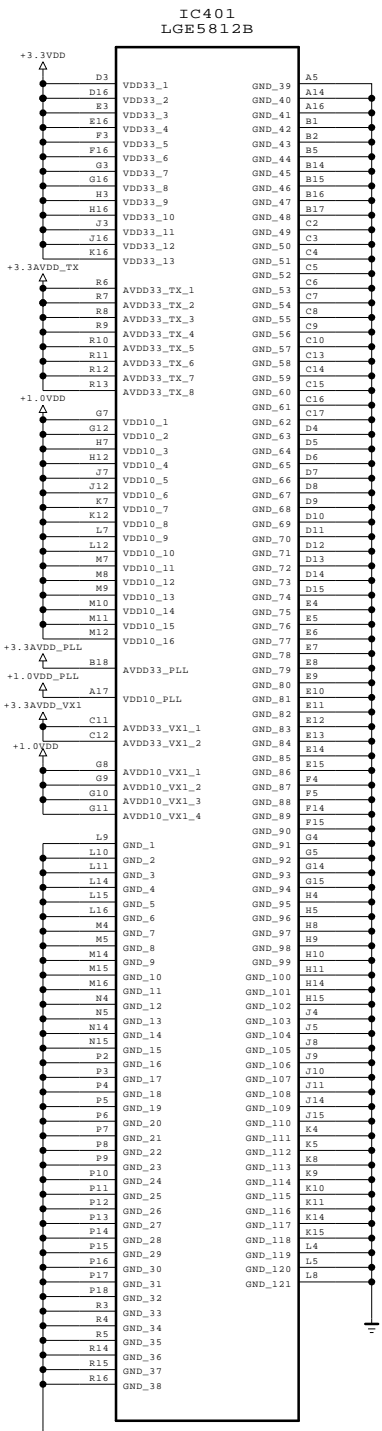
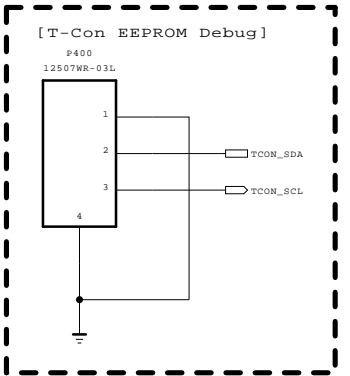
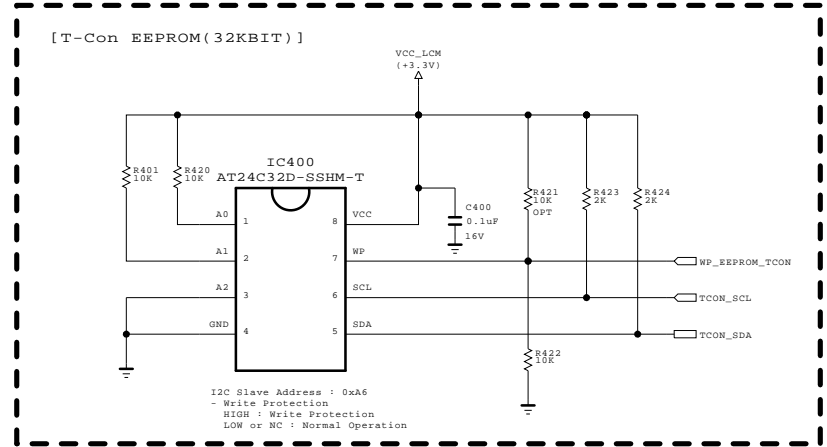

[All of OPT decaps must be placed on PCB Bottom side]

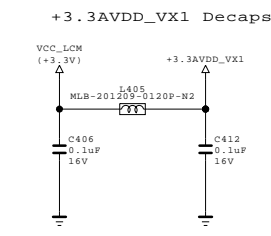
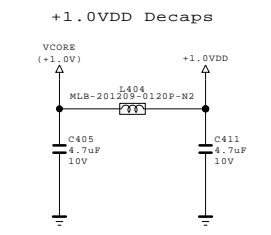
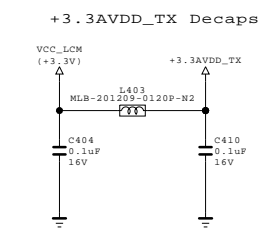
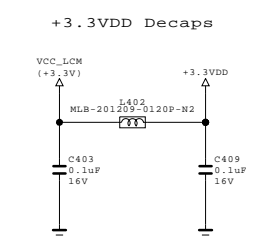
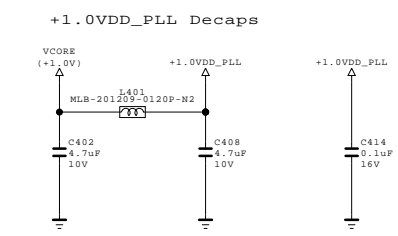
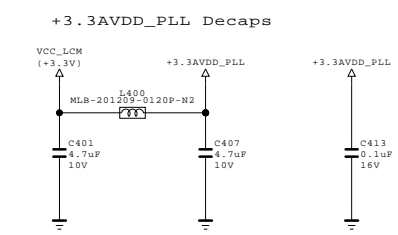

THE Δ SYMBOL MARK OF THIS SCHEMATIC DIAGRAM INCORPORATES SPECIAL FEATURES IMPORTANT FOR PROTECTION FROM X-RADIATION. FILRE AND ELECTRICAL SHOCK HAZARDS, WHEN SERVICING IF IS ESSENTIAL THAT ONLY MANUFACTURERS SPECIFIED PARTS BE USED FOR THE CRITICAL COMPONENTS IN THE Δ SYMBOL MARK OF THE SCHEMATIC.

SECRET
LGElectronics



MODEL	240Hz Back-End Board	DATE	2011. 07. 05
BLOCK	240Hz T-Con(LG5812)	SHEET	4 / 6

[PMIC Block]

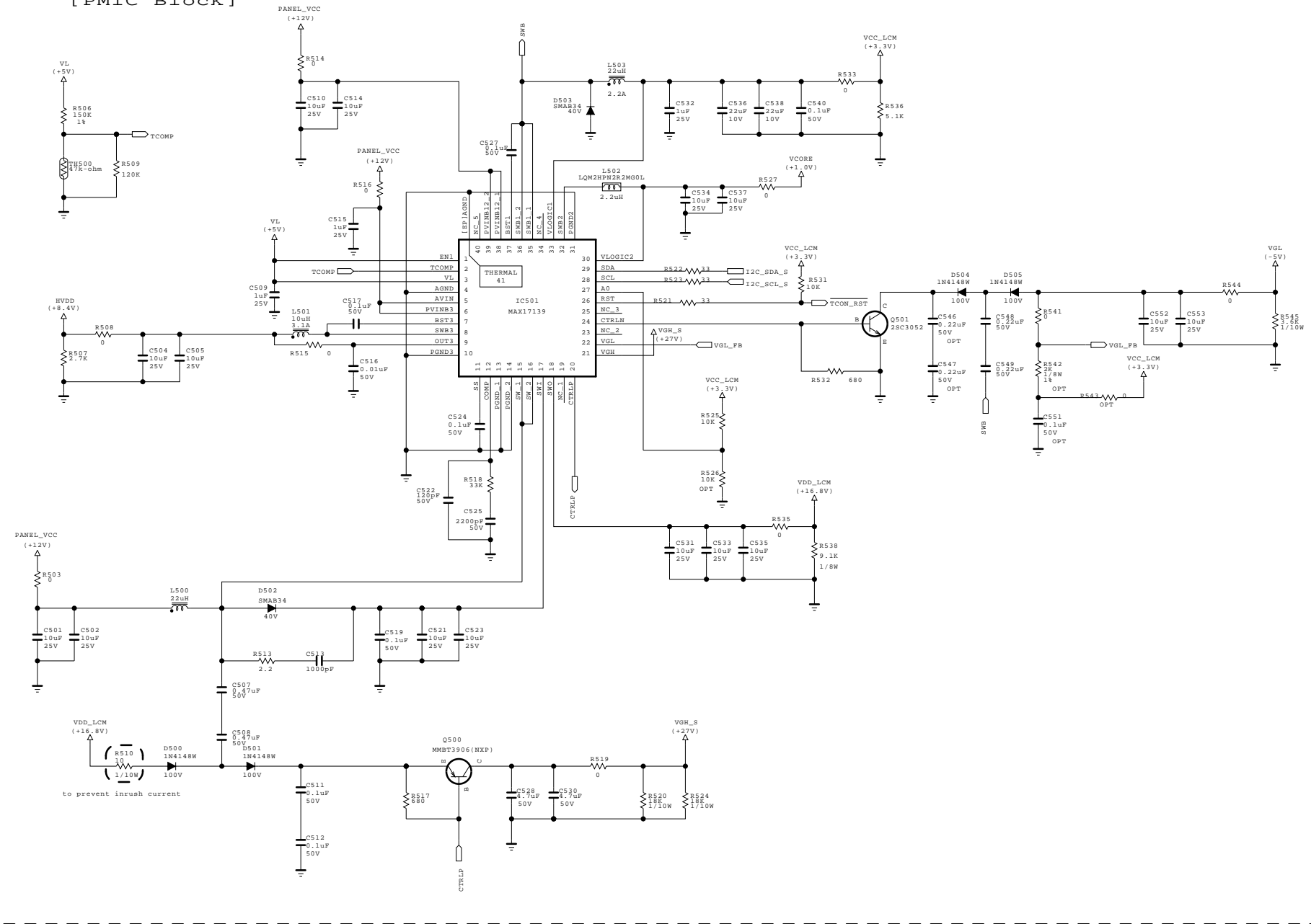

[GPM Block]

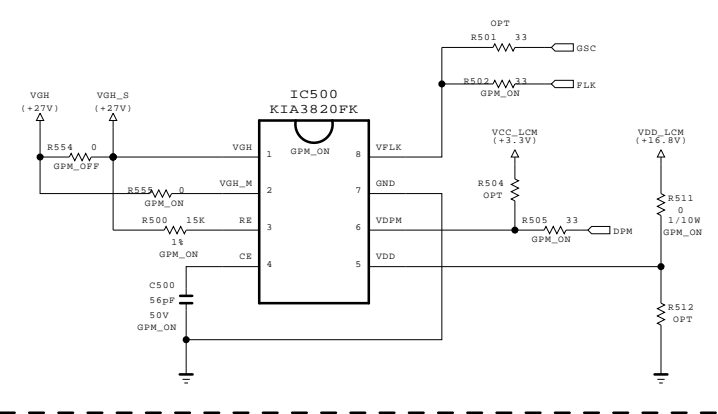

PANEL_POWER

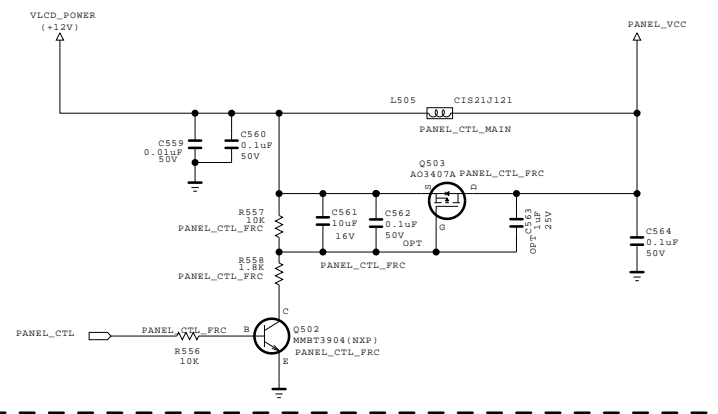

[P-Gamma Block]

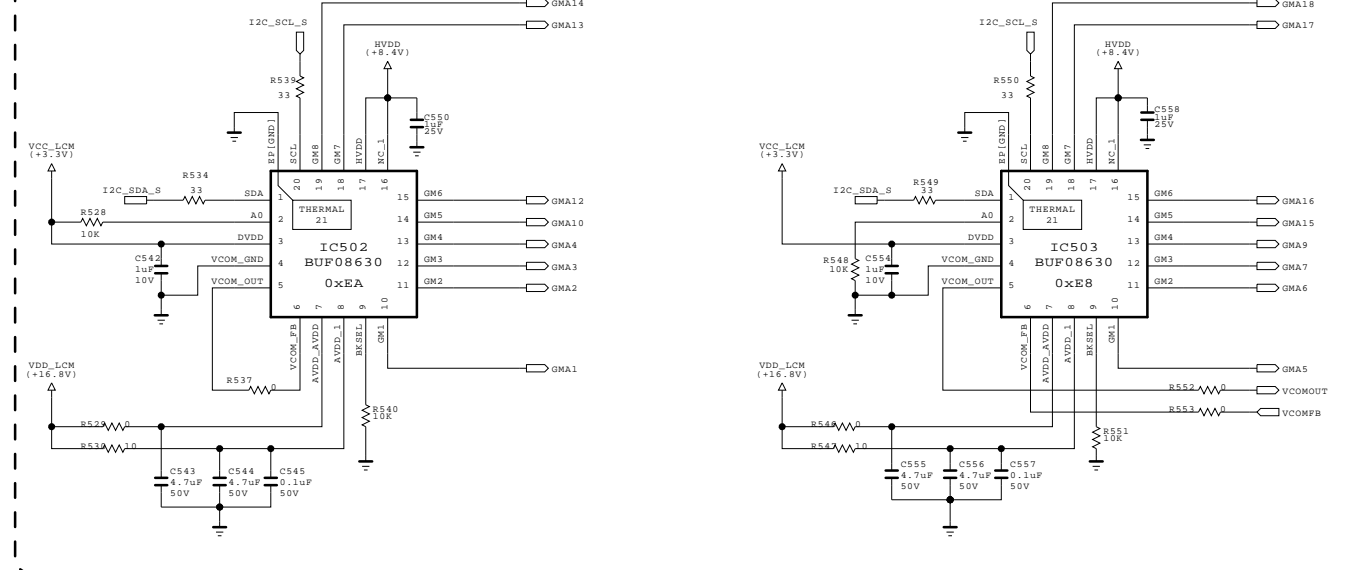

THE SYMBOL MARK OF THIS SCHEMATIC DIAGRAM INCORPORATES SPECIAL FEATURES IMPORTANT FOR PROTECTION FROM X-RADIATION. FILRE AND ELECTRICAL SHOCK HAZARDS, WHEN SERVICING IF IS ESSENTIAL THAT ONLY MANUFACTURES SPECIFIED PARTS BE USED FOR THE CRITICAL COMPONENTS IN THE SYMBOL MARK OF THE SCHEMATIC.

SECRET
LGElectronics



MODEL	240Hz Back-End Board	DATE	2011. 07. 05
BLOCK	PMIC / GAMMA / GPM	SHEET	5 / 6

[80P mini-LVDS output wafer]

[51P HS-LVDS input wafer]

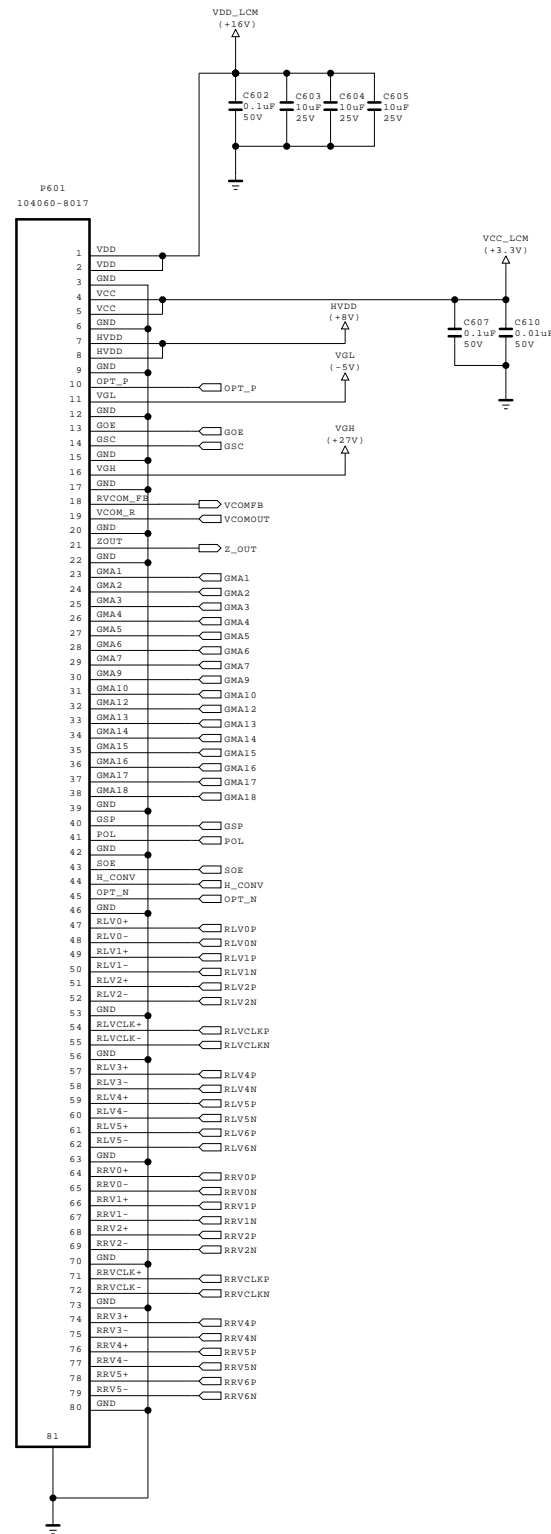
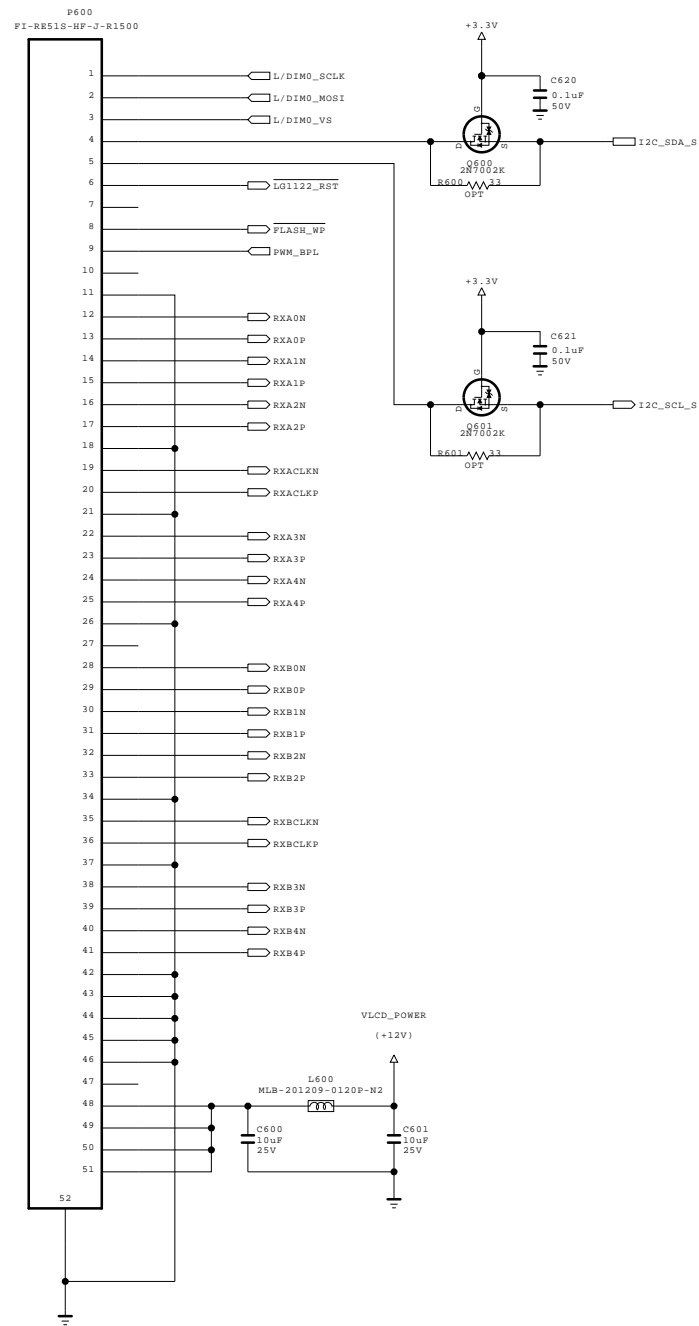

[RIGHT FFC CONNECTOR]

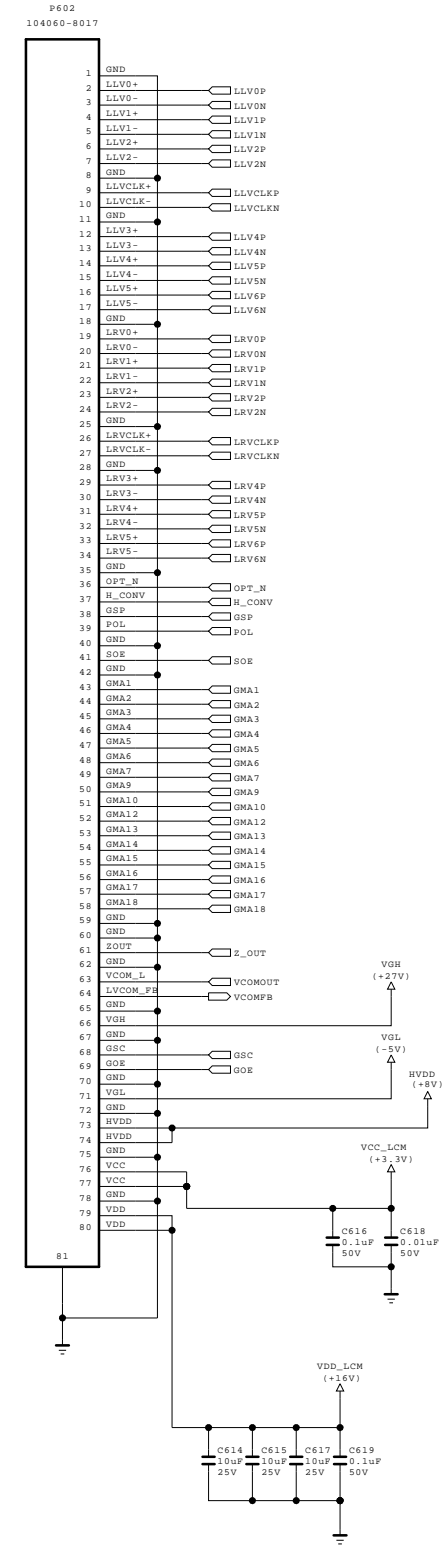

[LEFT FFC CONNECTOR]

THE Δ SYMBOL MARK OF THIS SCHEMATIC DIAGRAM INCORPORATES SPECIAL FEATURES IMPORTANT FOR PROTECTION FROM X-RADIATION. FILRE AND ELECTRICAL SHOCK HAZARDS, WHEN SERVICING IF IS ESSENTIAL THAT ONLY MANUFACTURES SPECIFIED PARTS BE USED FOR THE CRITICAL COMPONENTS IN THE Δ SYMBOL MARK OF THE SCHEMATIC.

SECRET
LGElectronics



MODEL	240Hz Back-End Board	DATE	2011. 07. 05
BLOCK	Wafer	SHEET	6 / 6

Revision History

(0) Proto Design

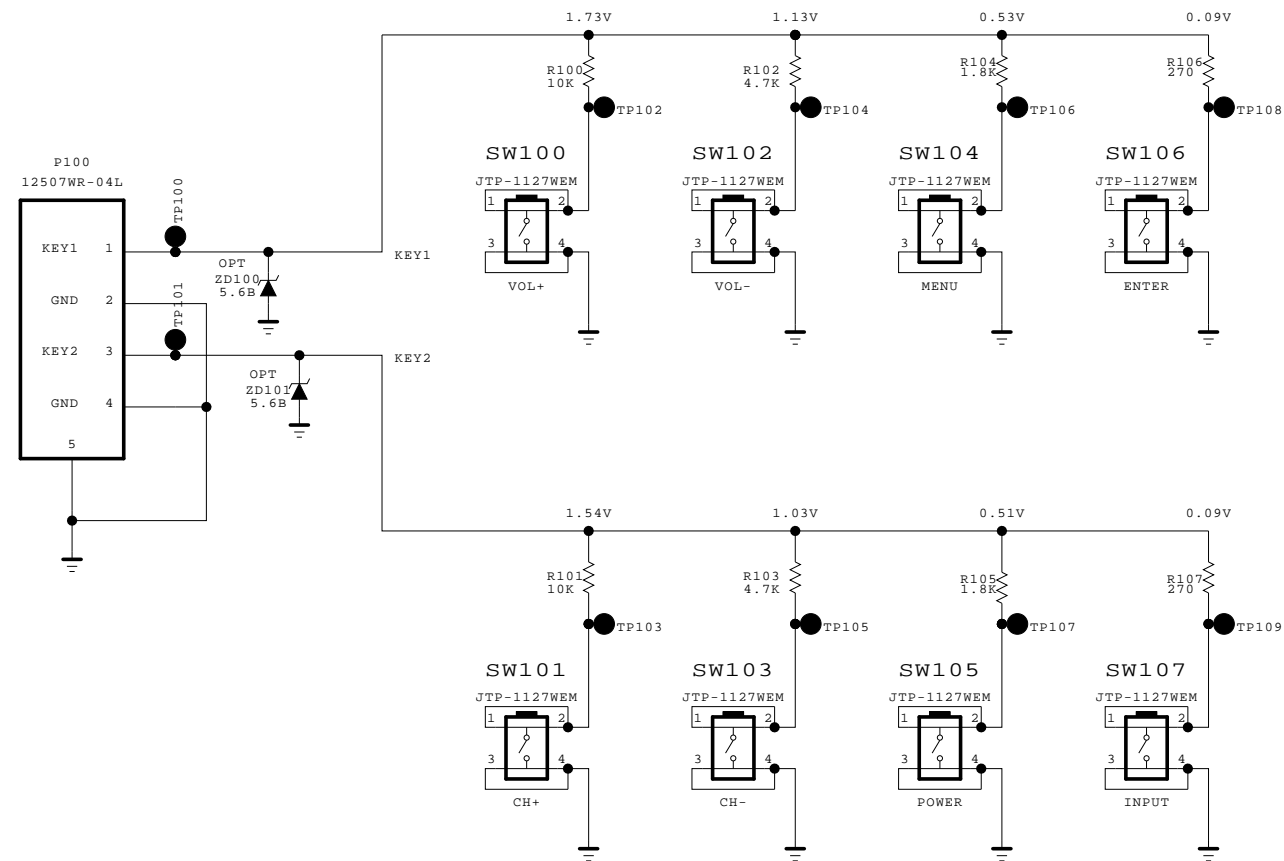

THE SYMBOL MARK OF THIS SCHEMATIC DIAGRAM INCORPORATES SPECIAL FEATURES IMPORTANT FOR PROTECTION FROM X-RADIATION. FILRE AND ELECTRICAL SHOCK HAZARDS, WHEN SERVICING IF IS ESSENTIAL THAT ONLY MANUFACTURES SPECIFIED PARTS BE USED FOR THE CRITICAL COMPONENTS IN THE SYMBOL MARK OF THE SCHEMATIC.

SECRET
LGElectronics

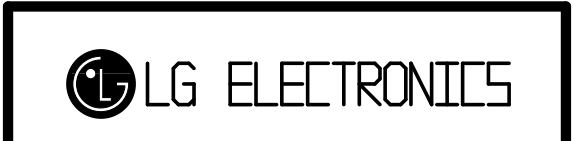

MODEL		DATE	
BLOCK		SHEET	/



LCD TV Repair Guide

`12 years New Models

< Applicable Model >

XXLM960V-ZB

XXLM860V-ZB

V : T2/C/S2

T : T2/C

S : T/C/S2

0 : T/C

2 types of LED - Edge

LED

Benefit: More Clear More Real

LED

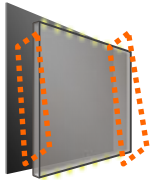

Edge Type w/ Local Dimming

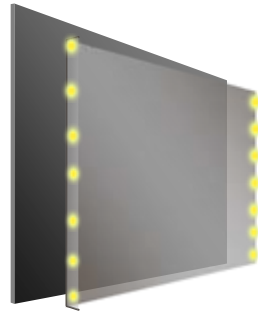
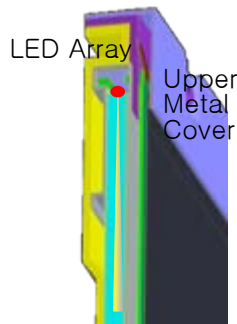
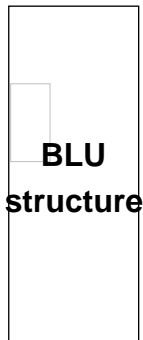

LED Array is on the side of Module

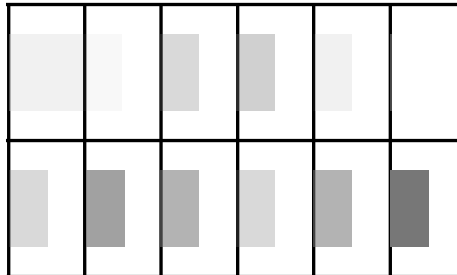
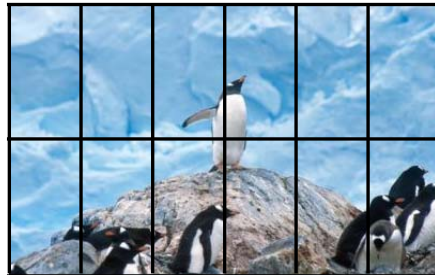

Feature

Edge LED	Best picture quality + thin TV
Local Dimming	Local dimming depicts more deep black.

Model

XXLW750T/W/S/G

42inch : H(2) * V(8) = 16Block

42inch : H(2) * V(8) = 16Block

42inch : H(2) * V(8) = 16Block

2 types of LED - ALEF

LED

Benefit: More Clear More Real

LED



ALEF Type Local Dimming

BLU
structure

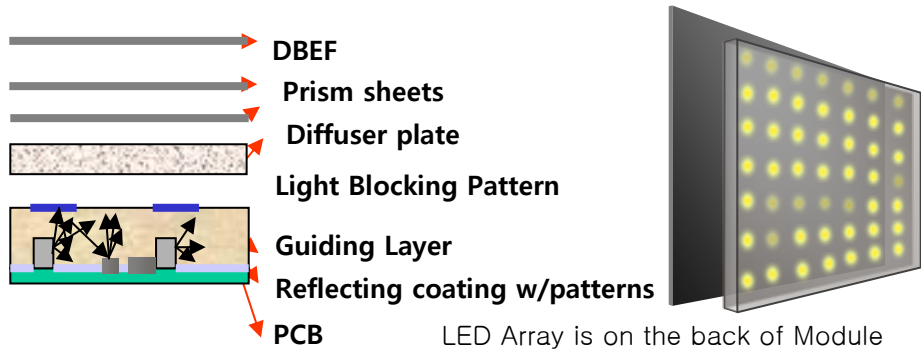

Local
Dimming

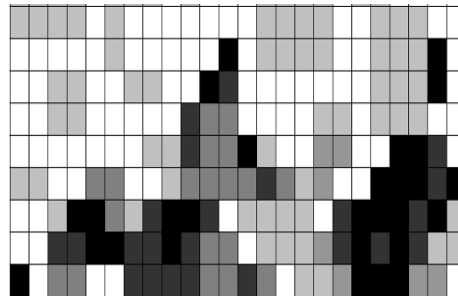
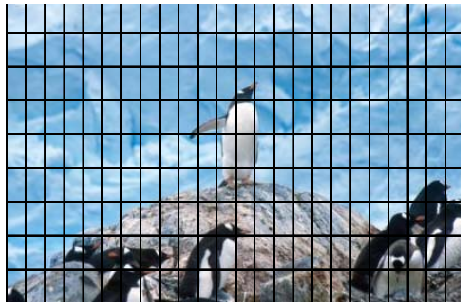

Feature

ALEF LED	Best picture quality + thin TV Slimmer depth better picture quality
Local Dimming	Local dimming depicts more deep black.

Model

XXLM960V

47inch : H(6) * V(4) = 24Block

55inch : H(6) * V(4) = 24Block

XXLM960V-ZB
XXLM860V-ZB

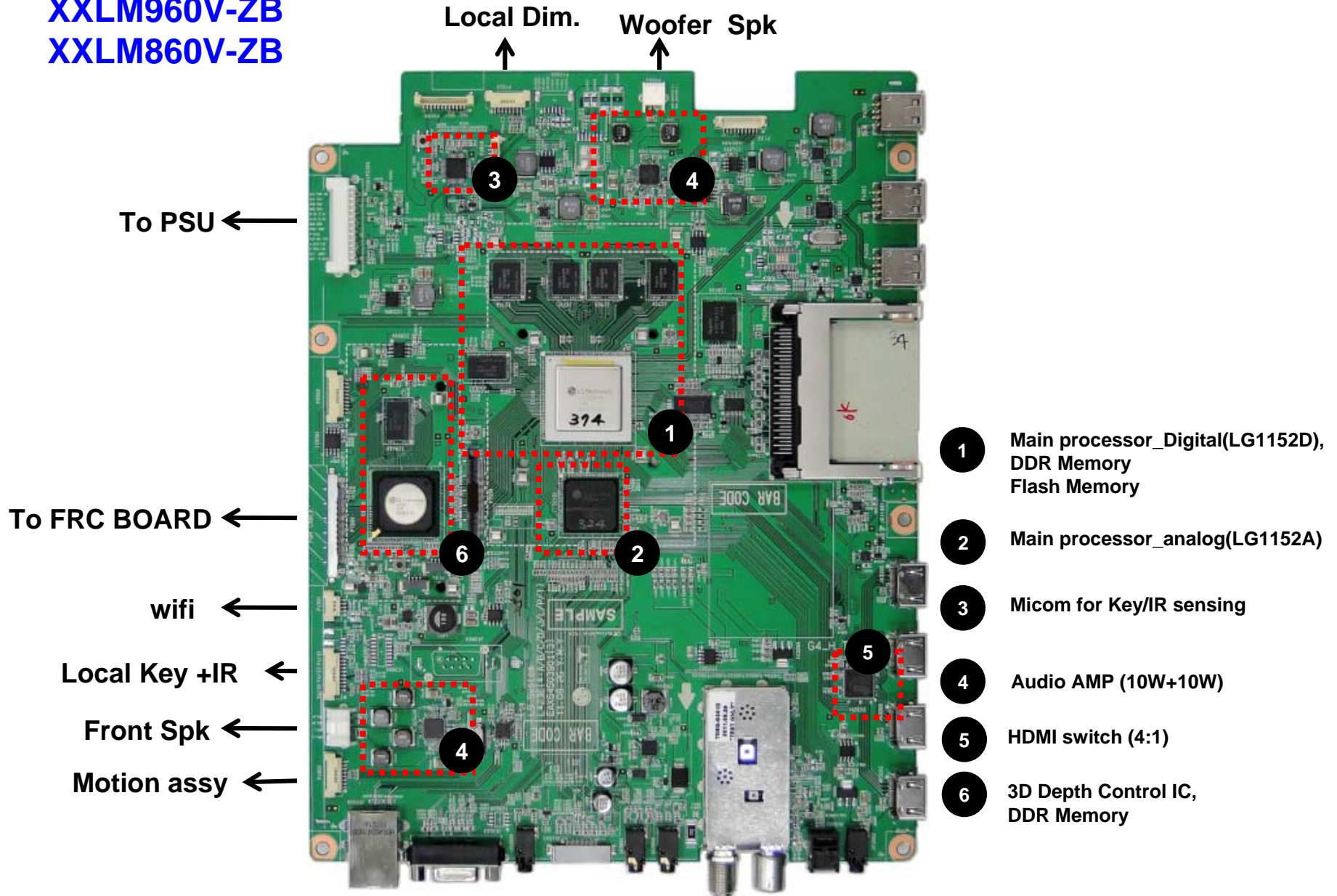

XXLM960V-ZB

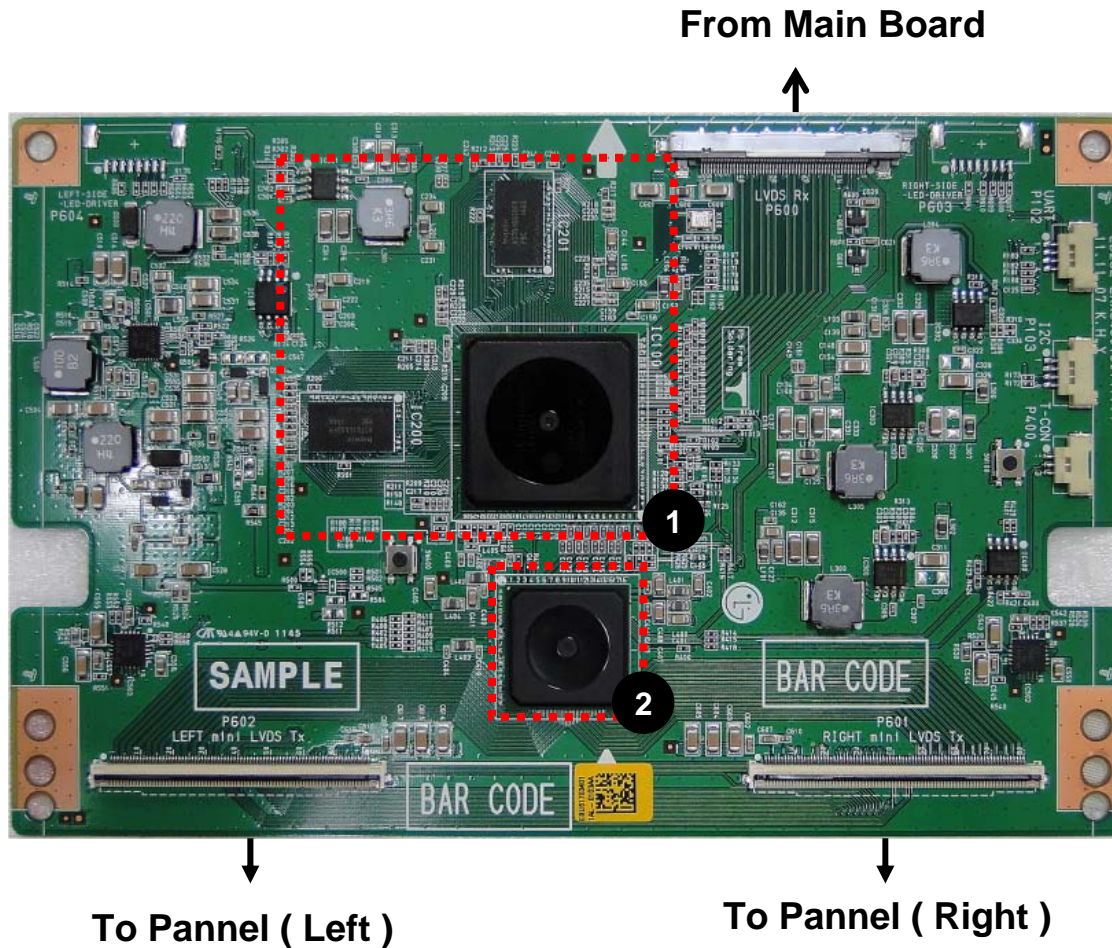

- 1 FRC Processor(LG1122)
- 2 T-Con IC(LG5812)

Block Diagram

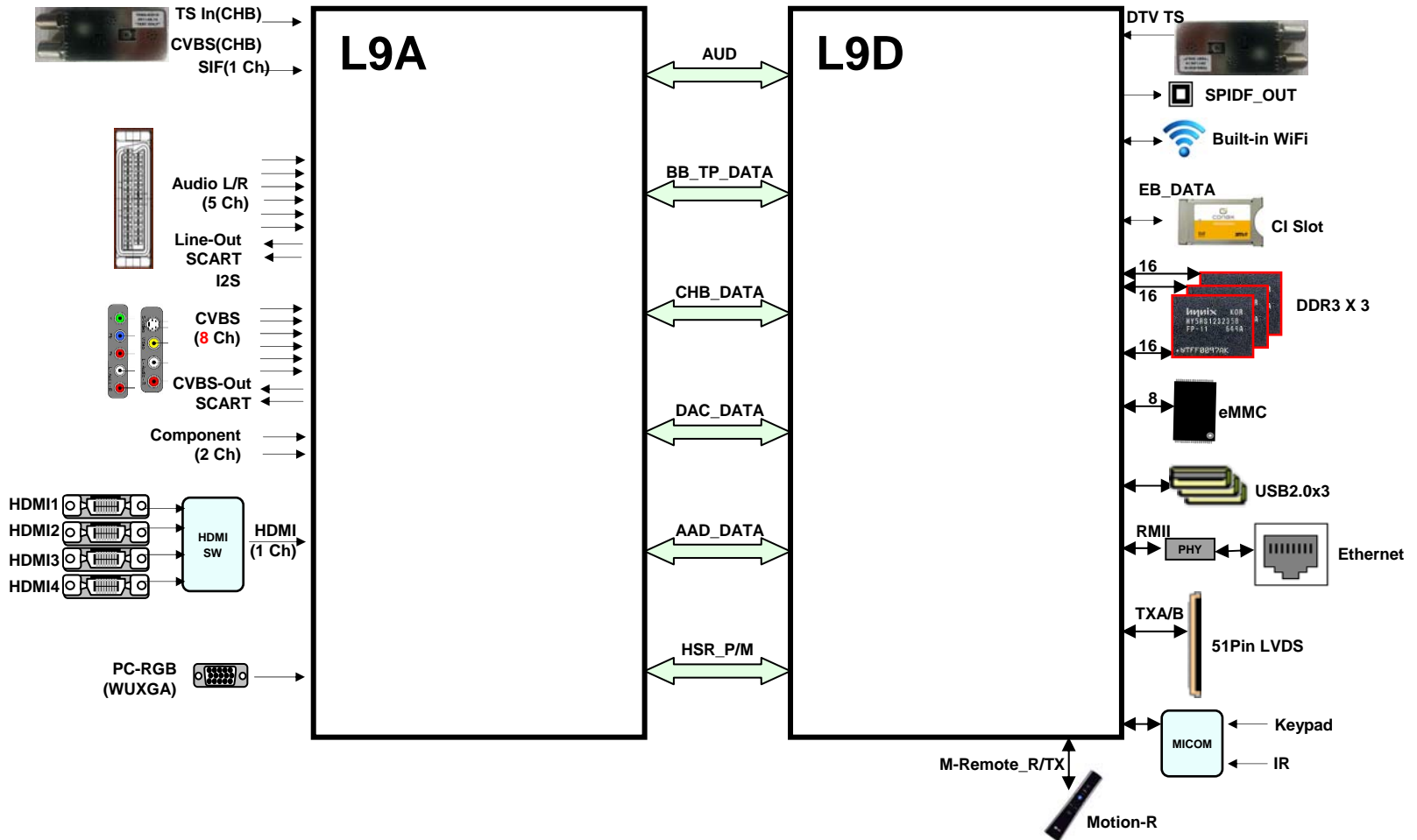

Jack Interface

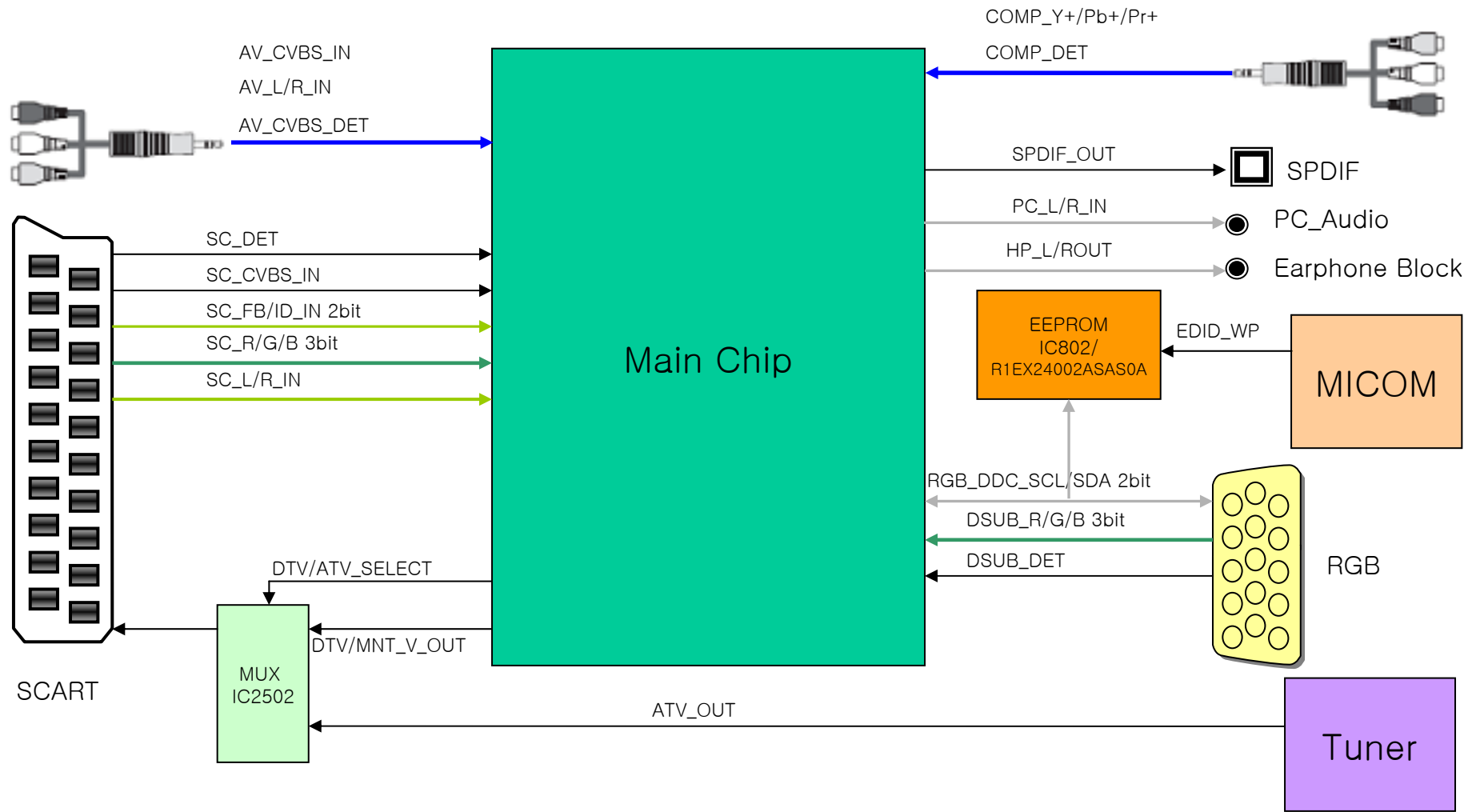

L9 Block diagram

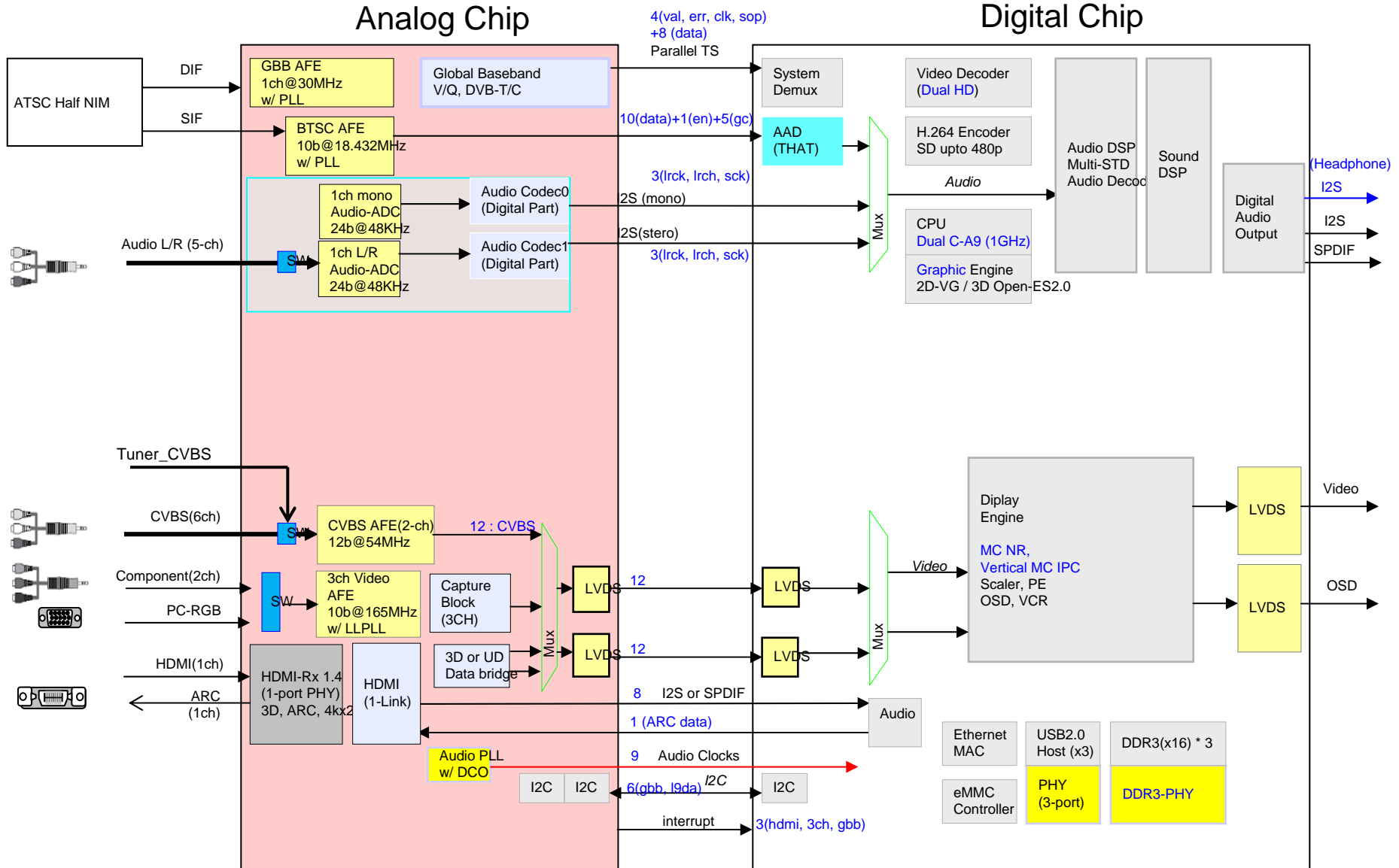

L9 Block diagram

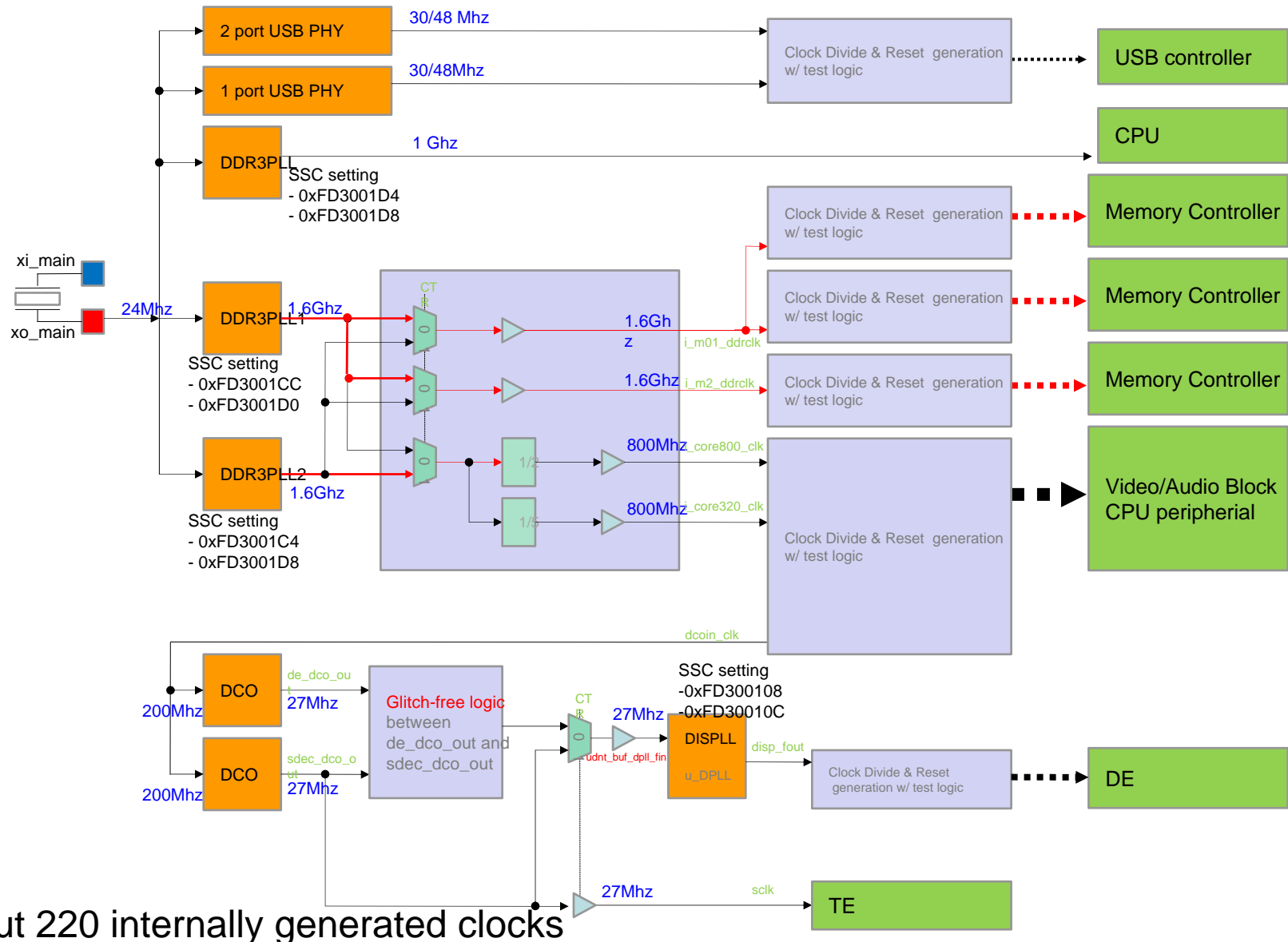

About 220 internally generated clocks

Appendix. Block Diagram for Edge/ALEF Backlight

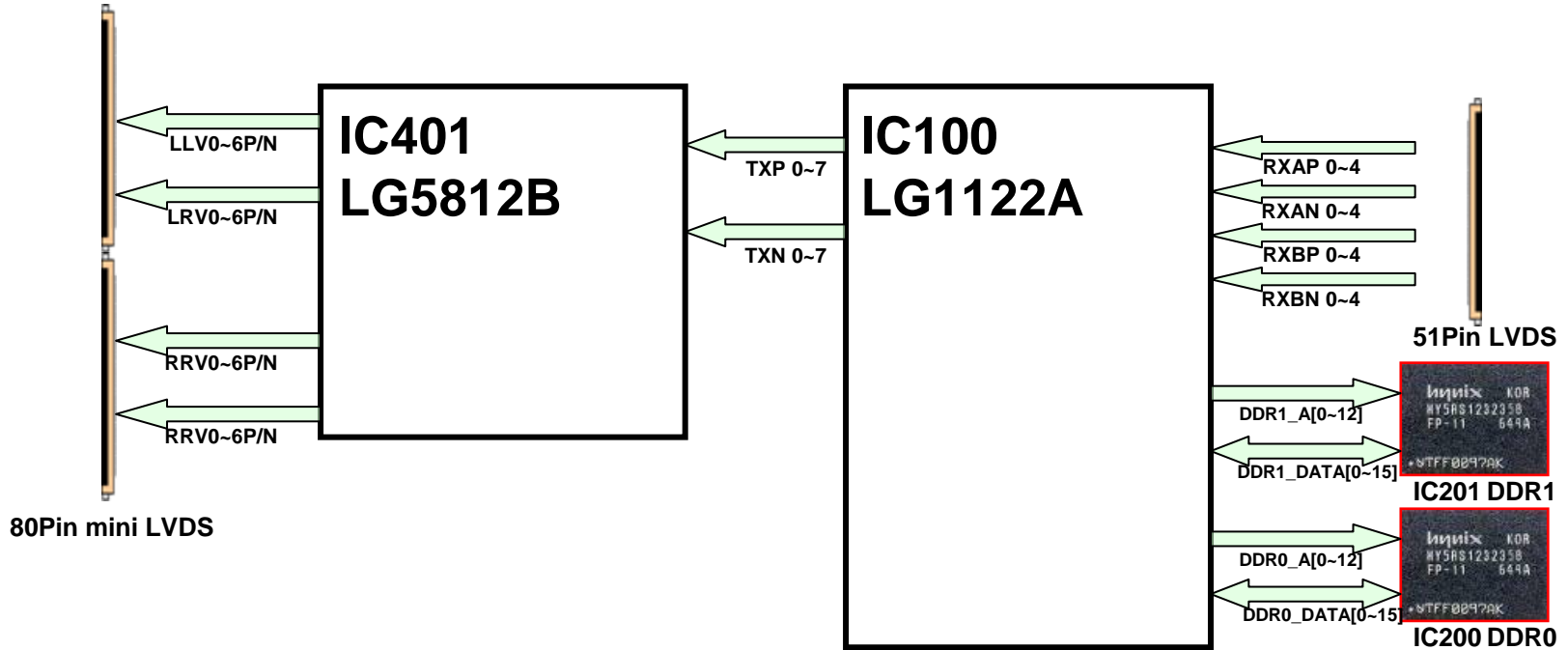
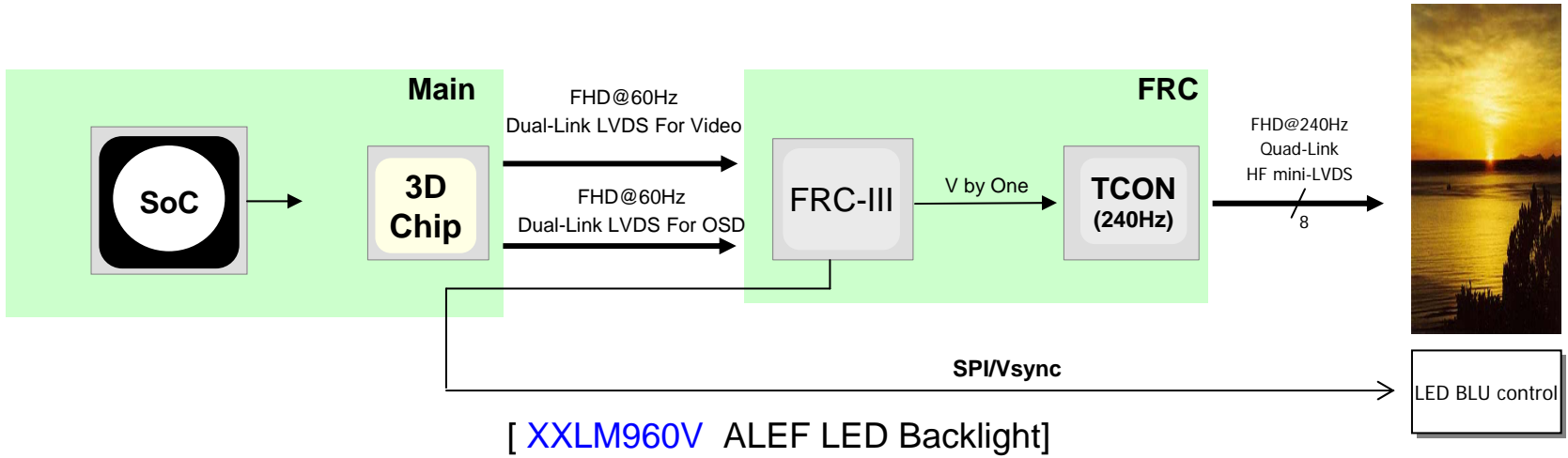

Interconnection - 1

XXLM960V-ZB

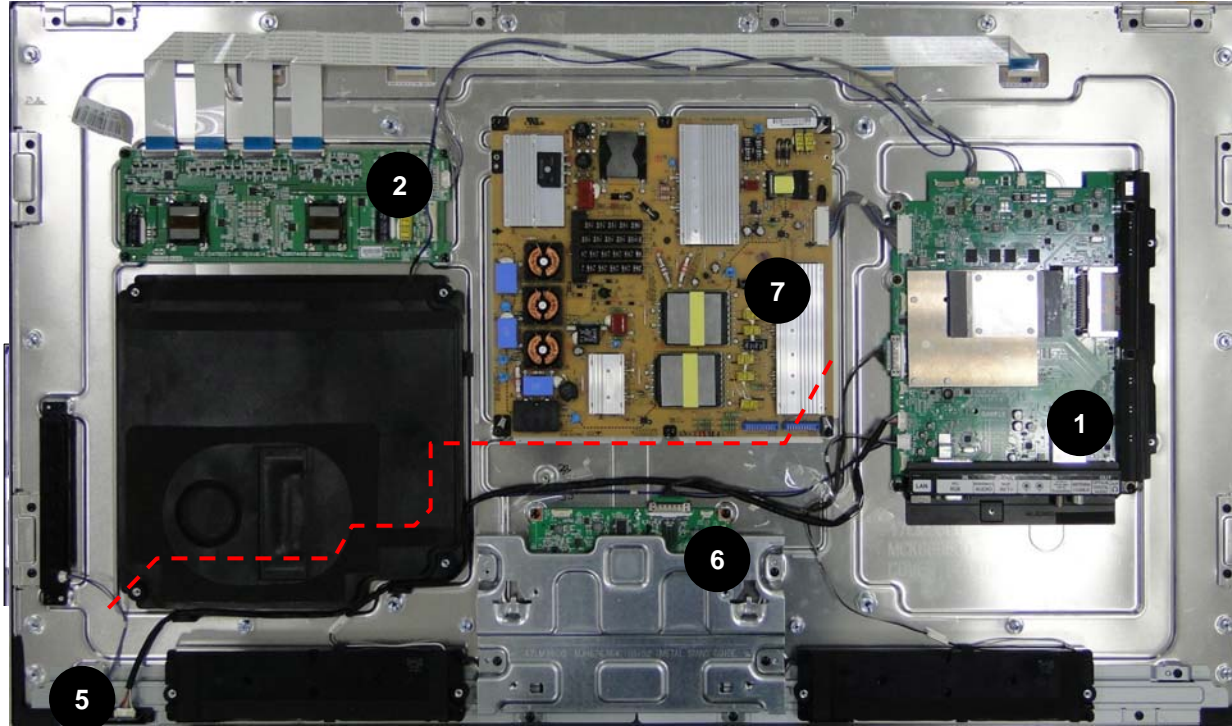

[PCBs]

- ① Main PCB
- ② LED driver
- ③ WIFI ASSY
- ④ RF MOTION ASSY
- ⑤ IR Key PCB
- ⑥ FRC ASSY
- ⑦ PSU



Interconnection – sub PCB(XXLM960V Series)

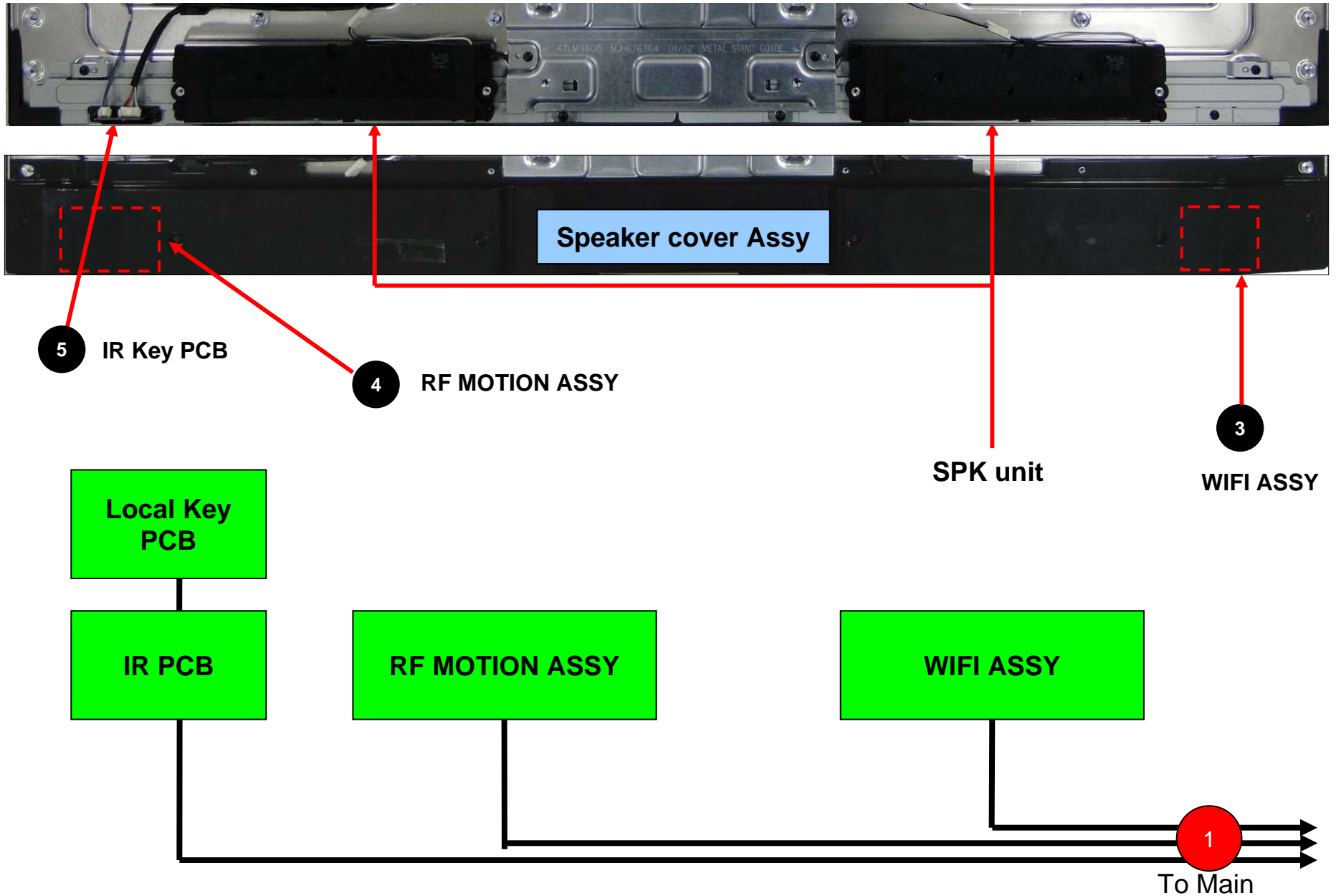

Contents of LCD TV Standard Repair Process

No.	Error symptom (High category)	Error symptom (Mid category)	Page	Remarks
1	A. Video error	No video/Normal audio	1	
2		No video/No audio	2	
3		Picture broken/ Freezing	3	
4		Color error	4	
5		Vertical/Horizontal bar, residual image, light spot, external device color error	5	
6	B. Power error	No power	6	
7		Off when on, off while viewing, power auto on/off	7	
8	C. Audio error	No audio/Normal video	8	
9		Wrecked audio/discontinuation/noise	9	
10	D. Function error	Remote control & Local switch checking	10	
11		M4 operating checking	11	
12		Wifi operating checking	12	
13		External device recognition error	13	
14	E. Noise	Circuit noise, mechanical noise	14	
15	F. Exterior error	Exterior defect	15	

First of all, Check whether there is SVC Bulletin in GCSC System for these model.

LCD TV	Error symptom	A. Video error	Established date	2012.01.16	
		No video/ Normal audio	Revised date		1/15

**First of all, Check whether all of cables between board is inserted properly or not.
(Main B/D↔ Power B/D, LVDS Cable,Speaker Cable,IR B/D Cable,,)**

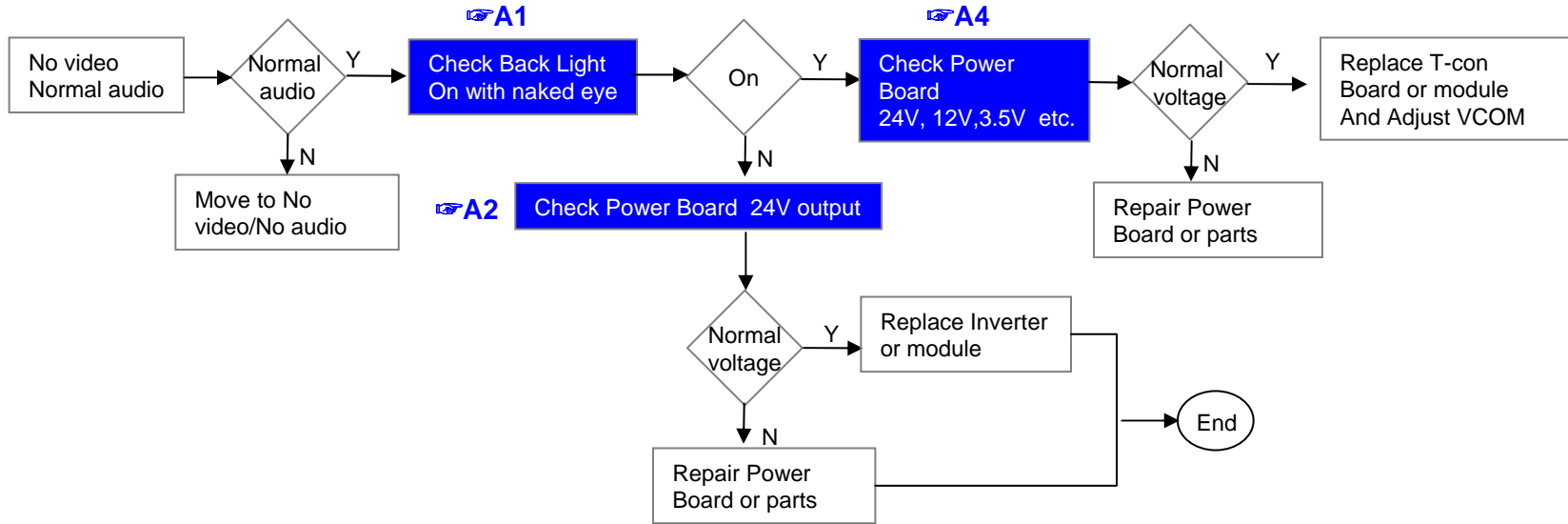

※ Precaution A7 & A3



LCD TV

Error
symptom

A. Video error

Established
date

2012.01.16

No video/ No audio

Revised date

2/15

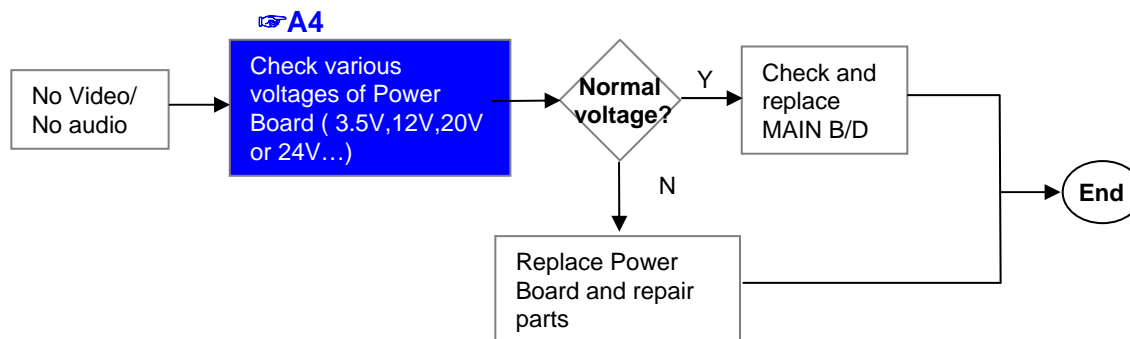

LCD TV	Error symptom	A. Video error	Established date	2012.01.16	
		Picture broken/ Freezing	Revised date		3/15

A6

Check RF Signal level

- . By using Digital signal level meter
- . By using Diagnostics menu on OSD
(Setting → Set up → Manual Tuning → Check the Signal)
- Signal strength (Normal : over 50%)
- Signal Quality (Normal: over 50%)

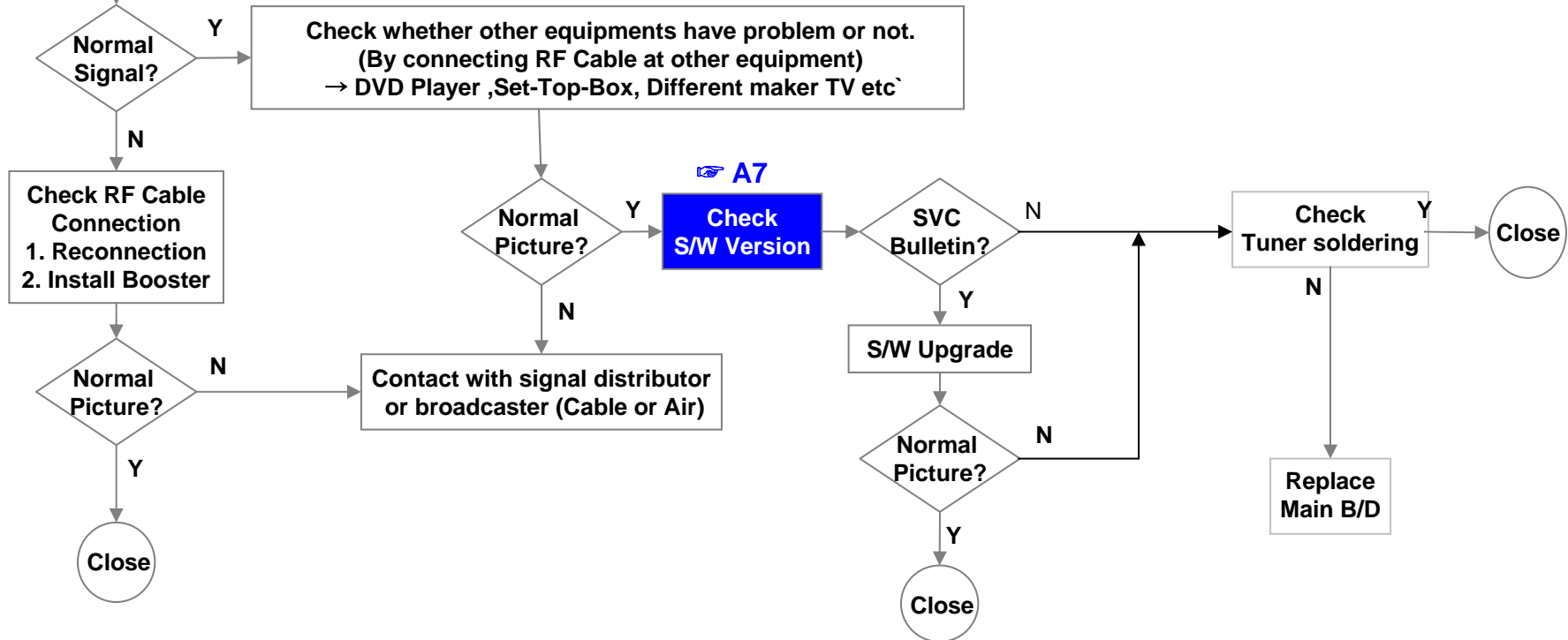

LCD TV	Error symptom	A. Video error	Established date	2012.01.16	
		Color error	Revised date		4/15

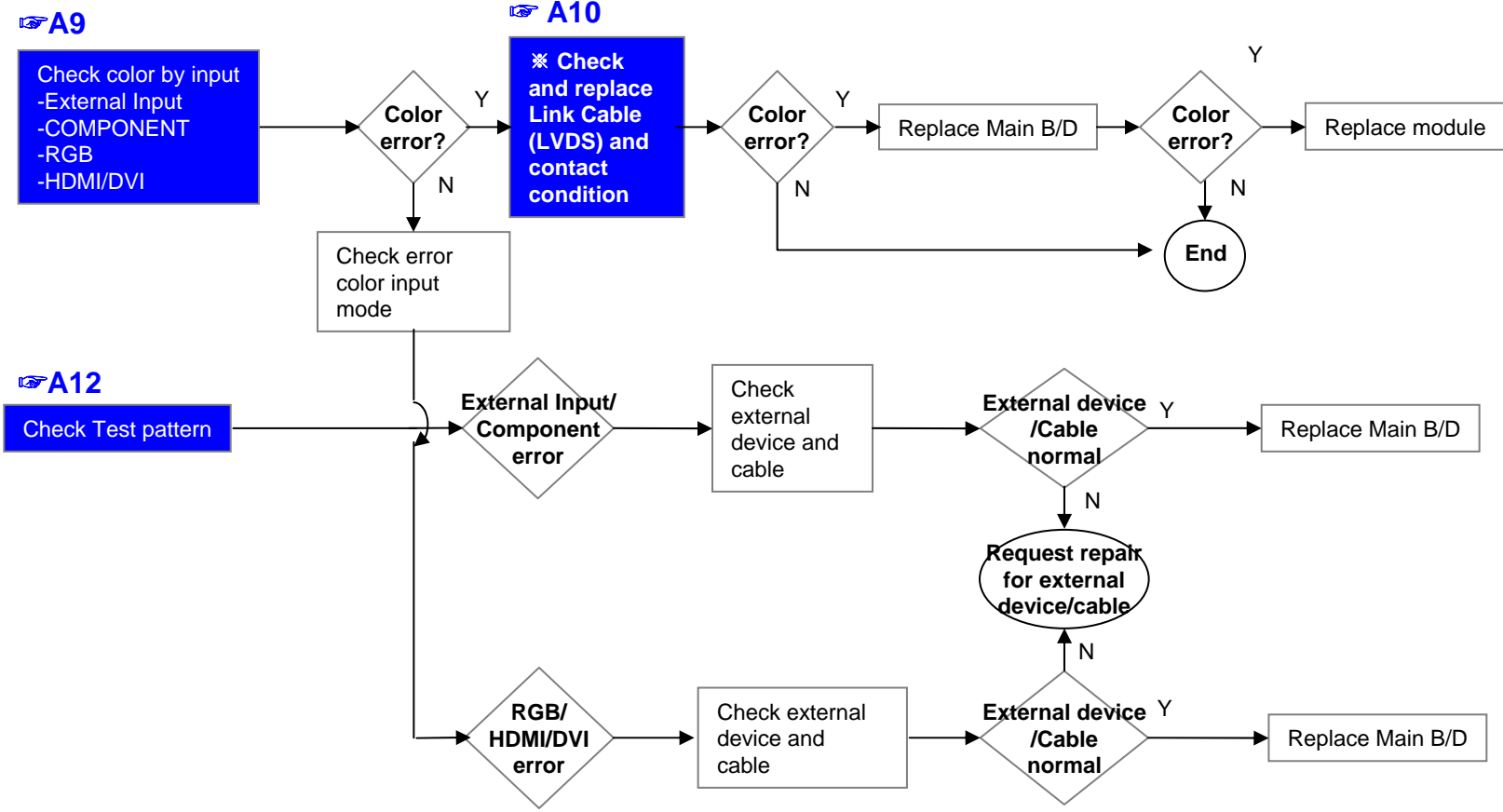

LCD TV	Error symptom	A. Video error	Established date	2012.01.16	
		Vertical / Horizontal bar, residual image, light spot, external device color error	Revised date		5/15

Vertical/Horizontal bar, residual image, light spot

A9

Check color condition by input
 -External Input
 -Component
 -RGB
 -HDMI/DVI

A12

Check Test pattern

A10

Check and replace Link Cable

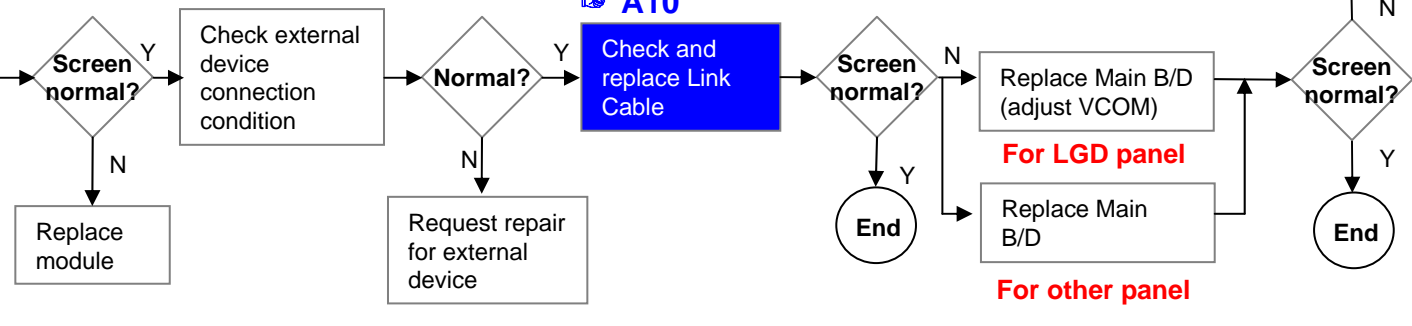

External device screen error-Color error

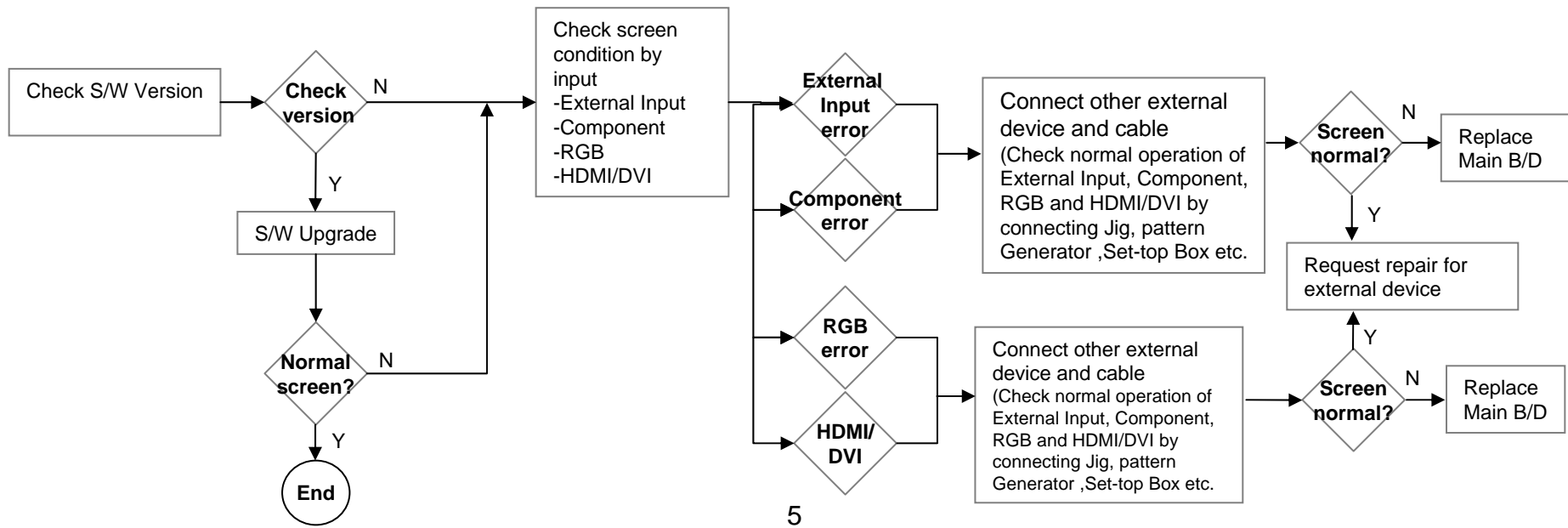

LCD TV	Error symptom	B. Power error	Established date	2012.01.16	
		No power	Revised date		6/15

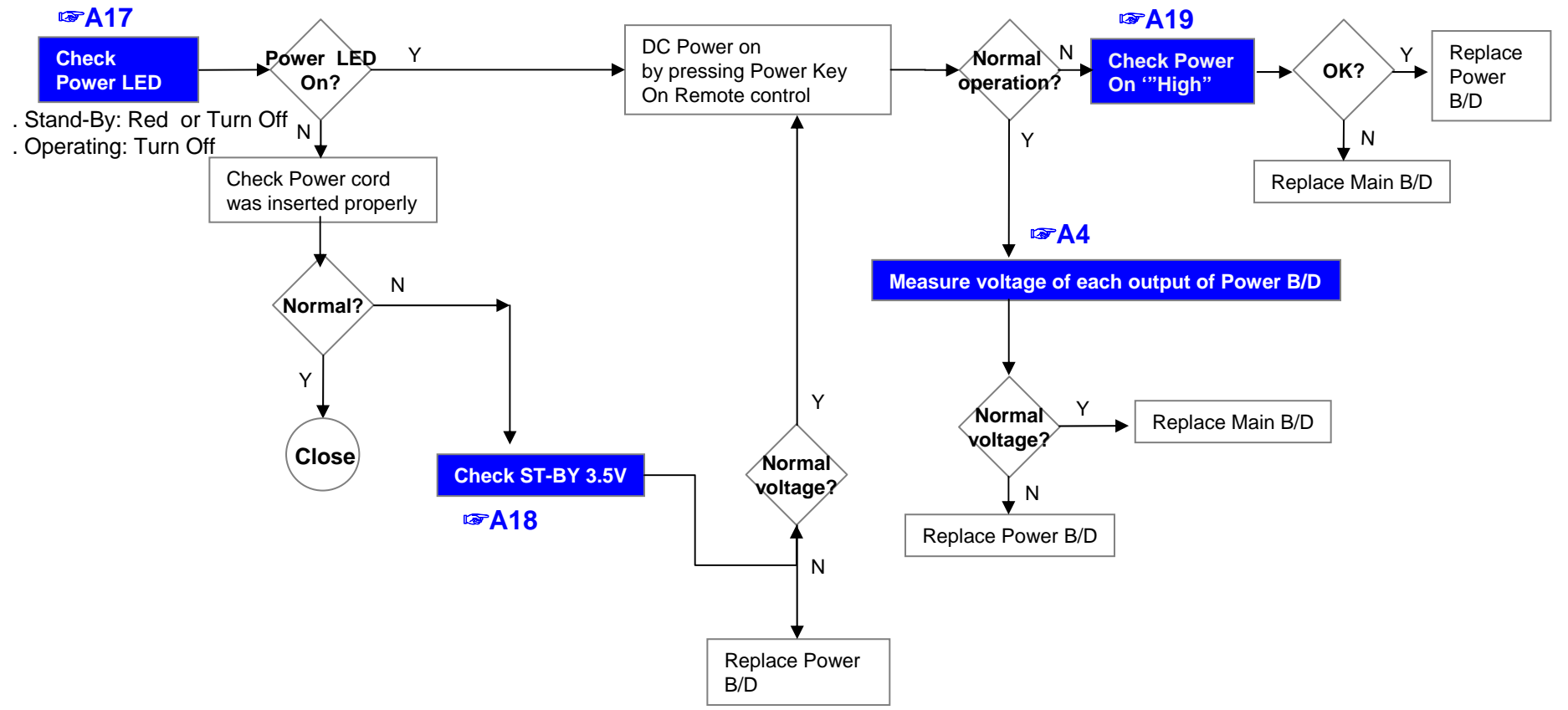

LCD TV	Error symptom	B. Power error	Established date	2012.01.16	
		Off when on, off while viewing, power auto on/off	Revised date		7/15

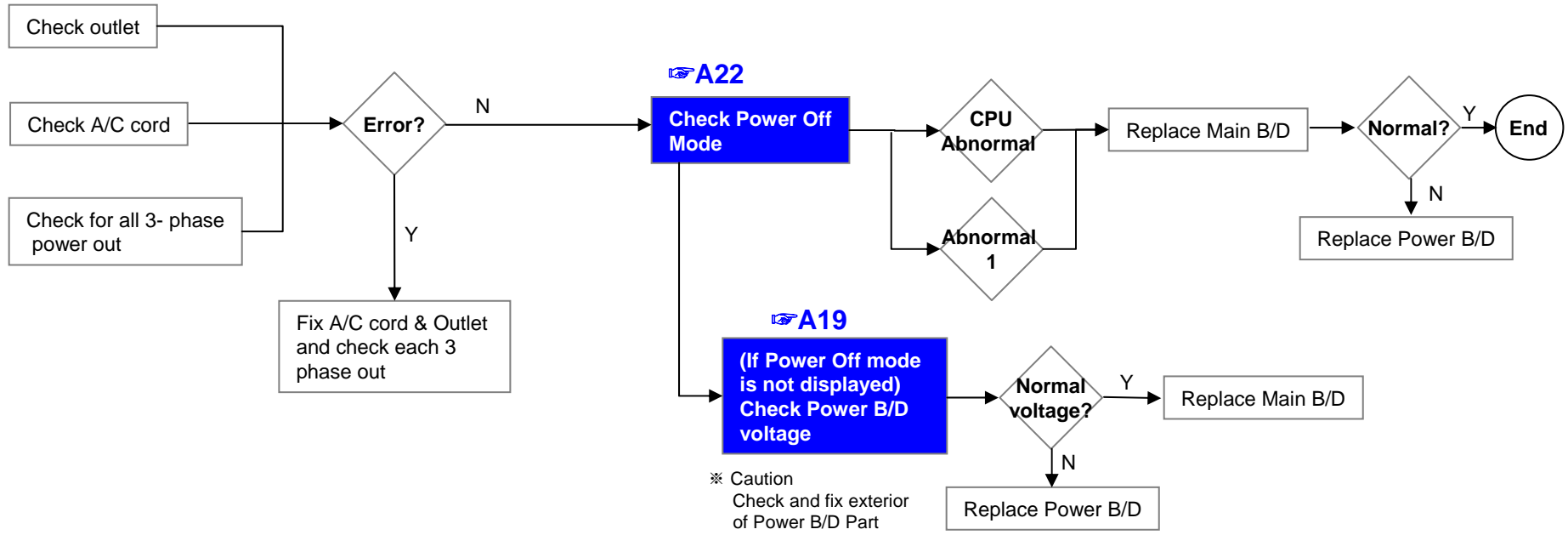

* Please refer to the all cases which can be displayed on power off mode.

Status	Power off List	Explanation
Normal	"POWEROFF_REMOTEKEY"	Power off by REMOTE CONTROL
	"POWEROFF_OFFTIMER"	Power off by OFF TIMER
	"POWEROFF_SLEEPTIMER"	Power off by SLEEP TIMER
	"POWEROFF_INSTOP"	Power off by INSTOP KEY
	"POWEROFF_AUTOOFF"	Power off by AUTO OFF
	"POWEROFF_ONTIMER"	Power off by ON TIMER
	"POWEROFF_RS232C"	Power off by RS232C
	"POWEROFF_RESREC"	Power off by Reserved Record
	"POWEROFF_RECEND"	Power off by End of Recording
	"POWEROFF_SWDOWN"	Power off by S/W Download
	"POWEROFF_UNKNOWN"	Power off by unknown status except listed case
Abnormal	"POWEROFF_ABNORMAL1"	Power off by abnormal status except CPU trouble
	"POWEROFF_CPUABNORMAL"	Power off by CPU Abnormal

LCD TV	Error symptom	C. Audio error	Established date	2012.01.16	
		No audio/ Normal video	Revised date		8/15

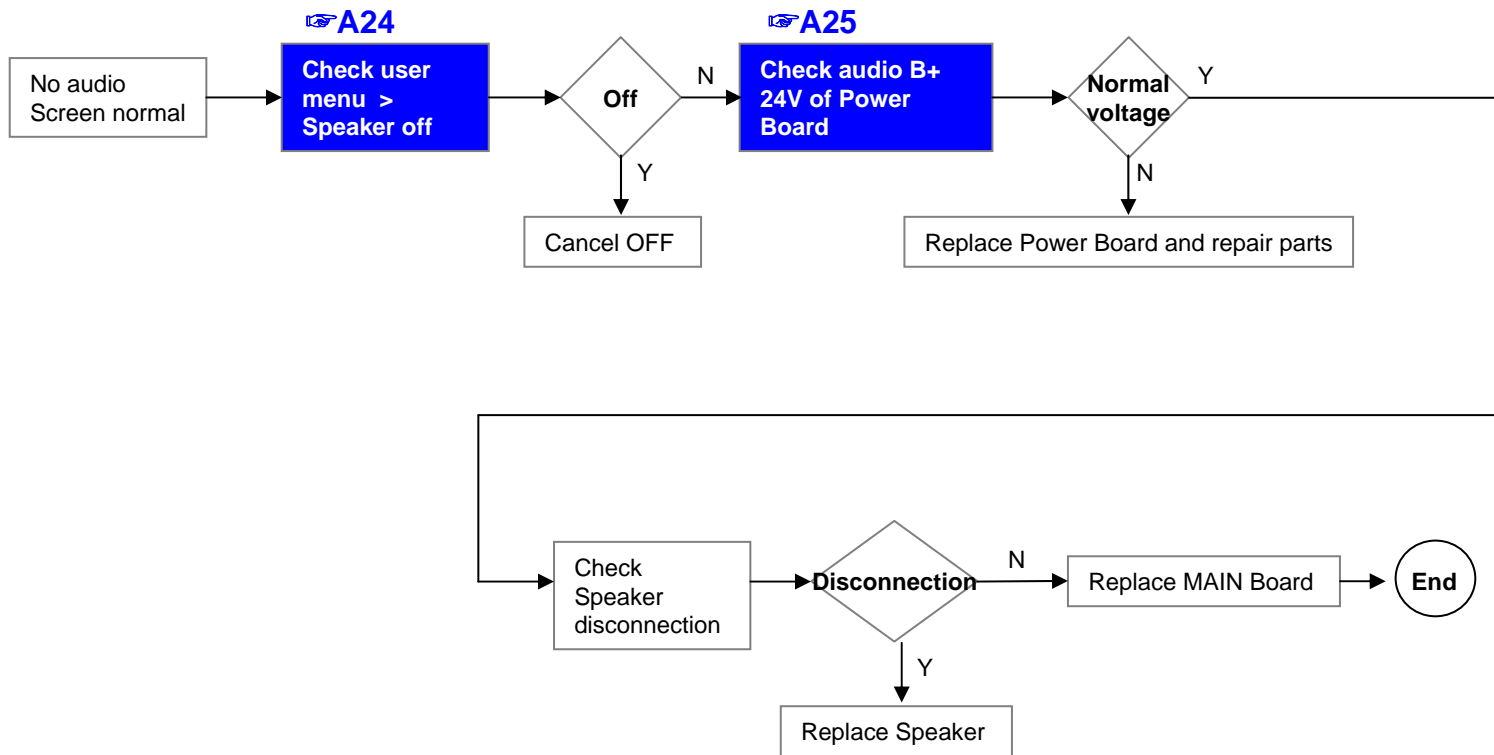

LCD TV	Error symptom	C. Audio error	Established date	2012.01.16	
		Wrecked audio/ discontinuation/noise	Revised date		9/15

→ abnormal audio/discontinuation/noise is same after “Check input signal” compared to No audio

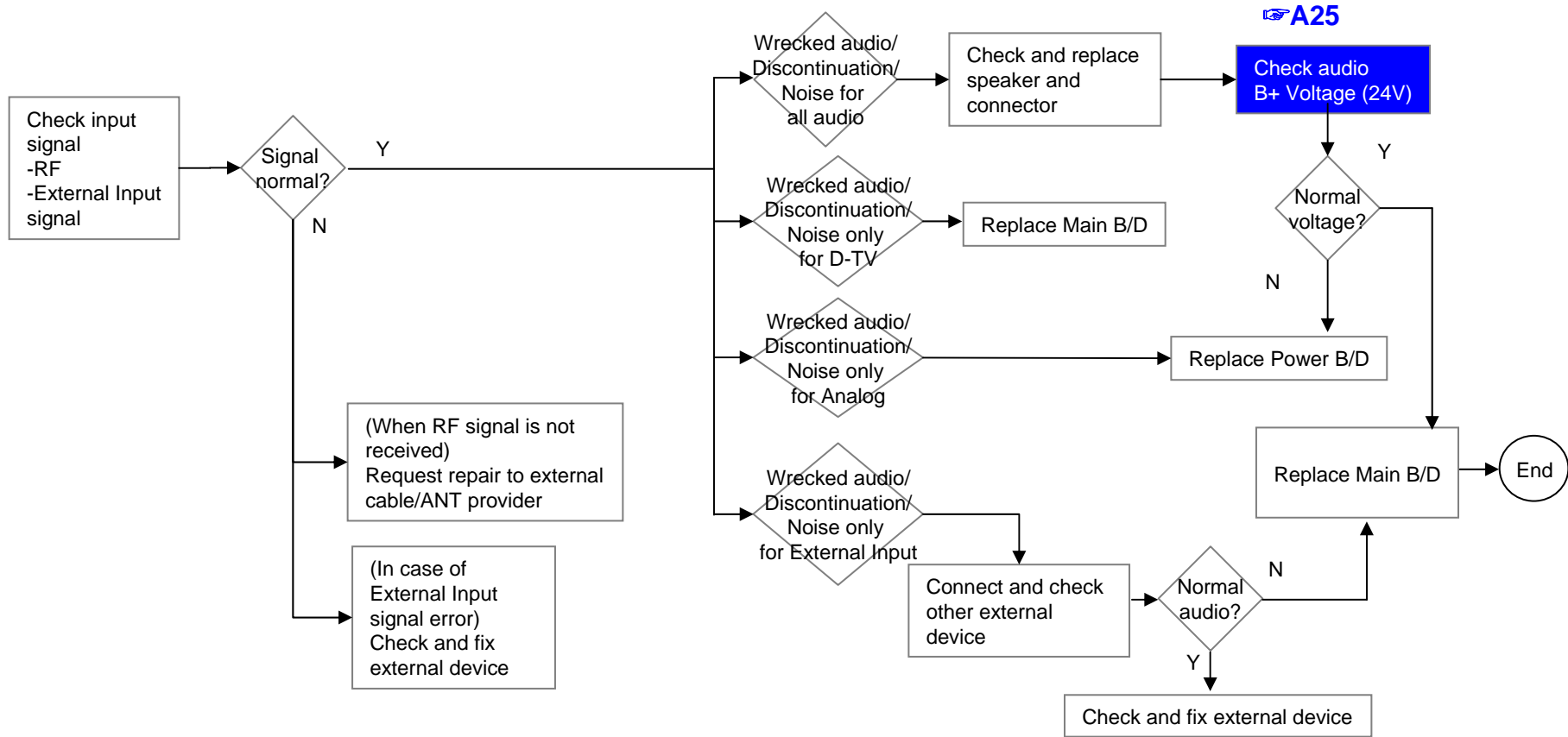

LCD TV	Error symptom	D. Function error	Established date	2012.01.16	
		Remote control & Local switch checking	Revised date		10/15

1. Remote control(R/C) operating error

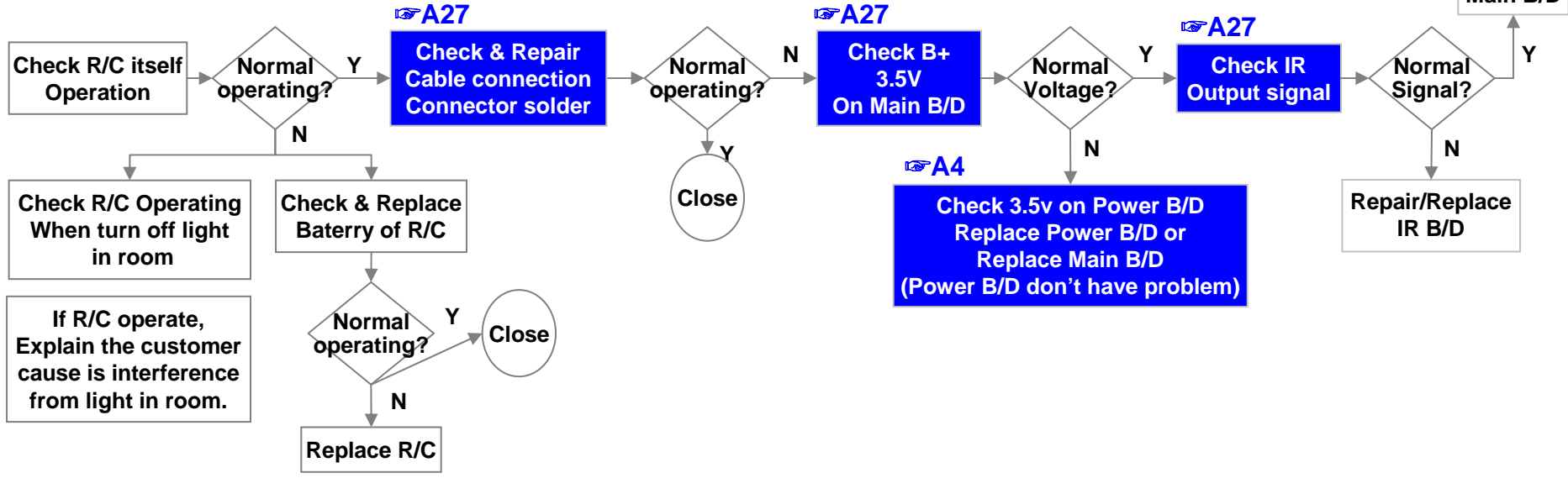

LCD TV	Error symptom	D. Function error	Established date	2012.01.16	
		M4 operating checking	Revised date		11/15

2. M4(Magic Remocon) operating error

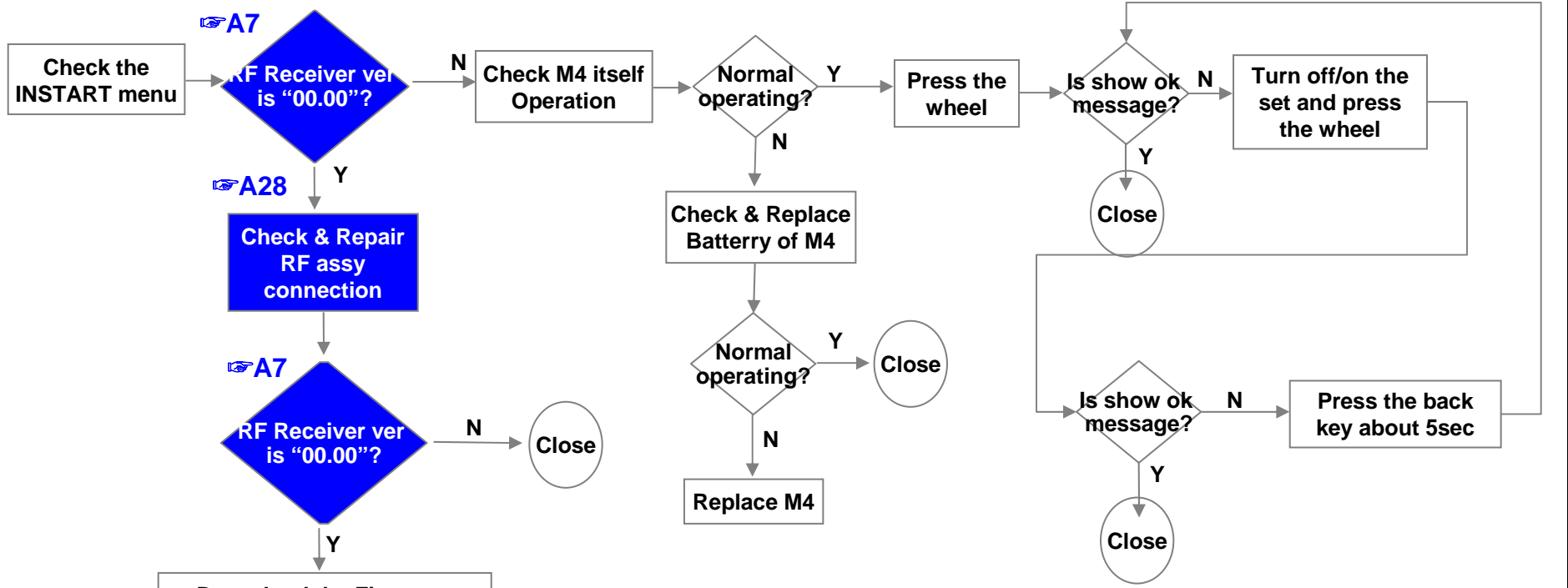

* If you conduct the loop at 3times, change the M4.

LCD TV	Error symptom	D. Function error	Established date	2012.01.16
		Wifi operating checking	Revised date	12/15

3.Wifi operating error

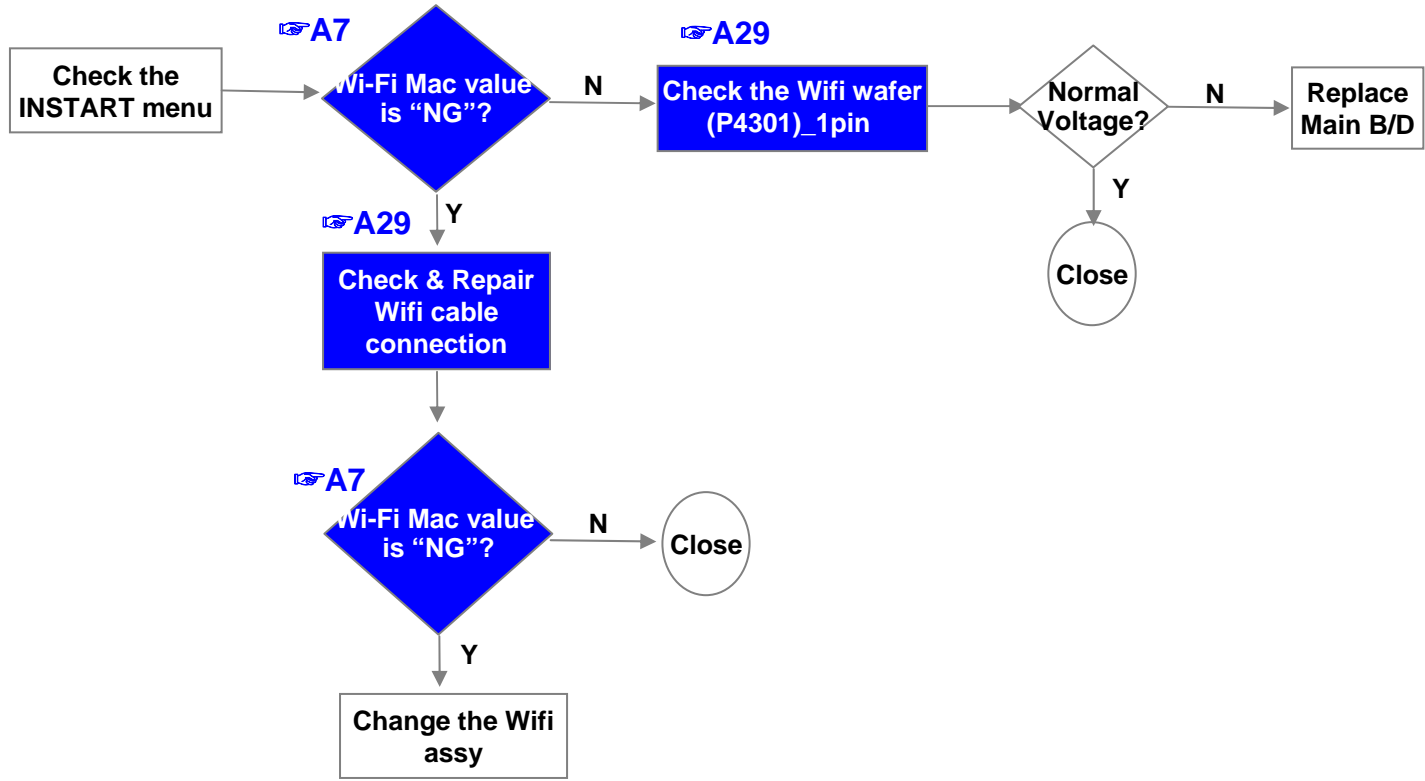

LCD TV	Error symptom	D. Function error	Established date	2012.01.16	
		External device recognition error	Revised date		13/15

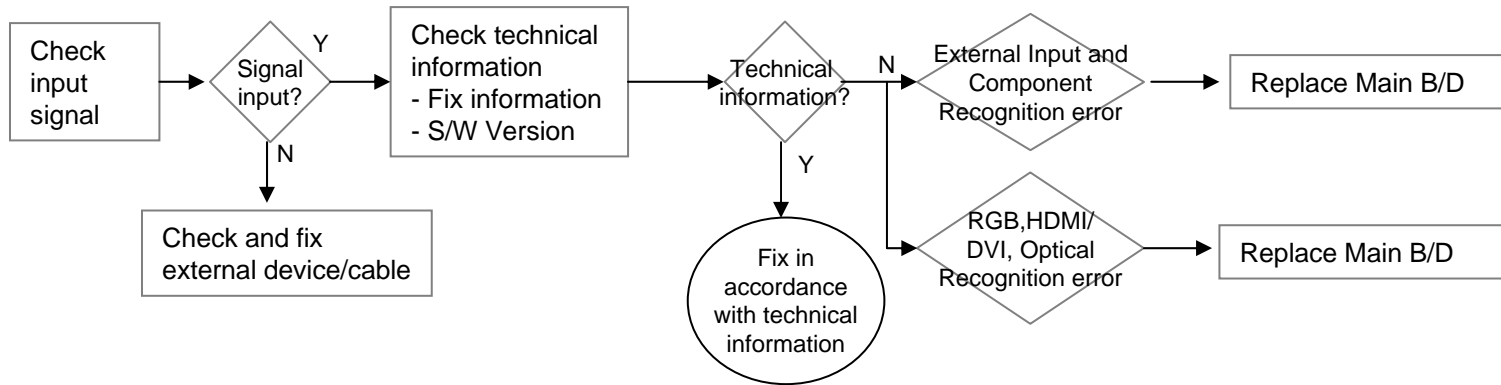

LCD TV	Error symptom	E. Noise	Established date	2012.01.16	
		Circuit noise, mechanical noise	Revised date		14/15

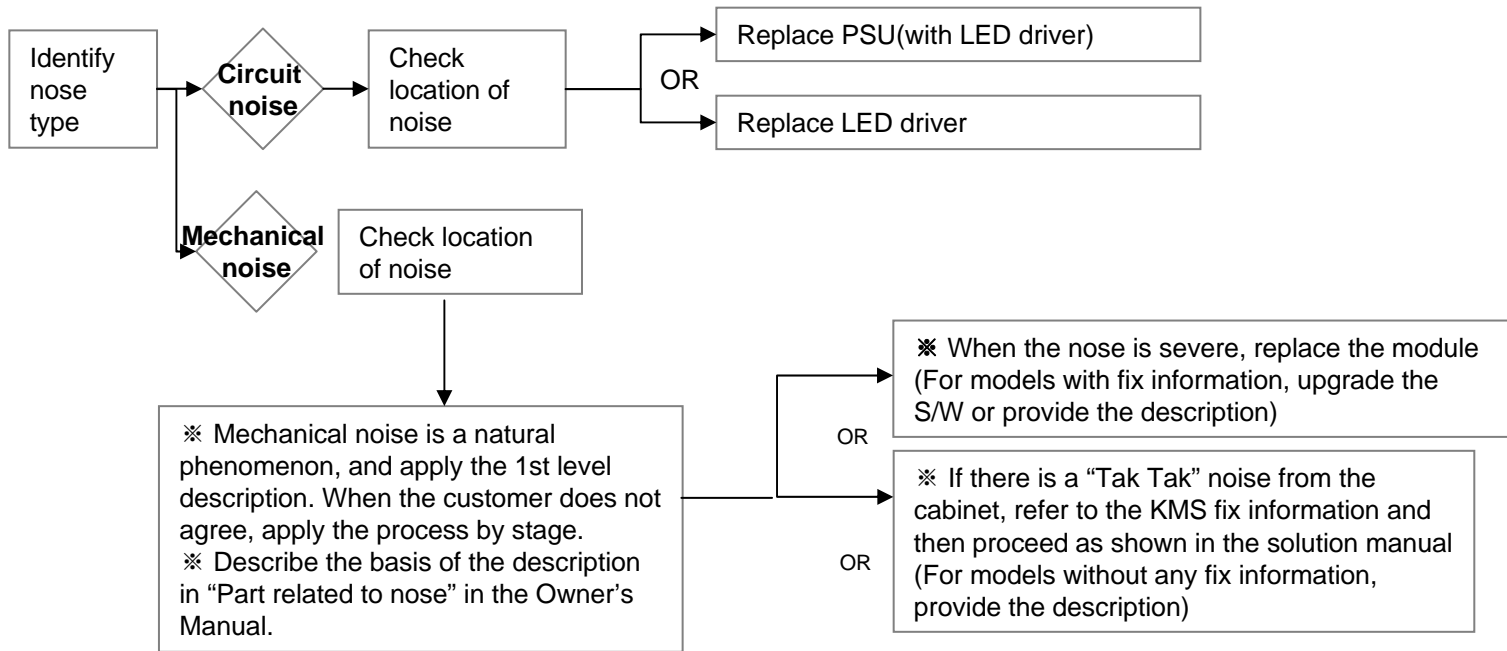

LCD TV	Error symptom	F. Exterior defect	Established date	2012.01.16	
		Exterior defect	Revised date		15/15

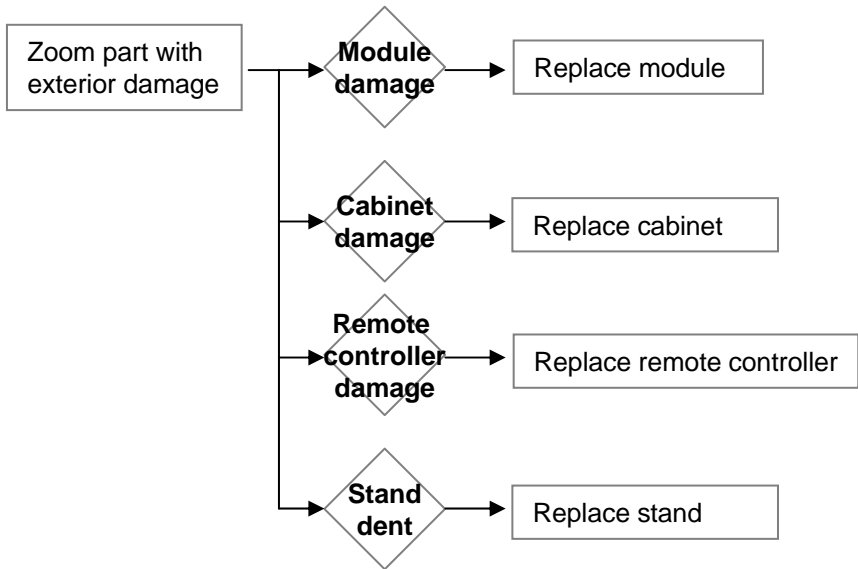

Contents of LCD TV Standard Repair Process Detail Technical Manual

No.	Error symptom	Content	Page	Remarks
1	A. Video error_ No video/Normal audio	Check LCD back light with naked eye	A1	
2		LED driver B+ 24V measuring method	A2	
3		Check White Balance value	A3	
4	A. Video error_ No video/Audio	Power Board voltage measuring method	A4	
5	A. Video error_ video error /Video lag/stop	TUNER input signal strength checking method	A6	
6		LCD-TV Version checking method	A7	
7		Tuner Checking Part	A8	
8	A. Video error _Vertical/Horizontal bar, residual image, light spot	LCD TV connection diagram	A9	
9	A. Video error_ Color error	Check Link Cable (LVDS) reconnection condition	A10	
10		Adjustment Test pattern – ADJ Key	A12	
11	<Appendix> Defected Type caused by T-Con/ Inverter/ Module	Exchange T-Con Board (1)	A-1/5	
12		Exchange T-Con Board (2)	A-2/5	
13		Exchange LED driver Board (PSU)	A-3/5	
14		Exchange Module (1)	A-4/5	
15		Exchange Module (2)	A-5/5	

Continue to the next page

Contents of LCD TV Standard Repair Process Detail Technical Manual

Continued from previous page

No.	Error symptom	Content	Page	Remarks
16	B. Power error_ No power	Check front display LED	A17	
17		Check power input Voltage & ST-BY 3.5V	A18	
18		Checking method when power is ON	A19	
19	B. Power error_Off when on, off while viewing	POWER OFF MODE checking method	A22	
20	C. Audio error_ No audio/Normal video	Checking method in menu when there is no audio	A24	
22		Voltage and speaker checking method when there is no audio	A25	
22	D. Function error	Remote controller operation checking method	A27	
23		Motion Remote operation checking method	A28	
24		Wifi operation checking method	A29	

Standard Repair Process Detail Technical Manual

LCD TV	Error symptom	A. Video error_No video/Normal audio	Established date	2011. 12 .14	
	Content	Check LCD back light with naked eye	Revised date		A1

<XXLM9600>

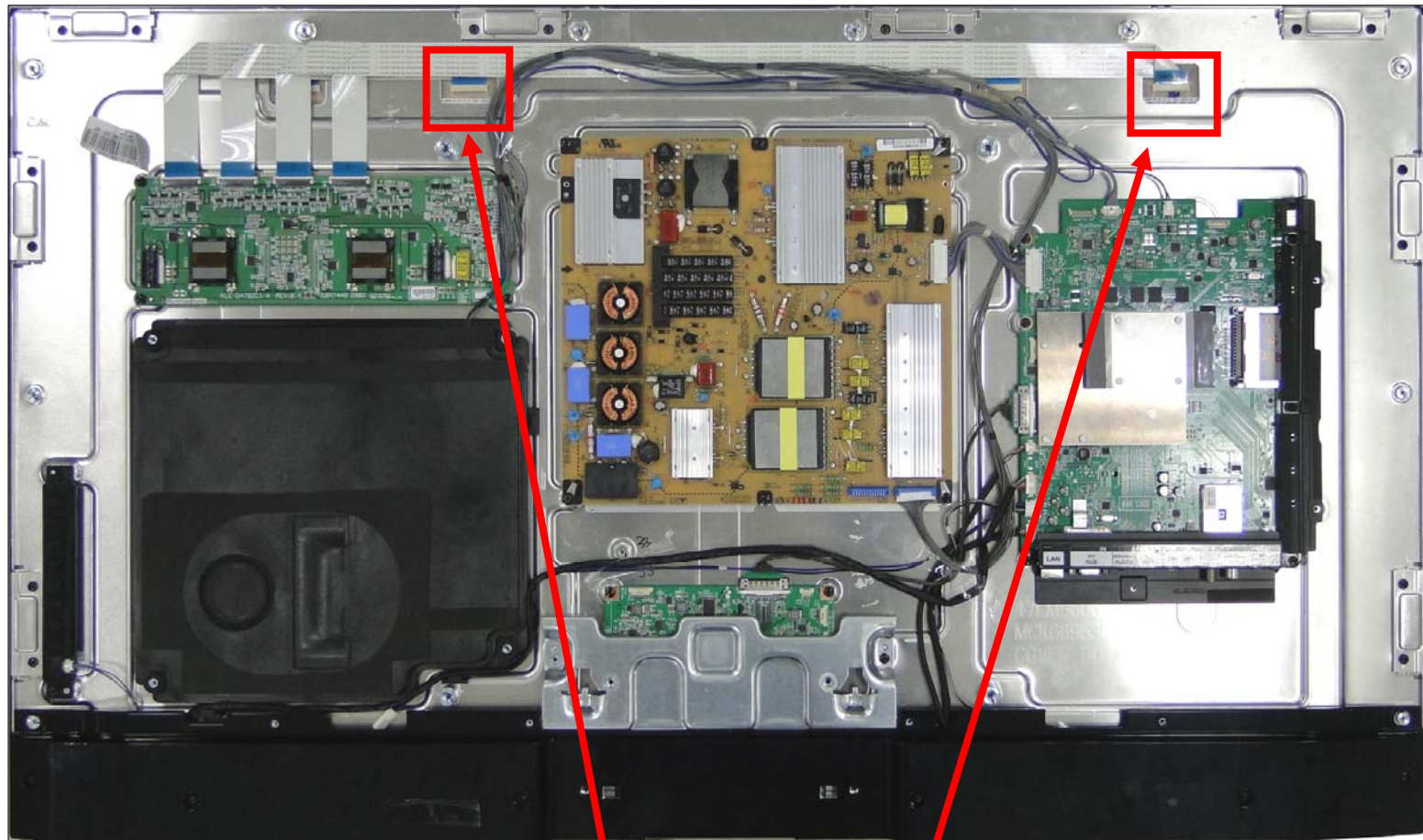

After turning on the power and disassembling the case, check with the naked eye, whether you can see light from 2 locations.

A1

Standard Repair Process Detail Technical Manual

LCD TV	Error symptom	A. Video error_No video/Normal audio	Established date	2011. 12 .14	
	Content	LED driver B+ 24V measuring method	Revised date		A2

Check the DC 24V and Inverter on

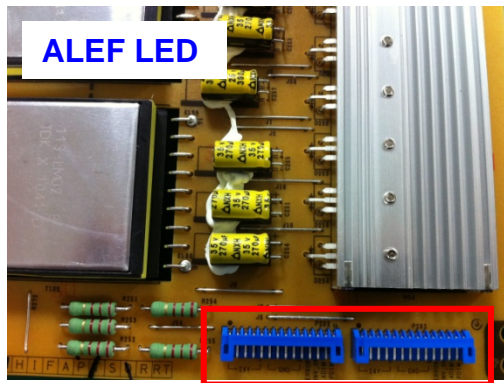

14 Pin (Power Board ↔ Driver) PSU	
1 ~ 5	24V
6 ~ 10	GND
11	Detect
12	Inverter On/Off
13	Int. PWM
14	Ext. PWM (PDIM)

Standard Repair Process Detail Technical Manual

LCD TV	Error symptom	A. Video error_No video/Normal audio	Established date	2011. 12 .14	
	Content	Check White Balance value	Revised date		A3

<ALL MODELS>

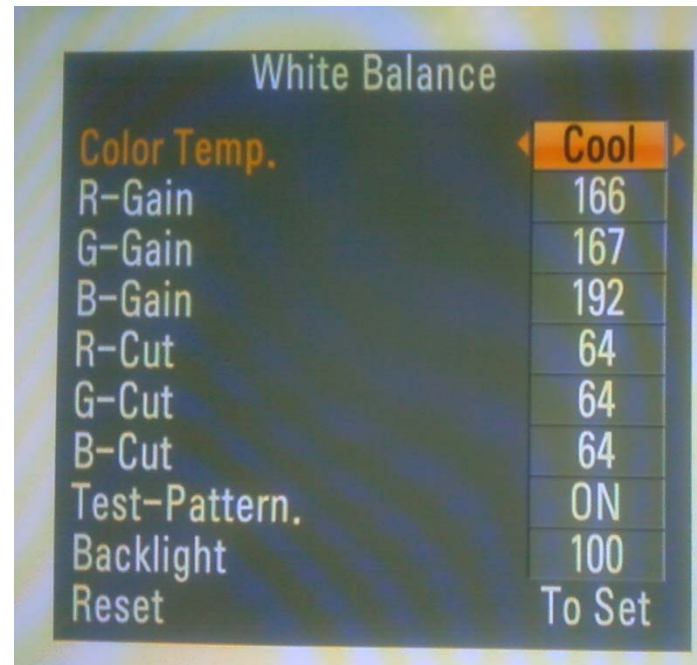
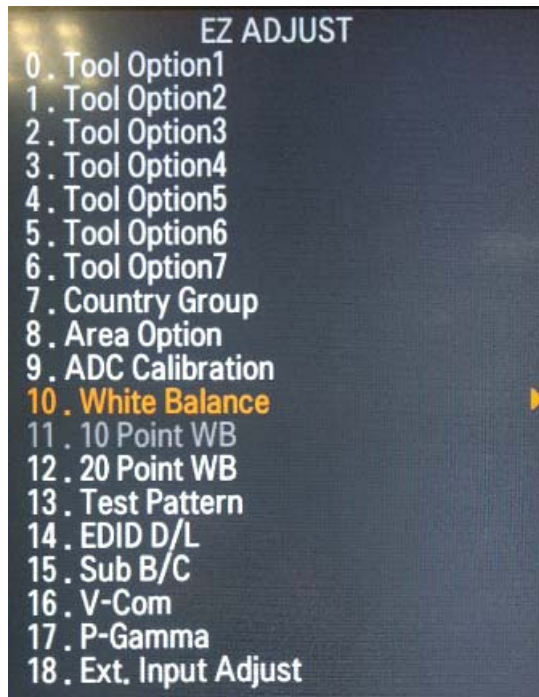

Entry method

1. Press the ADJ button on the remote controller for adjustment.
2. Enter into White Balance of item 10.
3. After recording the R, G, B (GAIN, Cut) value of Color Temp (Cool/Medium/Warm), re-enter the value after replacing the MAIN BOARD.

A3

Standard Repair Process Detail Technical Manual

LCD TV	Error symptom	A. Video error_No video/ Audio	Established date	2011. 12 .14	
	Content	Power Board voltage measuring method	Revised date		A4

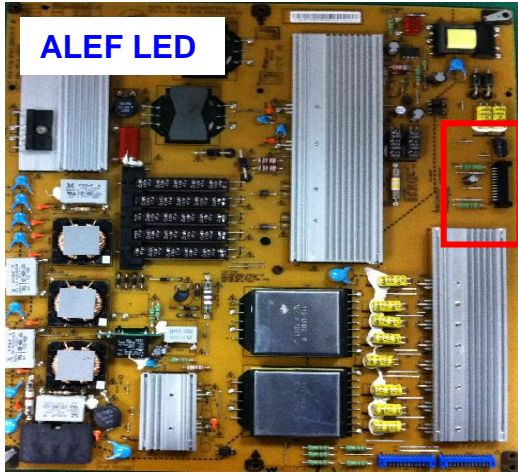

Check the DC 24V, 12V, 3.5V.

24 Pin (Power Board ↔ Main Board) – 공통			
SMAW200-H24S (YEONHO)			
1	Power on	2	20V (24V)
3	20V (24V)	4	20V (24V)
5	GND	6	GND
7	GND	8	GND
9	3.5V	10	3.5V
11	3.5V	12	3.5V
13	GND	14	GND
15	GND	16	N.C (Only LPB : V-sync)
17	12V	18	Inverter On/off
19	12V	20	N.C (LPB, Lamp : A-dim)
21	12V	22	PWM Dim #1
23	N.C (only Lamp SCANNING Model : PWM Dim #2)	24	Error-out

Standard Repair Process Detail Technical Manual

LCD TV	Error symptom	A. Video error_Video error, video lag/stop	Established date	2011. 12 .14	
	Content	TUNER input signal strength checking method	Revised date		A6

<ALL MODELS>



Settings → Set up → Manual Tuning
→ select channel



When the signal is strong, use the attenuator (-10dB, -15dB, -20dB etc.)



Standard Repair Process Detail Technical Manual

LCD TV	Error symptom	A. Video error_Video error, video lag/stop	Established date	2011. 12 .14	
	Content	LCD-TV Version checking method	Revised date		A7

<ALL MODELS>

1. Checking method for remote controller for adjustment

Version

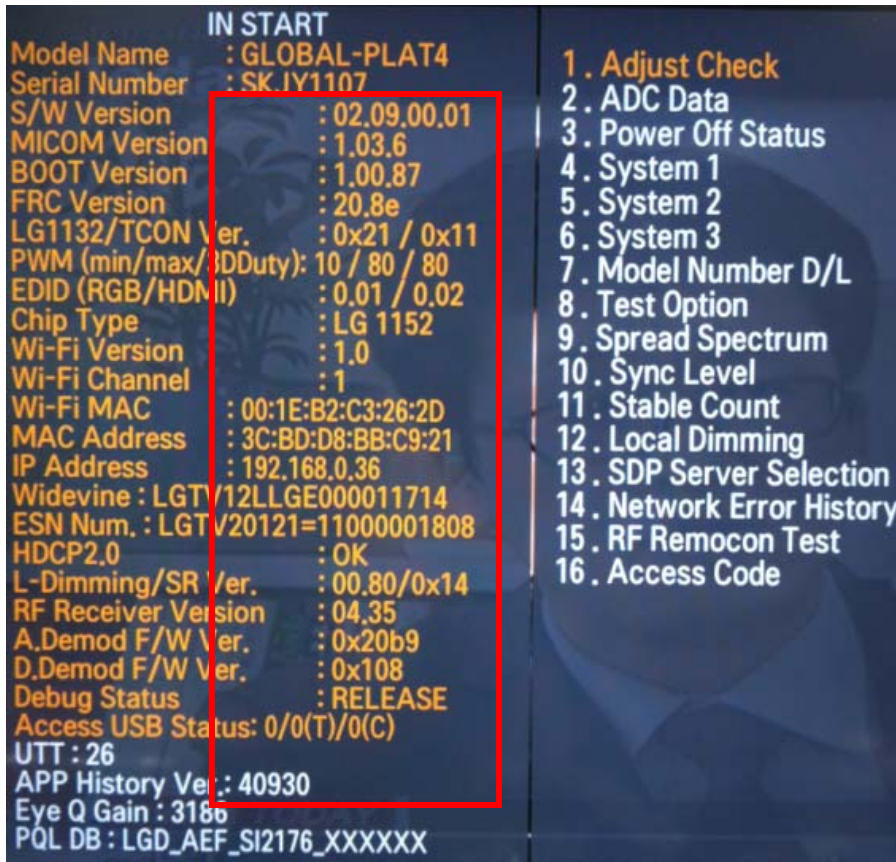

Press the IN-START with the remote controller for adjustment

Standard Repair Process Detail Technical Manual

LCD TV	Error symptom	A. Video error_Video error, video lag/stop	Established date	2011. 12 .14	
	Content	TUNER checking part	Revised date		A8

<ALL MODELS>

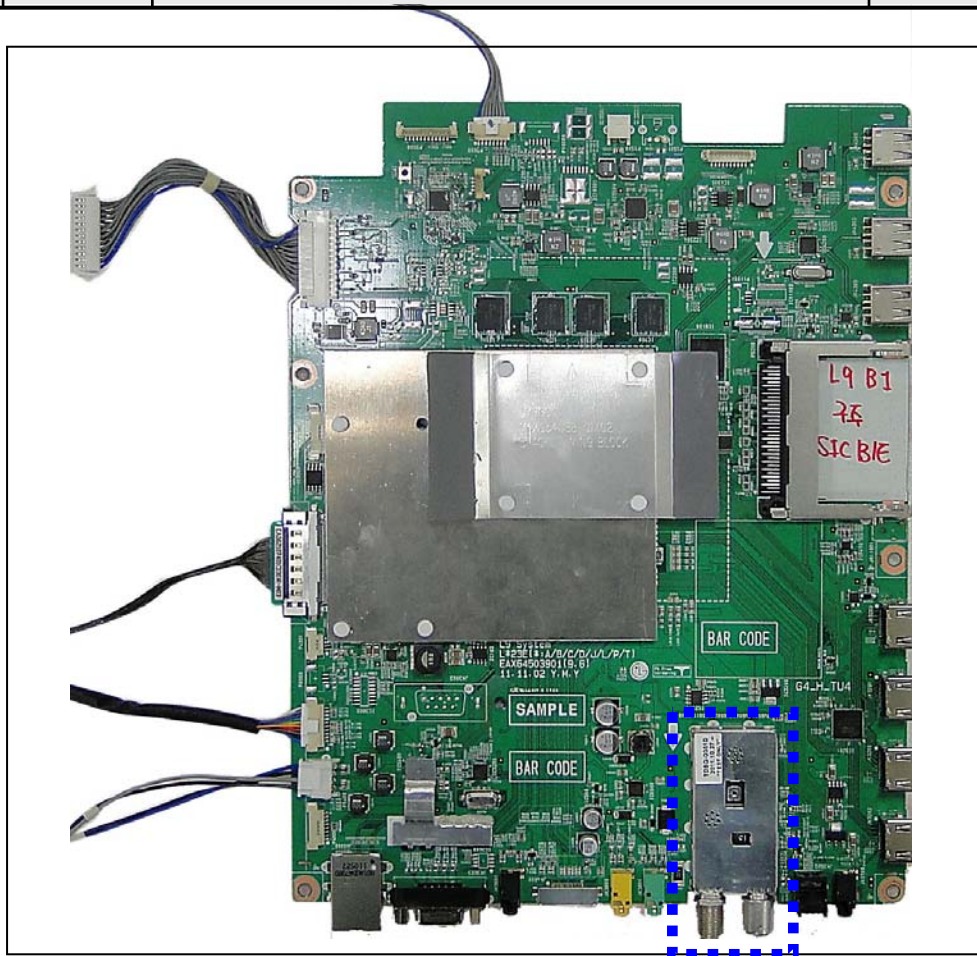

Checking method:

1. Check the signal strength or check whether the screen is normal when the external device is connected.
2. After measuring each voltage from power supply, finally replace the MAIN BOARD.

A8

Standard Repair Process Detail Technical Manual

LCD TV	Error symptom	A. Video error _Vertical/Horizontal bar, residual image, light spot	Established date	2011. 12 .14	
	Content	LCD TV connection diagram (1)	Revised date		A9

<ALL MODELS>

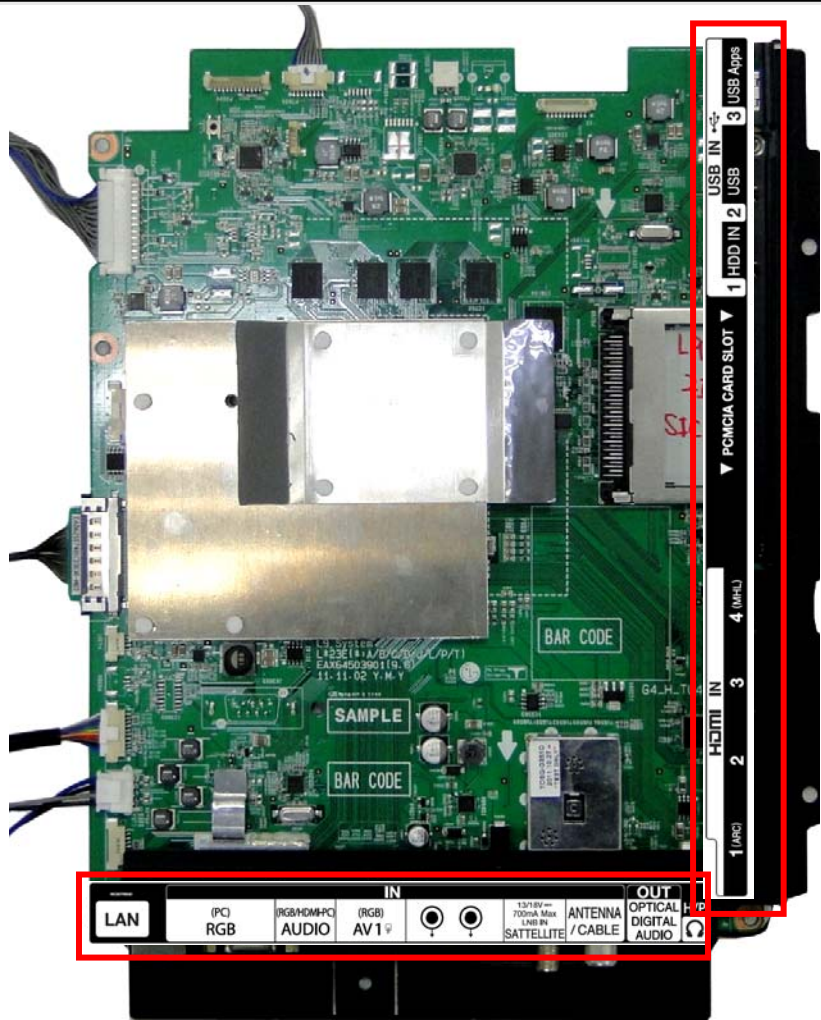

As the part connecting to the external input, check the screen condition by signal

Standard Repair Process Detail Technical Manual

LCD TV	Error symptom	A. Video error_Color error	Established date	2011. 12 .14	
	Content	Check Link Cable (LVDS) reconnection condition	Revised date		A10

<ALL MODELS>

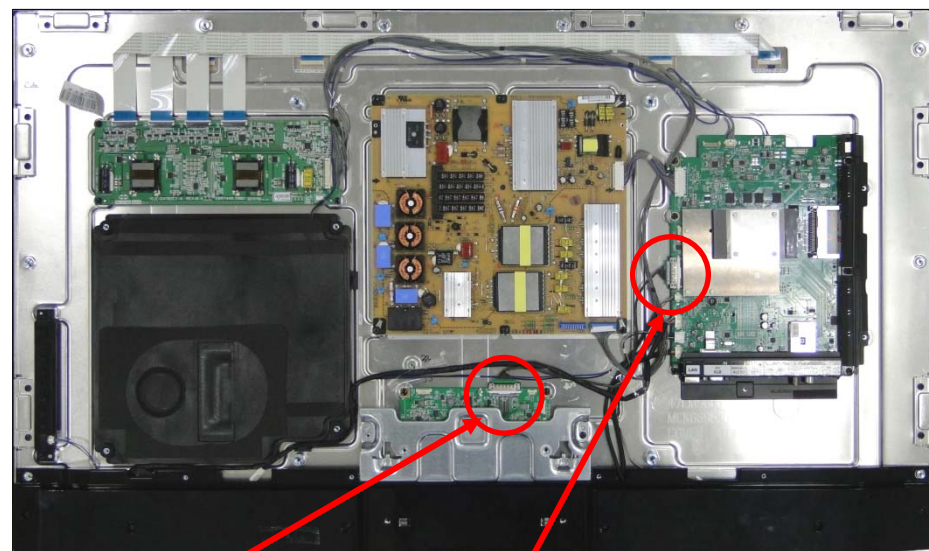
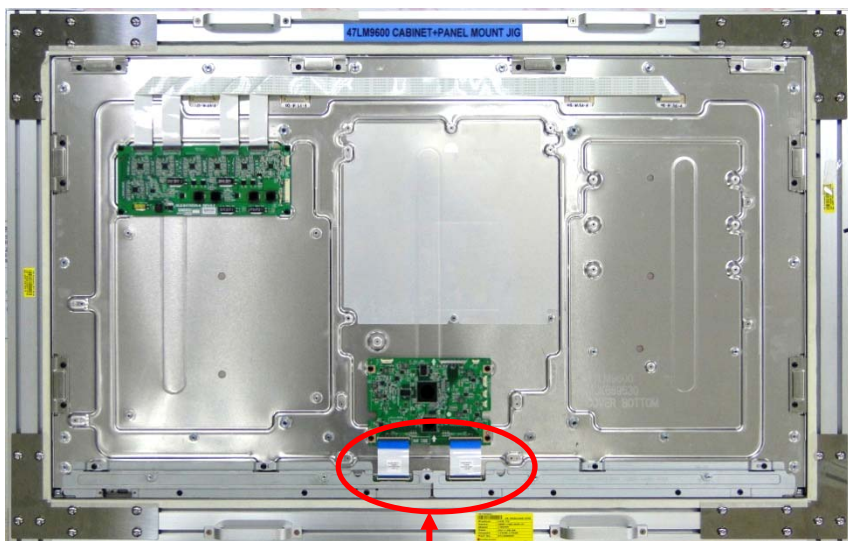

Check the contact condition of the Link Cable, especially dust or mis insertion.

A10

Standard Repair Process Detail Technical Manual

LCD TV	Error symptom	A. Video error_Color error	Established date	2011. 12 .14	
	Content	Adjustment Test pattern - ADJ Key	Revised date		A12

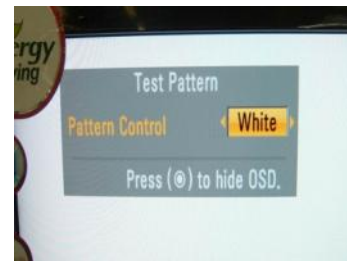
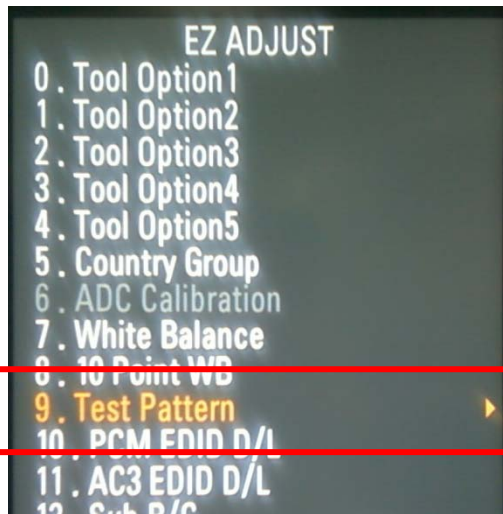

You can view 6 types of patterns using the ADJ Key

Checking item : 1. Defective pixel 2. Residual image 3. MODULE error (ADD-BAR,SCAN BAR..)
4.Video error (Classification of MODULE or Main-B/D!)

A12

Appendix : Exchange T-Con Board (1)



Solder defect, CNT Broken

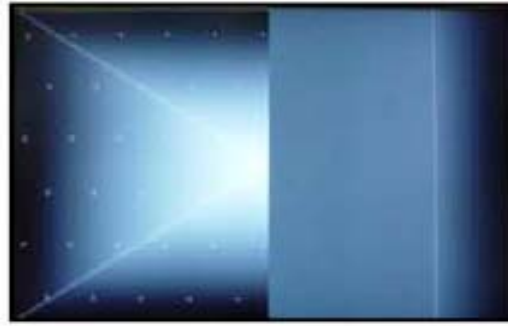

Solder defect, CNT Broken

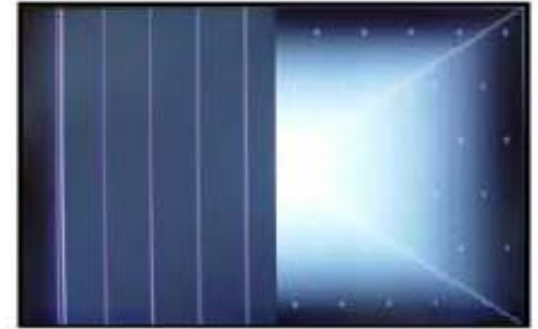

Solder defect, CNT Broken



Solder defect, CNT Broken

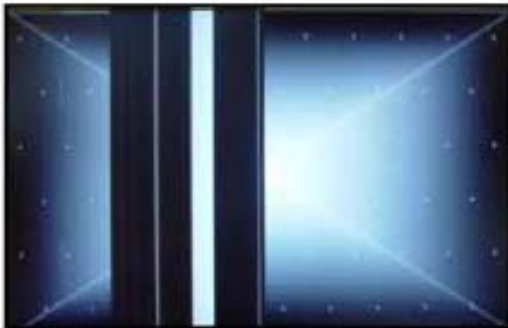

Solder defect, CNT Broken



Abnormal Power Section

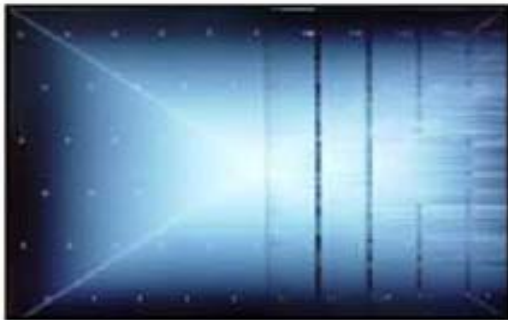

Solder defect, Short/Crack



Abnormal Power Section



Solder defect, Short/Crack

Appendix : Exchange T-Con Board (2)

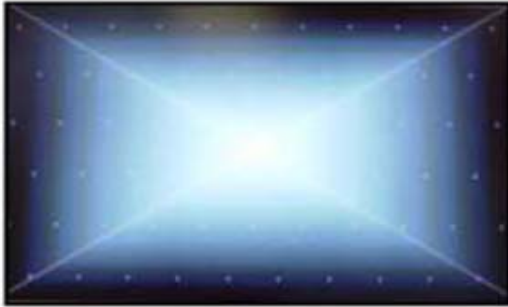

Abnormal Power Section



Abnormal Power Section



Solder defect, Short/Crack



Solder defect, Short/Crack



Fuse Open, Abnormal power section



Abnormal Display



GRADATION



Noise

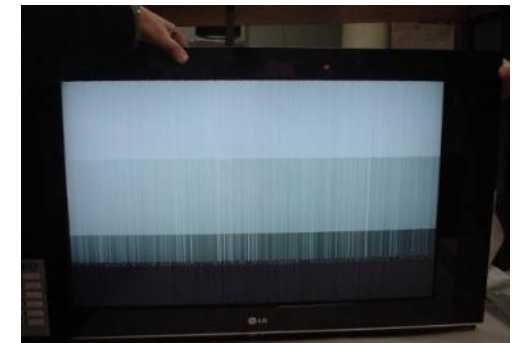

GRADATION

Appendix : Exchange LED driver Board (PSU)



No Light



Dim Light



Dim Light

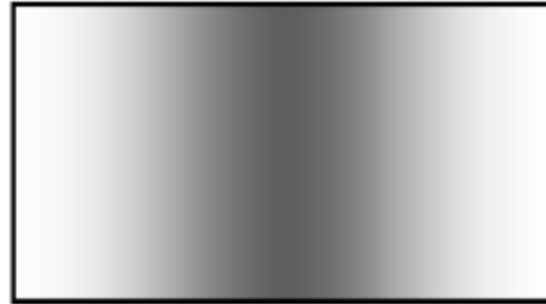

Dim Light



No picture/Sound Ok

Appendix : Exchange the Module (1)



Panel Mura, Light leakage



Panel Mura, Light leakage



Press damage

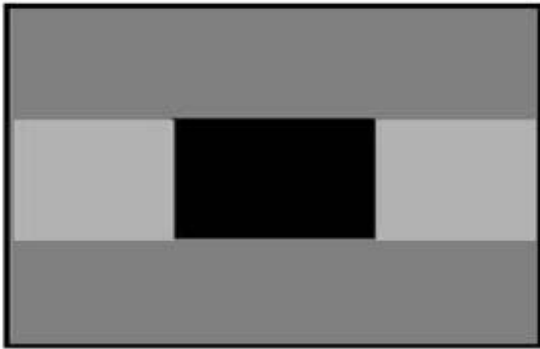

Crosstalk



Press damage



Crosstalk



Press damage

Un-repairable Cases

In this case please exchange the module.

Appendix : Exchange the Module (2)

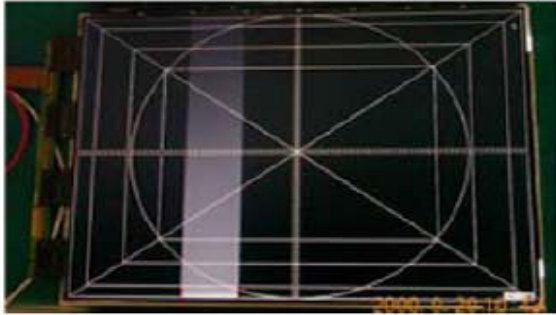

Vertical Block
Source TAB IC Defect



Vertical Line
Source TAB IC Defect



Vertical Block
Source TAB IC Defect



Horizontal Block
Gate TAB IC Defect



Horizontal Block
Gate TAB IC Defect

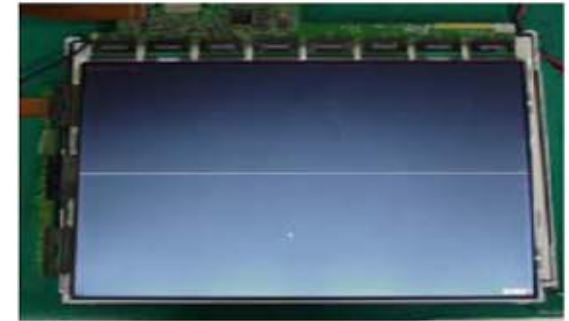

Horizontal line
Gate TAB IC Defect



Horizontal Block
Gate TAB IC Defect

Un-repairable Cases
In this case please exchange the module.

Standard Repair Process Detail Technical Manual

LCD TV	Error symptom	B. Power error _No power	Established date	2011. 12 .14	
	Content	Check front display LED	Revised date		A17

<XXLM9600>

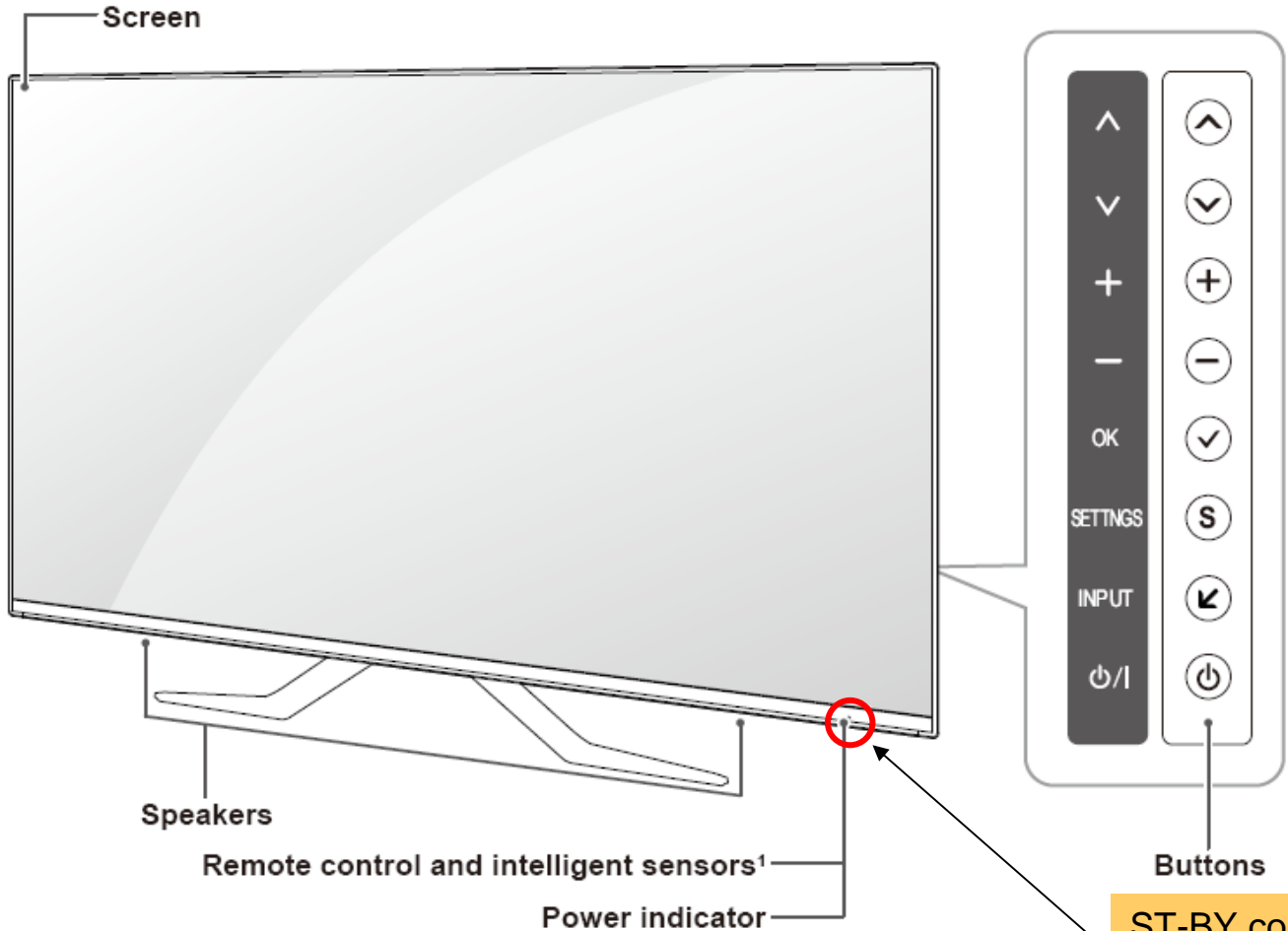

Front LED control :
Menu → Option →
Standby Light
→ ON/ Off

ST-BY condition: Red or Turn Off
Power ON condition: Turn Off

Standard Repair Process Detail Technical Manual

LCD TV	Error symptom	B. Power error _No power	Established date	2011. 12 .14	
	Content	Check power input voltage and ST-BY 3.5V	Revised date		A18

<XXLM9600>

Check the DC 24V, 12V, 3.5V.

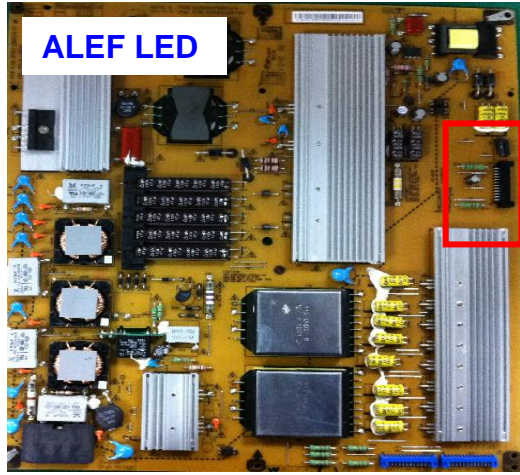

24 Pin (Power Board ↔ Main Board) – 공통			
SMAW200-H24S (YEONHO)			
1	Power on	2	20V (24V)
3	20V (24V)	4	20V (24V)
5	GND	6	GND
7	GND	8	GND
9	3.5V	10	3.5V
11	3.5V	12	3.5V
13	GND	14	GND
15	GND	16	N.C (Only LPB : V-sync)
17	12V	18	Inverter On/off
19	12V	20	N.C (LPB, Lamp : A-dim)
21	12V	22	PWM Dim #1
23	N.C (only Lamp SCANNING Model : PWM Dim #2)	24	Error-out

Standard Repair Process Detail Technical Manual

LCD TV	Error symptom	B. Power error _No power	Established date	2011. 12 .14	
	Content	Checking method when power is ON	Revised date		A19

<XXLM9600>

Check "power on" pin is high

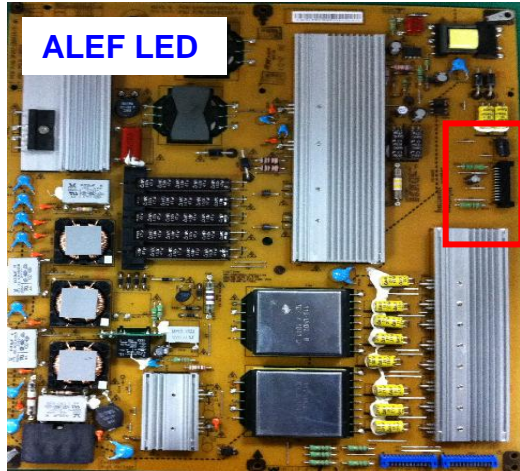

24 Pin (Power Board ↔ Main Board) – 공통			
SMAW200-H24S (YEONHO)			
1	Power on	2	20V (24V)
3	20V (24V)	4	20V (24V)
5	GND	6	GND
7	GND	8	GND
9	3.5V	10	3.5V
11	3.5V	12	3.5V
13	GND	14	GND
15	GND	16	N.C (Only LPB : V-sync)
17	12V	18	Inverter On/off
19	12V	20	N.C (LPB, Lamp : A-dim)
21	12V	22	PWM Dim #1
23	N.C (only Lamp SCANNING Model : PWM Dim #2)	24	Error-out

Standard Repair Process Detail Technical Manual

LCD TV	Error symptom	B. Power error _Off when on, off whiling viewing	Established date	2011. 12 .14	
	Content	POWER OFF MODE checking method	Revised date		A22

<ALL MODELS>

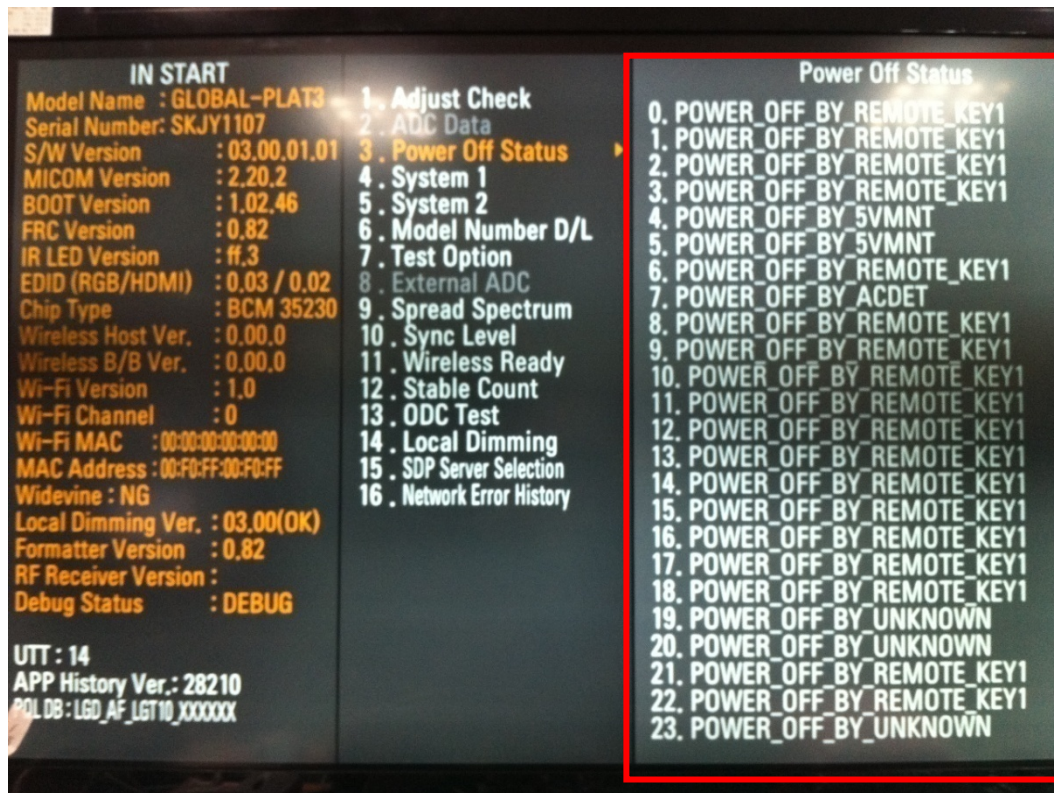

Entry method

1. Press the IN-START button of the remote controller for adjustment
2. Check the entry into adjustment item 3

A22

Standard Repair Process Detail Technical Manual

LCD TV	Error symptom	C. Audio error_No audio/Normal video	Established date	2011. 12 .14	
	Content	Checking method in menu when there is no audio	Revised date		A24

<ALL MODELS>

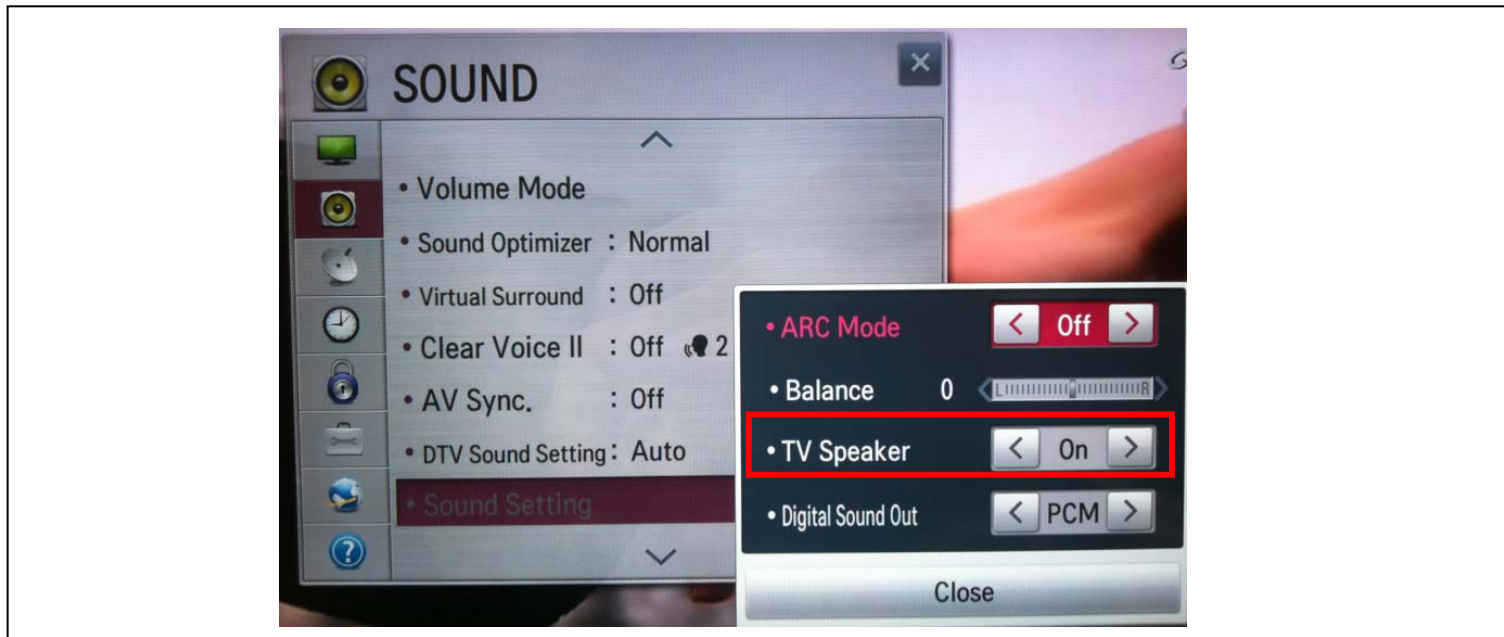

Checking method

1. Press the Setting button on the remote controller
2. Select the Sound function of the Menu
3. Select the Sound Setting
4. Select TV Speaker from Off to On

A24

Standard Repair Process Detail Technical Manual

LCD TV	Error symptom	C. Audio error_No audio/Normal video	Established date	2011. 12 .14	
	Content	Voltage and speaker checking method when there is no audio	Revised date		A25

<XXLM9600>

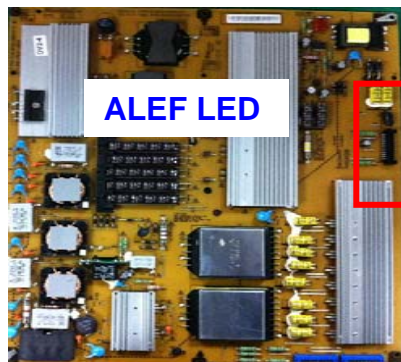

1	Power on	2	24V
3	24V	4	24V
5	GND	6	GND
7	GND	8	GND
9	3.5V	10	3.5V
11	3.5V	12	3.5V
13	GND	14	GND
15	GND	16	V-sync
17	12V	18	Inverter On/off
19	12V	20	N.C
21	12V	22	PWM Dim #1
23	PWM Dim #2	24	Error-out

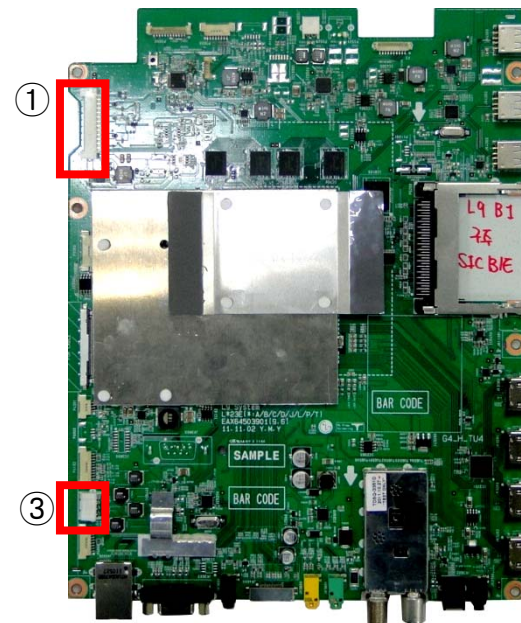

Checking order when there is no audio

① Check the contact condition of or 24V connector of Main Board

② Measure the 24V input voltage supplied from Power Board
(If there is no input voltage, remove and check the connector)

③ Connect the tester RX1 to the speaker terminal and if you hear the Chik Chik sound when you touch the GND and output terminal, the speaker is normal.

A25

Standard Repair Process Detail Technical Manual

LCD TV	Error symptom	D. Function error	Established date	2011. 12 .14	
	Content	Remote controller operation checking method	Revised date		A27

<XXLM9600>

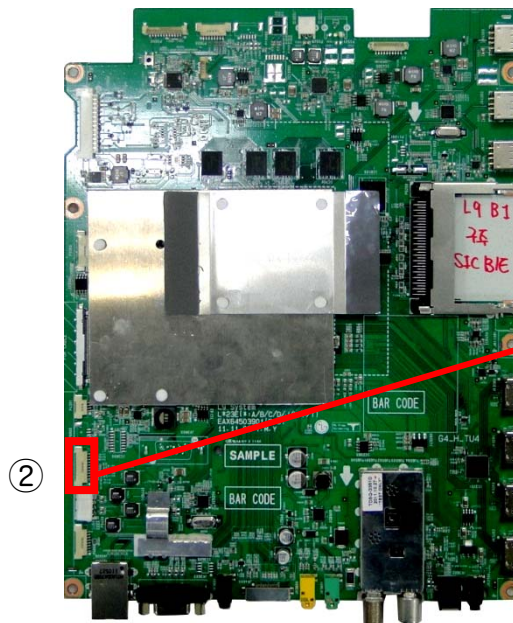
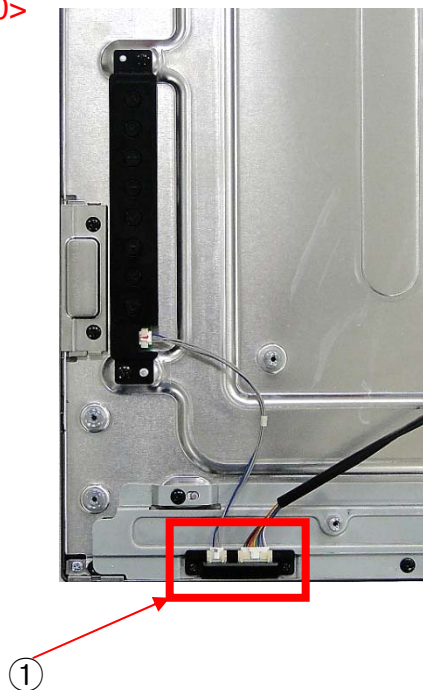

P4102	
1	SCL
2	SDA
3	GND
4	KEY1
5	KEY2
6	St 3.5V
7	GND
8	GP4 LED R
9	IR
10	GND

Checking order

- 1, 2. Check IR cable condition between IR & Main board.
3. Check the st-by 3.3V on the terminal 6.
4. When checking the Pre-Amp when the power is in ON condition, it is normal when the Analog Tester needle moves slowly, and defective when it does not move at all.

Standard Repair Process Detail Technical Manual

LCD TV	Error symptom	D. Function error	Established date	2011. 12 .14	
	Content	Motion Remote operation checking method	Revised date		A28

<XXLM9600>



①

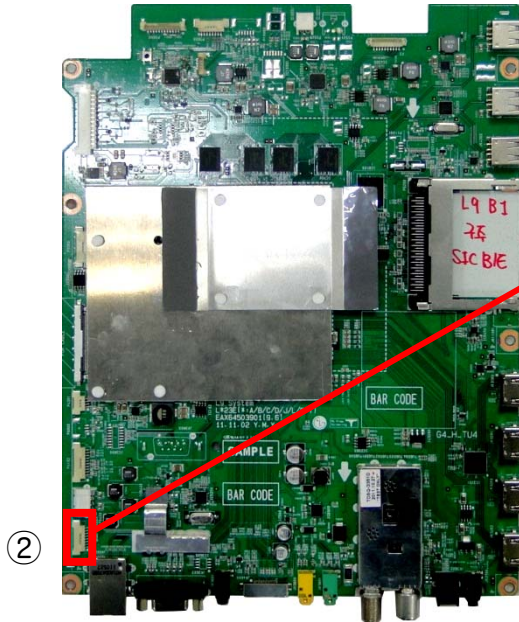

②

③

P4800	
1	3.3V
2	GND
3	RX
4	TX
5	RESET
6	DC
7	DD
8	GND

Checking order

- 1, 2. Check Motion cable condition between Motion assy & Main board.
3. Check the 3.3V on the terminal 1.

Standard Repair Process Detail Technical Manual

LCD TV	Error symptom	D. Function error	Established date	2011. 12 .14	
	Content	Wifi operation checking method	Revised date		A29

<XXLM9600>

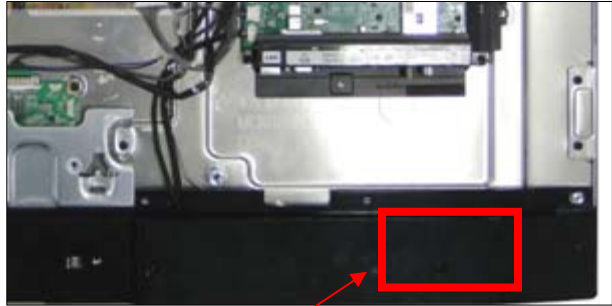

①

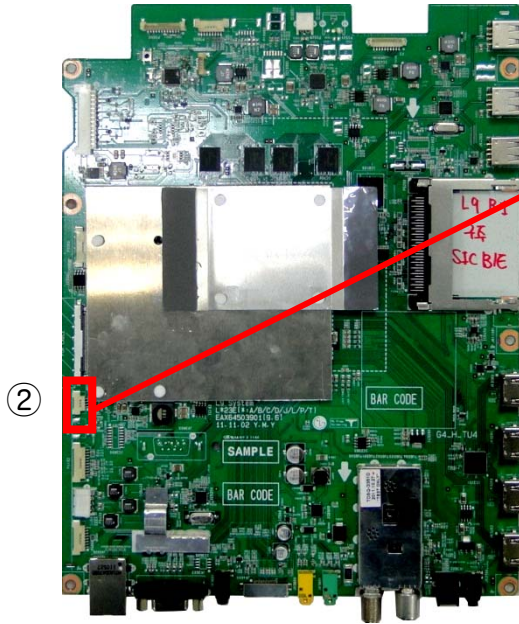

②

③

P4301	
1	VDD
2	DM
3	DP
4	GND

Checking order

- 1, 2. Check Wifi cable condition between Wifi assy & Main board.
3. Check the 5V on the terminal 1.