





WASHING MACHINE SERVICE MANUAL

CAUTION

READ THIS MANUAL CAREFULLY TO DIAGNOSE TROUBLES
CORRECTLY BEFORE OFFERING SERVICE.

**MODEL : AWD-14310(5)FD/AWD-12310(5)FD
WD-14310(5)FD/WD-14311(6)FD
WD-12310(5)FD/WD-12311(6)FD
WD-12811FD/WD-12311HD**

CONTENTS

1. SPECIFICATION.....	3
2. FEATURES & TECHNICAL EXPLANATION	4
3. PARTS IDENTIFICATION	6
4. INSTALLATION.....	7
5. OPERATION.....	10
6. WIRING DIAGRAM / PROGRAM CHART	12
7. TROUBLE SHOOTING.....	13
7-1.BEFORE SVC CHECKING.....	13
7-2.QC TEST MODE.....	13
7-3.HOW TO KNOW THE WATER LEVEL FREQUENCY.....	13
7-4.HOW TO KNOW TO TEMPERATURE OF EACH THERMISTOR AT OPERATING CONDITION.....	13
7-5.ERROR DISPLAY	14
8. ERROR DIAGNOSIS AND CHECK LIST	16
8-1. DIAGNOSIS AND ANSWER FOR ABNORMAL OPERATION.....	16
8-2. FAULT DIAGNOSIS AND TROUBLE SHOOTING	19
9. DISASSEMBLY INSTRUCTIONS	25
10. EXPLODED VIEW AND PARTS LIST	33
10-1. THE EXPLODED VIEW OF CABINET ASSEMBLY	33
10-2. THE EXPLODED VIEW OF CONTROL PANEL AND DISPENSER ASSEMBLY	34
10-3. THE EXPLODED VIEW OF DRUM AND TUB ASSEMBLY	35

1. SPECIFICATION

ITEM		WD-14310(5)FD/WD-14311(6)FD/WD-12310(5)FD/WD-12311(6)FD/WD-12811FD AWD-14310(5)FD/AWD-12310(5)FD/WD-12311HD	
POWER SUPPLY		220V-240V~, 50Hz	
PRODUCT WEIGHT		64kg	
ELECTRICITY CONSUMPTION	WASHING	140W	
	SPIN	300W	
	DRAIN MOTOR	40W	
REVOLUTION SPEED	WASH HEATER	2000W	
	WASH	45rpm	
	SPIN	WD-14310(5)FD/14311(6)FD/AWD-14310(5)FD	400/800/1000/1400 rpm
		WD-12310(5)FD/12311(6)FD/12811FD/12311HD/AWD-12310(5)FD	400/800/1000/1200 rpm
OPERATION WATER PRESSURE		0.3-10kgf/cm ² (30-1000kPa)	
CONTROL TYPE		Electronic	
WASH CAPACITY		8Kg(Cotton)	
DIMENSION		600mm(W) ×645mm(D) ×850mm(H)	
WASH PROGRAM		Cotton, Cotton-Eco, Synthetic, Delicate, Wool/Silk, Hand Wash, Quick 30, Duvet, Drain	
RINSE		Normal / Rinse ⁺ / Rinse ⁺⁺ / Normal+Hold / Rinse ⁺ +Hold	
DOOR SWITCH TYPE		Bi-Metal type	
WATER LEVEL		10 steps (by sensor)	
RESERVATION		From 3 hours to 19 hours	
SENSING OF THE LAUNDRY AMOUNT		Adapted	
FUZZY LOGIC		Adapted	
DISPLAY OF THE REMAINING TIME		Adapted	
ERROR DIAGNOSIS		10 items	
POWER AUTO OFF		Adapted	
CHILD LOCK		Adapted	
AUTO RESTART		Adapted	
TIME SAVE		Adapted	

2. FEATURES & TECHNICAL EXPLANATION

2-1.FEATURES



■ Jumbo drum

LG's jumbo drum can wash about 40% more load than conventional washing machine. A bigger drum improves the wash performance.

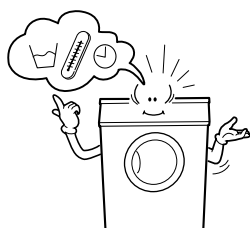

■ More economical by Intelligent Wash System

Intelligent Wash System detects the amount of load and water temperature, and then determines the optimum water level and washing time to minimize energy and water consumption.

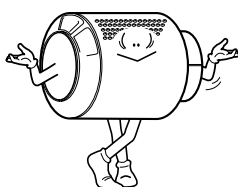

■ Direct Drive system

The advanced Brushless DC motor rotates the Drum directly without belt and pulley.

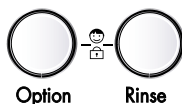

■ Child-Lock

The Child-Lock system has been developed to prevent children from pressing any button to change the program during operation.

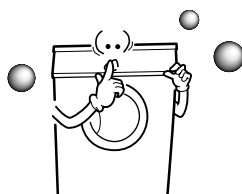

■ Low noise speed control system

By sensing the amount of load and balance, evenly distributes load to minimize the spinning noise level.

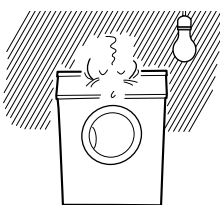

■ Auto Restart

Although the washing machine is turned off by a power failure, it restarts automatically in its stopped process when power is supplied again. And it will be the same when the machine unplugged in operation is plugged in again.



■ Safety device (Aqua lock)

[WD-14310(5)FD/12310(5)FD]

Aqua lock System is designed for detecting water leak during operation to prevent water from flooding over the floor.

2-2.DETERMINE WASHING TIME BY FUZZY LOGIC

To get the best washing performance optimal time is determined by sensing of water temperature, selected washing temperature and laundry amount.

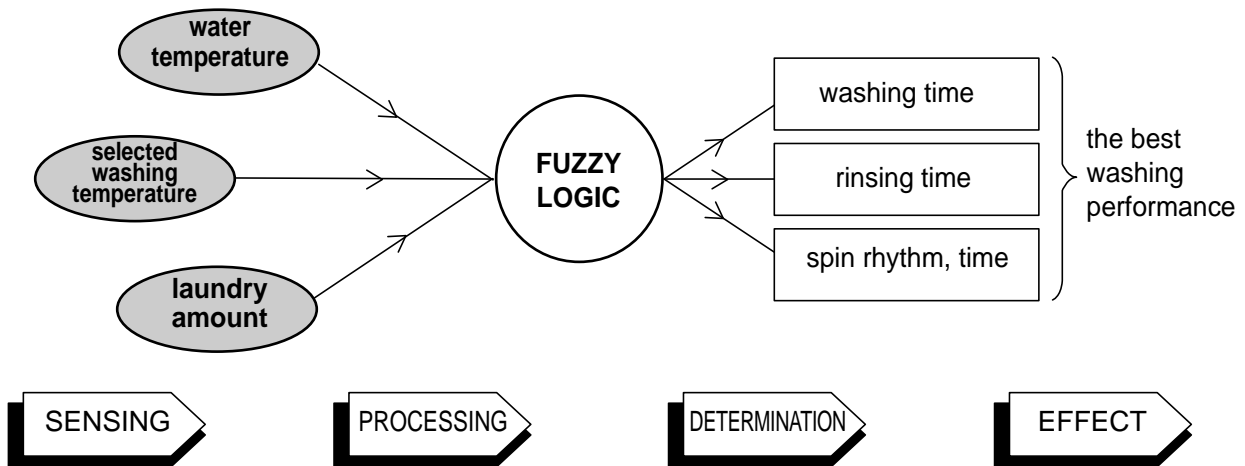

2-3.WATER LEVEL CONTROL

- This model adopts a pressure sensor which can sense the water level in the tub.
- Water supply is stopped when the water level to the preset level, then washing program proceeds.
- Spinning does not proceed until the water in the tub reduces to a certain level.

3. PARTS IDENTIFICATION

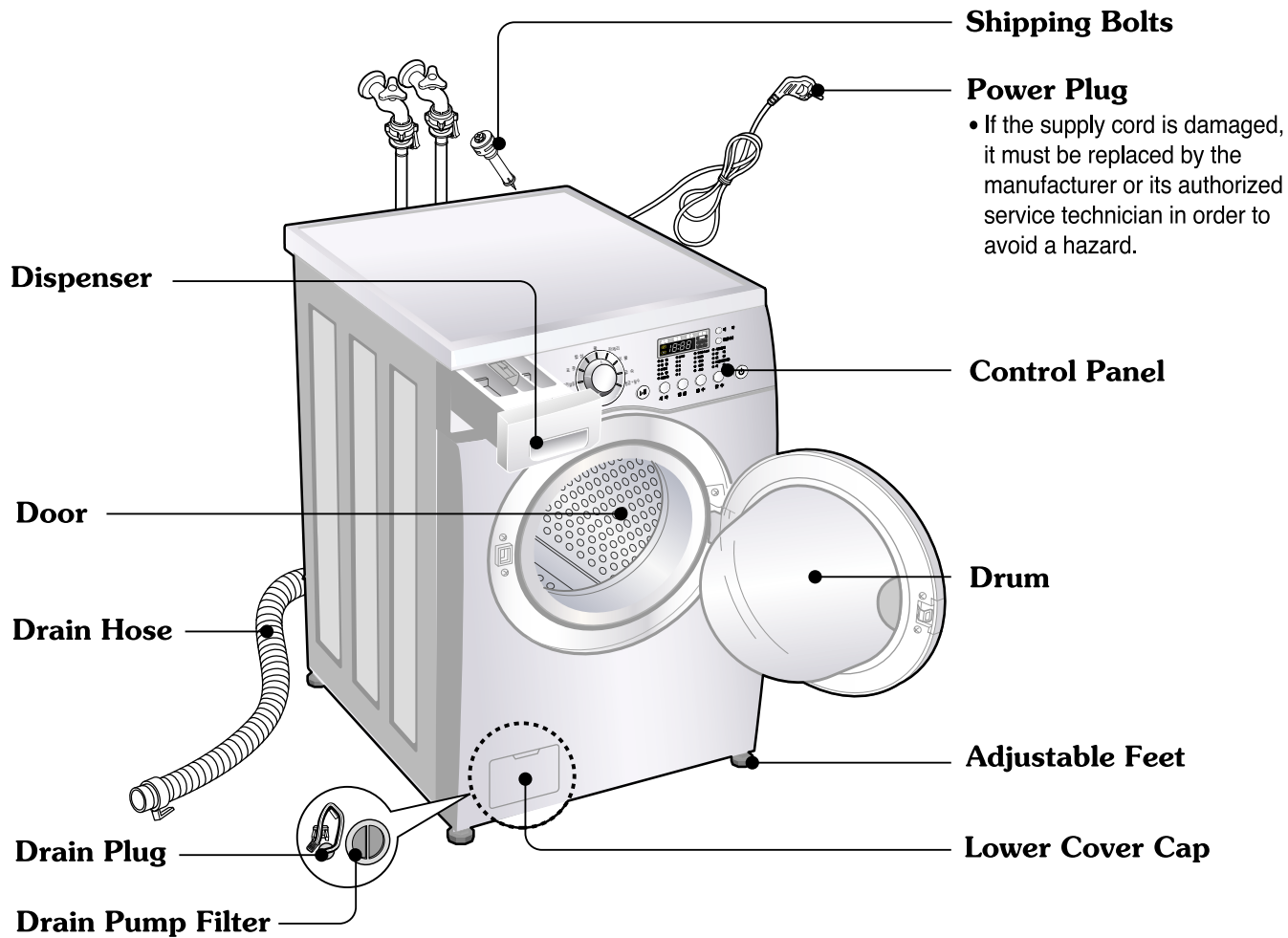

■ ACCESSORIES



4. INSTALLATION

- ① Before servicing ask troubles of customers
- ② Check the adjustment(power supply is 220-240V~, remove the transit bolts....)
- ③ Check the troubles referring to the trouble shooting.
- ④ Decide service steps referring to disassembly instructions.
- ⑤ And then, service and repair.
- ⑥ After servicing, operate the appliance whether it works O.K or NOT.

■ STANDARD INSTALLATION

The appliance should be installed as follows.

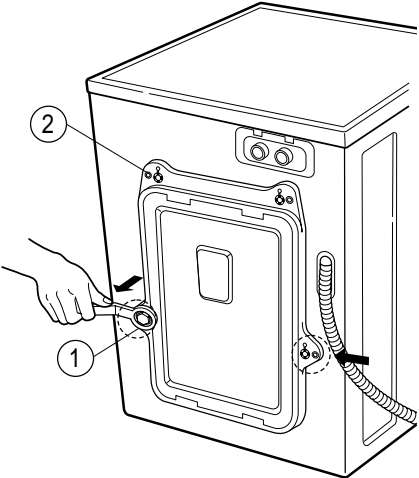
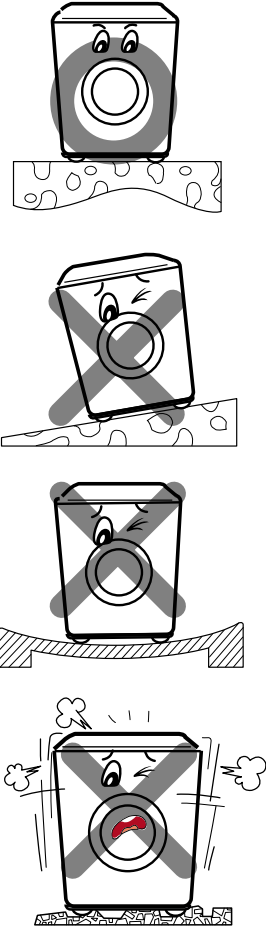
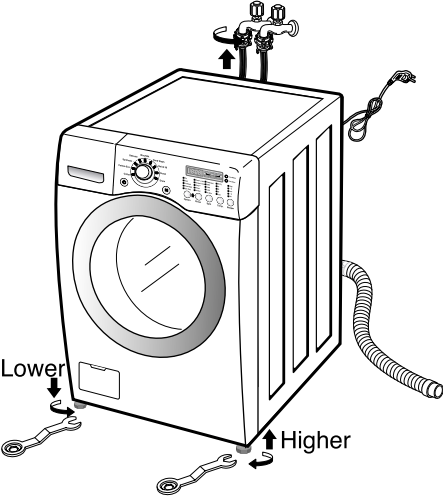
REMOVE THE TRANSIT BOLTS	INSTALL THE APPLIANCE ON FLAT AND FIRM SURFACE	ADJUST THE HORIZONTAL
<ul style="list-style-type: none"> • Remove the transit bolts (4EA: ①) with supplied spanner. • Keep the transit bolts and spanner for future use. • Insert the 4 caps provided into the hole 		<ul style="list-style-type: none"> • Turn the leveling feet to set the appliance horizontally.  <ul style="list-style-type: none"> • The appliance goes up by rotating the feet clockwise. • The appliance come down by rotating the feet counter clockwise.

■ HOW TO CONNECT INLET HOSE

- Check that the rubber packing is inside of the valve connector.
- Connect the inlet hose firmly to prevent leak.

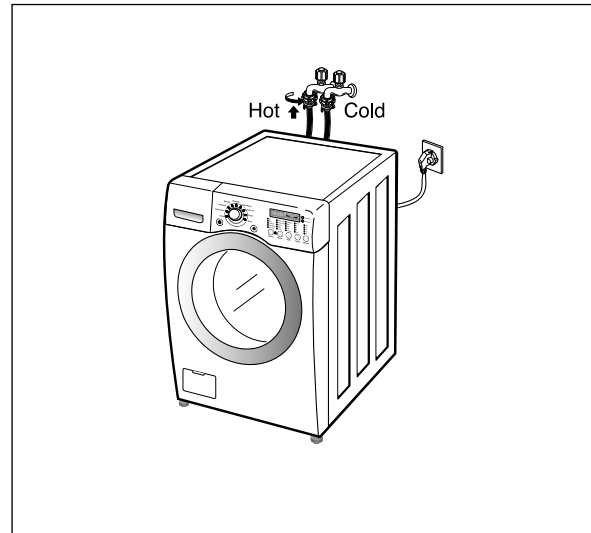

■ CONNECT DRAIN HOSE

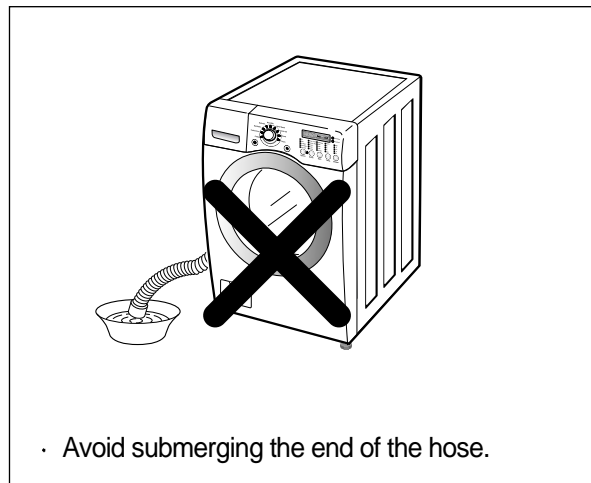
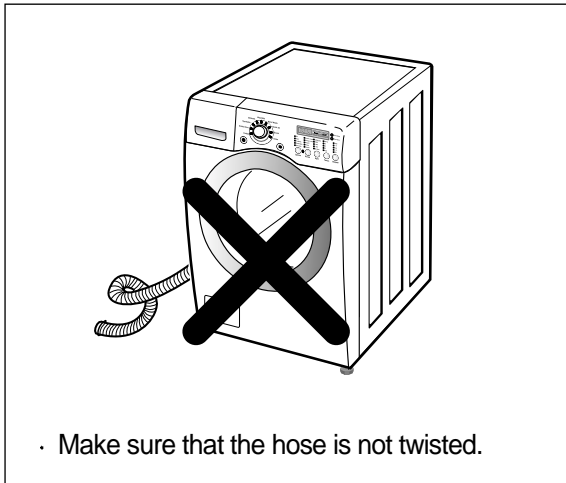

※ The drain hose should be placed under 100cm from the floor.

■ CONNECT POWER PLUG

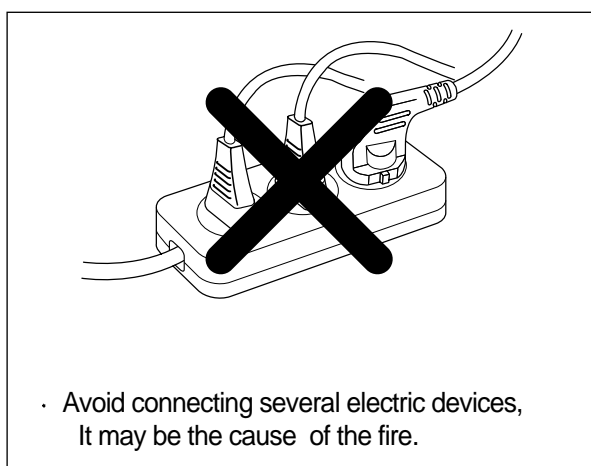
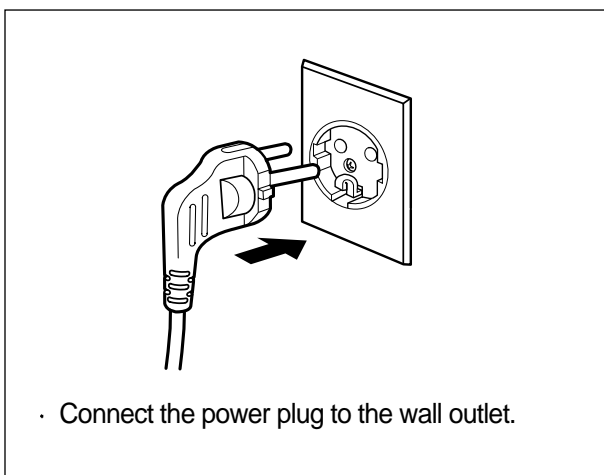

7 TEST OPERATION

1 Preparation for washing.

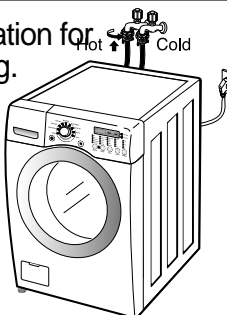

- Connect the power plug to the outlet.
- Connect the inlet hose.

2 Press the POWER button.



3 Press the Start/Pause button.



- In case of Coloreds program.

6 Check the water heating.

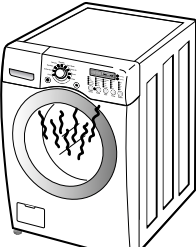

- Press the Temp. button and the present temperature will be displayed.

5 Check automatic reverse turn.



- Check if the drum rotates clockwise and counterclockwise.

4 Check the water supply.

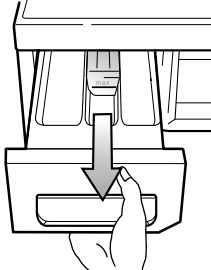

- Check if water is supplied through the detergent dispenser.

7 Check drain and spin

- Turn off Wash and Rinse after pressing the Start/Pause button and start the machine again.
- Check drain and spin.

8 Power off and open the door



- Power off and then power on.
- Check if the door can be opened after 3 minutes.

9 Water removal

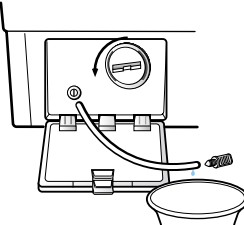

- If SVC is needed during check, remove the remaining water by pulling out the hose cap.

5. OPERATION

• POWER button

- Use this button to turn the power **On/Off**.

• EST.TIME REMAINING

- This display shows:
 - a) the estimated time remaining in the cycle when operating.
 - b) an error code when an error has been detected.

• CHILD LOCK

- Use this option to prevent children from operating the washer. Press and hold PRE WASH for 3 seconds to lock/unlock control.
- When Child lock is set, all buttons are disabled except the power button. You can lock the washer with the power button.

• CYCLE SELECTOR knob

- Rotate the **Cycle selector knob** to select the cycle designed for different types of fabric and soil levels.

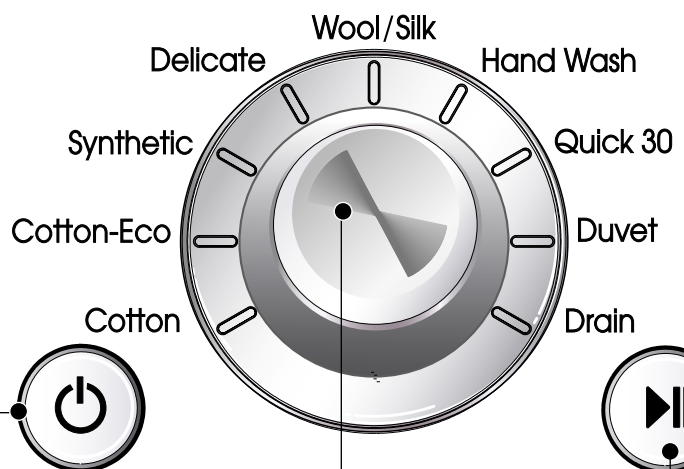

• START/PAUSE button

- Use this button to **Start/Stop** the washer.

• OPTION button

- **Pre Wash:** Use this option for loads that need pretreatment. It adds 16 minutes of prewash and drain.
- **Rinse+Spin:** Use this option to rinse and then spin.
- **Soak:** Use this mode to wash normal clothes or thick and heavy clothes which are excessively dirty.
- **Spin Only:** When you want Spin only, select this option.
- **Bio:** If you want to eliminate protein stains, you may select Bio function.

LOCK

Prevent unwanted use of the washer. Press the WASH button for 3 seconds to lock the washer.

When locked, CHILD LOCK lights and all buttons are disabled except the Power (⏻) button. You can unlock the washer while it is operating.

• STATUS INDICATOR

- These lights show which portion of the cycle the washer is operating.

• TIME DELAY

- Allows the start of any cycle to be delayed for 3~19 hours.

• INTENSIVE

- If the laundry is heavily soiled "Intensive" option is effective.
- By selecting the Intensive option, the wash time may be extended, depending on the program selected.
- To use this option press the Intensive button once before the wash program is started.

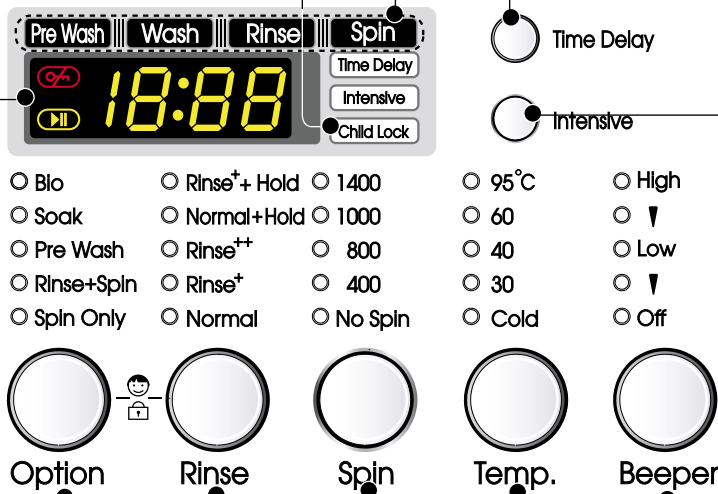

• Rinse, Spin, Temp. Button

- Select a water temperature based on the type of load you are washing.
- To change the spin speed, press the Spin Speed button repeatedly to cycle through available options.
- To change the soil level, press the Soil Level button repeatedly until the desired setting is on.

• Beeper Button

- Press repeatedly to adjust the volume of the Beeper.

6. WIRING DIAGRAM / PROGRAM CHART

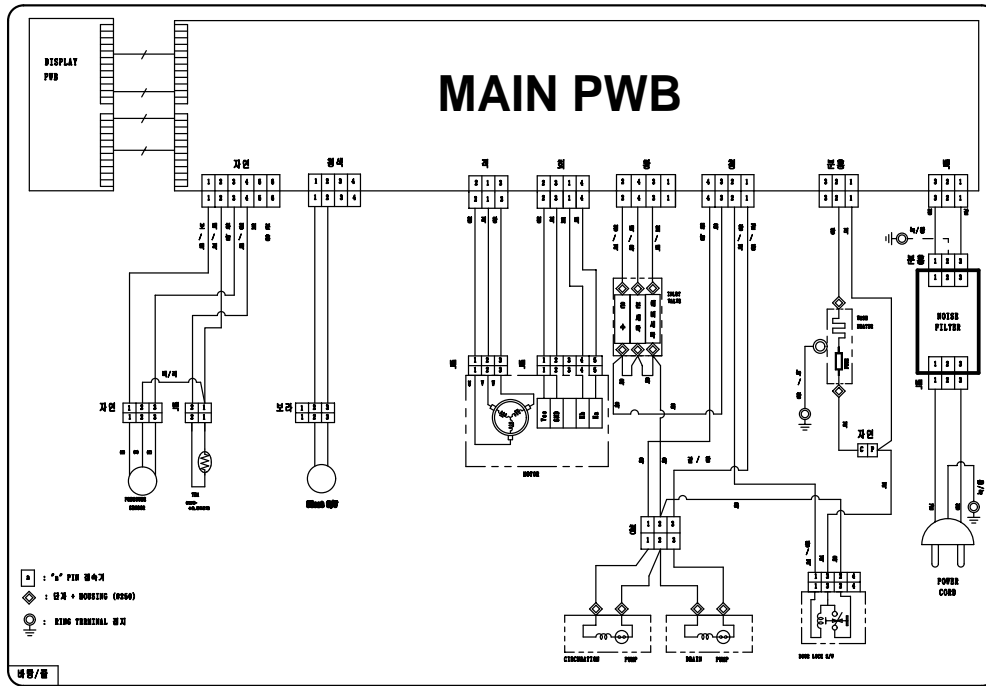

PRGRAM CHART

* Water Supply : W·S

* Intermittent Spin : I·S

* Disentangle : D·T

CYCLE	Wash				Rinse												Spin			D·T	Diy	END	AUTO OFF	**Approx Working Time (Minutes)										
	Pre		Main		1		2		3		Extra & Stain(4-6)				Drain	Spin	D·T																	
	W·S	Wash	Drain	I·S	W·S	Wash Heat	Drain	I·S	W·S	Rinse	Drain	I·S	W·S	Rinse				Drain	I·S						W·S	Rinse								
STEP	1	2	3	4	5	6	7	8	9	10	11	12	13	14	15	16	17	18	19	20	21	22	23	24	25	26	27	20	20					
COURSE	TIME (SEC.)																																	
Cotton	60	8	60	180	120	42	60	180	120	180	60	240	120	180	60	180	120	180	60	180	120	180	60	180	120	180	60	480	180	0	0	0	0	About 1:53
Synthetic	60	8	60	180	120	42	60	180	120	180	60	240	120	180	60	180	120	180	60	180	120	180	60	180	120	180	60	480	180	0	0	0	0	About 1:15
Wool/Silk	60	8	60	180	120	42	60	180	120	180	60	240	120	180	60	180	120	180	60	180	120	180	60	180	120	180	60	480	180	0	0	0	0	About 55
Delicate	60	8	60	180	120	42	60	180	120	180	60	240	120	180	60	180	120	180	60	180	120	180	60	180	120	180	60	480	180	0	0	0	0	About 1:05
Duvet	60	8	60	180	120	42	60	180	120	180	60	240	120	180	60	180	120	180	60	180	120	180	60	180	120	180	60	480	180	0	0	0	0	About 1:00
Quick 30	60	8	60	180	120	42	60	180	120	180	60	240	120	180	60	180	120	180	60	180	120	180	60	180	120	180	60	480	180	0	0	0	0	About 30
Cotton-Eco	60	8	60	180	120	42	60	180	120	180	60	240	120	180	60	180	120	180	60	180	120	180	60	180	120	180	60	480	180	0	0	0	0	About 2:03
Hand Wash	60	8	60	180	120	42	60	180	120	180	60	240	120	180	60	180	120	180	60	180	120	180	60	180	120	180	60	480	180	0	0	0	0	About 50
Rinse+Spin	60	8	60	180	120	42	60	180	120	180	60	240	120	180	60	180	120	180	60	180	120	180	60	180	120	180	60	480	180	0	0	0	0	About 33
Wash	60	8	60	180	120	42	60	180	120	180	60	240	120	180	60	180	120	180	60	180	120	180	60	180	120	180	60	480	180	0	0	0	0	About 46
Rinse	60	8	60	180	120	42	60	180	120	180	60	240	120	180	60	180	120	180	60	180	120	180	60	180	120	180	60	480	180	0	0	0	0	About 28
Spin	60	8	60	180	120	42	60	180	120	180	60	240	120	180	60	180	120	180	60	180	120	180	60	180	120	180	60	480	180	0	0	0	0	About 17

* Basic Cycle
 * Optional Cycle
 * Pre-Setting Time : Water Supply - 120 sec.
 Drain - 60 sec.

* Wash time is in minutes.
 ** The total working time will vary with the load size, water temperature and ambient temperature.

7. TROUBLE SHOOTING

7-1.BEFORE SVC CHECKING

- Be careful of electric shock or disconnecting the parts while trouble shooting.
- Voltage of each terminal in 220-240V~ and DC while applying an electric current.

7-2.QC TEST MODE.

- ① Pressing Rinse, and Spin button simultaneously.
- ② Press the Power  button, while the above condition.
- ③ Press the Start/Pause button as follows.

Number of times the Start/Pause button is pressed	Check Point	Display Status
None	Turns on all lamps and locks the door.	
1 time	Tumble clockwise.	rpm (40~50)
2 times	Low speed Spin.	rpm (600~650)
3 times	High speed Spin.	rpm (1300~1350)
4 times	Inlet valve for prewash turns on.	Water level frequency (25~65)
5 times	Inlet valve for main wash turns on.	Water level frequency (25~65)
6 times	Inlet valve for hot water turns on.	Water level frequency (25~65)
7 times	Tumble counterclockwise.	rpm (40~50)
8 times	Heater turns on for 3 sec.	Water temperature
9 times	Circulation pump turns on.	Water level frequency (25~65)
10 times	Drain pump turns on.	Water level frequency (25~65)
11 times	Power off and unlock the door.	Turn off all lamps.

7-3.HOW TO KNOW THE WATER LEVEL FREQUENCY

* Press the Rinse and Spin button simultaneously.

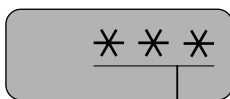

● The digits means water level frequency(10^{-1} kHz)









ex) 241 : Water level frequency = 241×10^{-1} kHz
=24.1 kHz



7-4.HOW TO KNOW TO TEMPERATURE OF EACH THERMISTOR AT OPERATING CONDITION.

■ Thermistor in tub : Press the [Temp.] button.

7-5.ERROR DISPLAY.



- If you press the Start/Pause button in error condition, any error except 'PE' will disappear and the machine will change into pause status.
- In case of 『PE』, 『LE』, 『HE』, if the error is not resolved within 20 sec., and in case of other errors, if the error is not resolved within 4 min., power will be turned off automatically and the error only will be blinked. But in case of 『FE』, power will not be turned off.



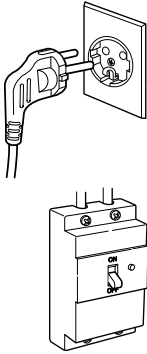

	ERROR	SYMPTOM	CAUSE
1	WATER INLET ERROR		<ul style="list-style-type: none"> • Not reached to the water level(246)within 8 minutes after water supplied or not reached to the preset water level within 25 minutes.
2	DRAIN ERROR		<ul style="list-style-type: none"> • Not fully drained within 10 minutes.
3	OVERFLOW ERROR		<ul style="list-style-type: none"> • Water is over flowing(over 8 level). ※ If  is displayed, drain pump operates to drain water automatically.
4	SENSOR PRESSURE S/W ERROR		<ul style="list-style-type: none"> • The sensor pressure switch is out of order.
5	DOOR OPEN ERROR		<ul style="list-style-type: none"> • In case of operating the reservation function or the other function with door opened. Close the door, then the error display is resolved. • The door switch is out of order.
6	IMBALANCE ERROR		<ul style="list-style-type: none"> • The appliance is tilted. • Laundry is gathered to one side.
7	HEATING ERROR		<ul style="list-style-type: none"> • The THERMISTOR is out of order.

	ERROR	SYMPTOM	CAUSE
8	CURRENT ERROR		<ul style="list-style-type: none"> • MAIN PWB ASSEMBLY is out of order <ul style="list-style-type: none"> ☞ Replace the MAIN PWB ASSEMBLY • Winding in the STATOR ASSEMBLY is short-circuited. <ul style="list-style-type: none"> ☞ Replace the STATOR ASSEMBLY • “CE ” is displayed during a high spin <ul style="list-style-type: none"> ☞ Replace the LEAD WIRE ASSEMBLY (MOTOR)
9	MOTOR ERROR		<ul style="list-style-type: none"> • The connector in the LEAD WIRE ASSEMBLY is not connected to the connector of STATOR ASSEMBLY <ul style="list-style-type: none"> ☞ Reconnect or repair the connector • The hall sensor is out of order/defective. <ul style="list-style-type: none"> ☞ Replace the STATOR ASSEMBLY
10	DRY HEATOR ERROR		<ul style="list-style-type: none"> • Water leaks [WD-14310(5)FD/WD-12310(5)FD]

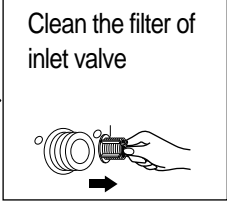
8. ERROR DIAGNOSIS AND CHECK LIST

8-1. DIAGNOSIS AND ANSWER FOR ABNORMAL OPERATION

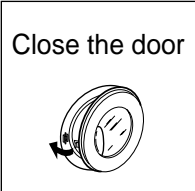
SYMPTOM	GUIDE FOR SERVICE CALL	
<p>NO POWER</p>	<p>Is the power plug connected firmly to 220-240V~ outlet?</p> <p style="text-align: center;">YES</p> <p>Power failure? or Breaker opened?</p> <p style="text-align: center;">NO</p> <p style="text-align: center;">Visit to check</p>	
<p>Water inlet trouble</p> 	<p>Is " IE " displayed?</p> <p style="text-align: center;">YES</p> <p>Is the tap opened?</p> <p style="text-align: center;">YES</p> <p>Is the tap frozen?</p> <p style="text-align: center;">NO</p> <p>Is the water supply shut-off?</p> <p style="text-align: center;">NO</p> <p>Is filter in the inlet valve clogged with foreign material?</p> <p style="text-align: center;">NO</p> <p style="text-align: center;">Visit to check</p>	 <p style="text-align: center;">YES</p> <p>Clean the filter of inlet valve</p> 

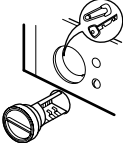
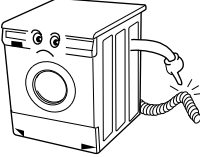
SYMPTOM	GUIDE FOR SERVICE CALL
<ul style="list-style-type: none"> • Door does not open • Error displayed on the program 	<p>Started with door opened? YES </p> <p>NO</p> <p>Close the door </p> <p>Visit to check</p> <p><Check if the door switch is O.K.></p>
<ul style="list-style-type: none"> • DRAIN TROUBLE 	<p>Is "E2" displayed?</p> <p>YES</p> <p>Is the debris filter clogged with foreign material such as pin, coin and etc.? YES Clean up the filter. </p> <p>NO</p> <p>Is the drain hose frozen with water, kinked or crushed?</p> <p>NO</p> <p>Visit to check </p>

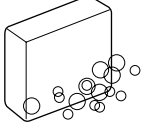
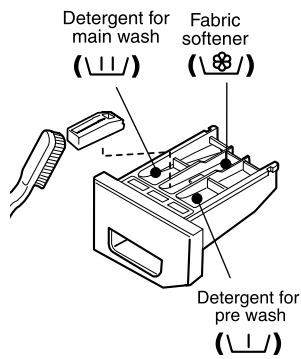
SYMPTOM	GUIDE FOR SERVICE CALL
<p>◦ Suds overflow from the appliance. (In this condition, wash and spin do not operate normally)</p>	<div style="display: flex; justify-content: space-between;"> <div style="width: 60%;"> <p>Is low-sudsing detergent for the drum washing machine used?</p> <p style="text-align: center;">YES</p> <p>Is the proper amount of detergent used as recommended?</p> <p style="text-align: center;">YES</p> <p>Recommend to reduce the using amount of detergent.</p> <p>* This appliance has the automatic suds sensing function which operates under much suds condition for good rinse and preventing overflow. * When much suds are sensed, suds removing function such as drain, water input and pause will operate without rotating the drum.</p> </div> <div style="width: 35%; text-align: center;">  <p>LOW-SUDSING</p> </div> </div>
<p>◦ No effect of softener</p>	<div style="display: flex; justify-content: space-between;"> <div style="width: 60%;"> <p>Is softener put in the correct compartment of the drawer?</p> <p style="text-align: center;">YES</p> <p>Is the drawer closed during wash?</p> <p style="text-align: center;">YES</p> <p>Is the softener cap clogged?</p> <p style="text-align: center;">YES</p> <p>Explain how to use softener</p> <p>< Clean the compartment for softener ></p> </div> <div style="width: 35%; text-align: center;">  </div> </div>
<div style="display: flex; flex-direction: column; align-items: center;"> <div style="display: flex; gap: 10px; margin-bottom: 5px;"> <div style="border: 1px solid black; padding: 2px 5px;">FE</div> <div style="border: 1px solid black; padding: 2px 5px;">AE</div> </div> <div style="display: flex; gap: 10px; margin-bottom: 5px;"> <div style="border: 1px solid black; padding: 2px 5px;">FE</div> <div style="border: 1px solid black; padding: 2px 5px;">CE</div> </div> <div style="display: flex; gap: 10px;"> <div style="border: 1px solid black; padding: 2px 5px;">EE</div> <div style="border: 1px solid black; padding: 2px 5px;">LE</div> </div> </div>	<p style="text-align: center; border: 1px solid black; border-radius: 15px; padding: 5px;">Visit to check</p>

8-2.FAULT DIAGNOSIS AND TROUBLE SHOOTING

CAUTION

1. Be careful of electric shock or disconnecting the parts while trouble shooting.
2. First of all, check the connection of each part terminal with wiring diagram.
3. If you replace the MAIN PWB ASSEMBLY, Put in the connectors correctly.

NO POWER

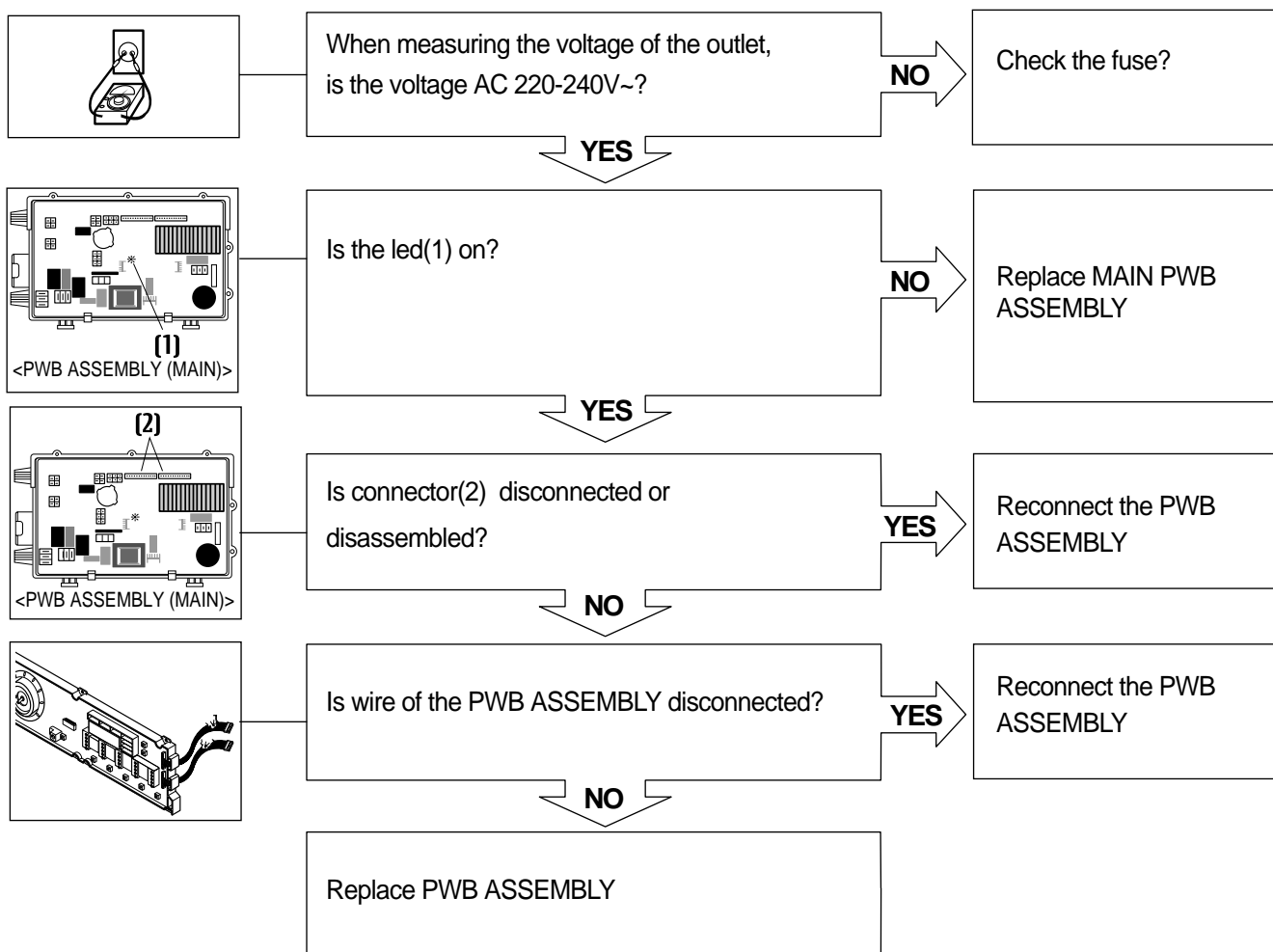

NO WATER SUPPLY

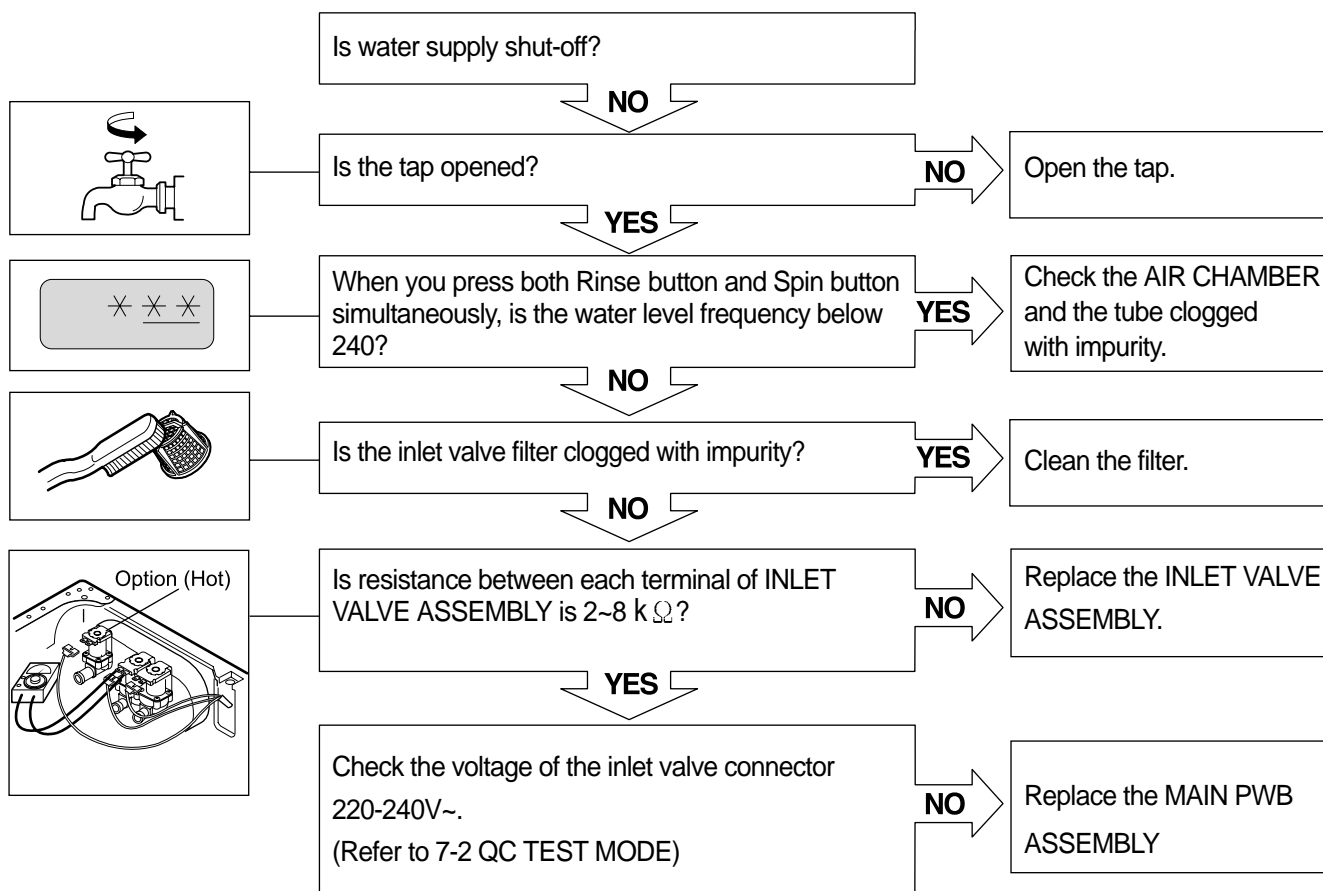

DETERGENT DOES NOT FLOW IN

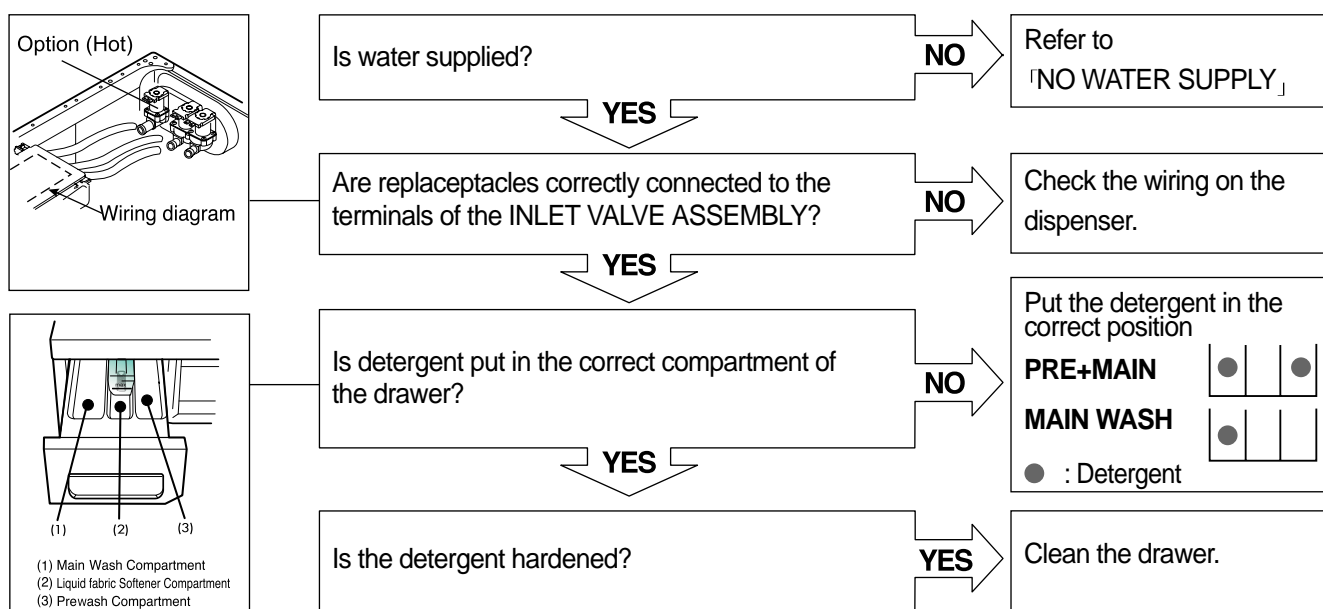

SOFTENER DOES NOT FLOW IN

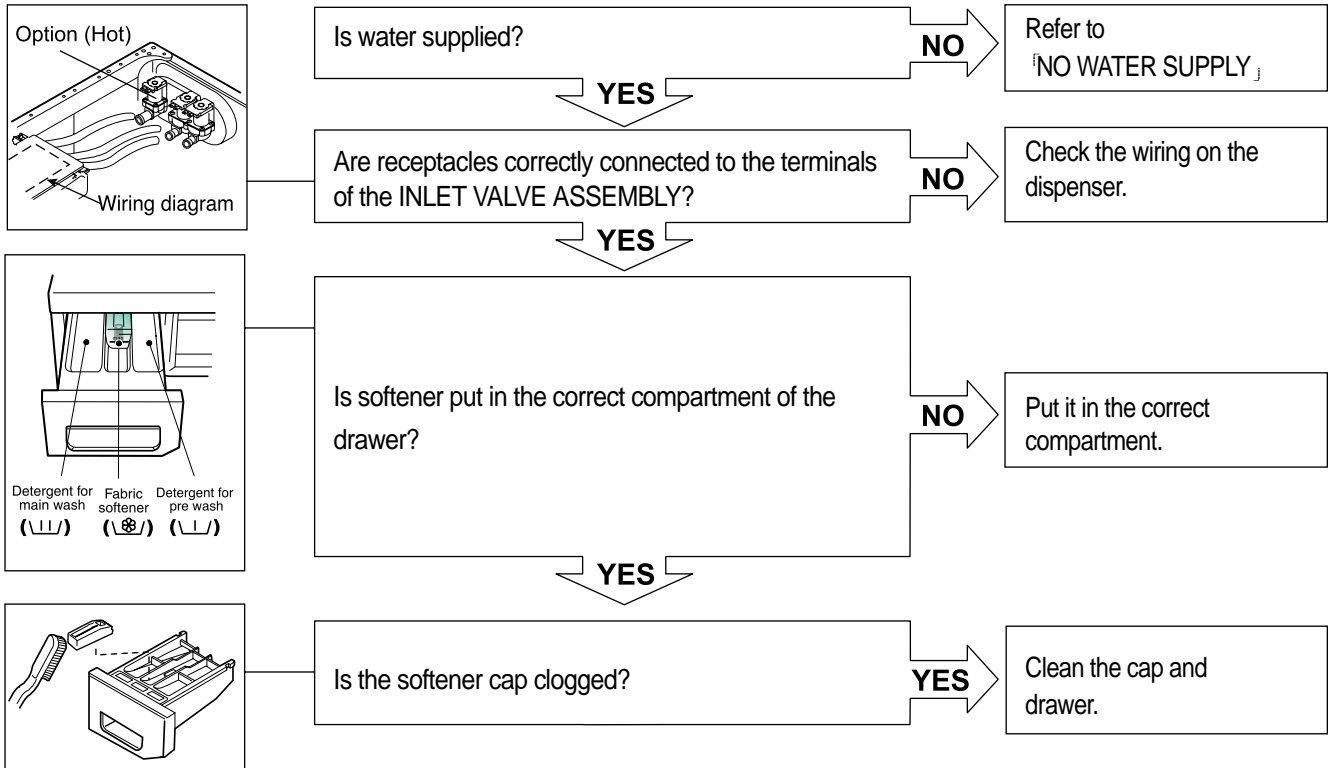

ABNORMAL SOUND

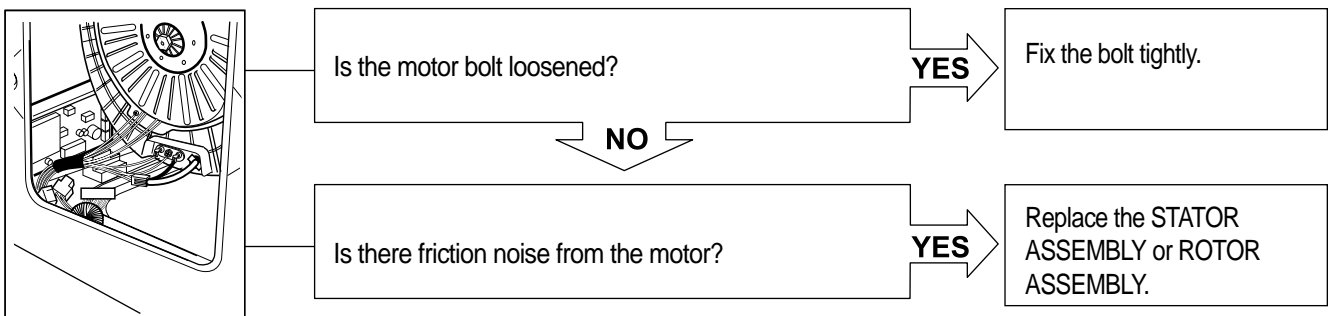

HEATING WITHOUT WATER

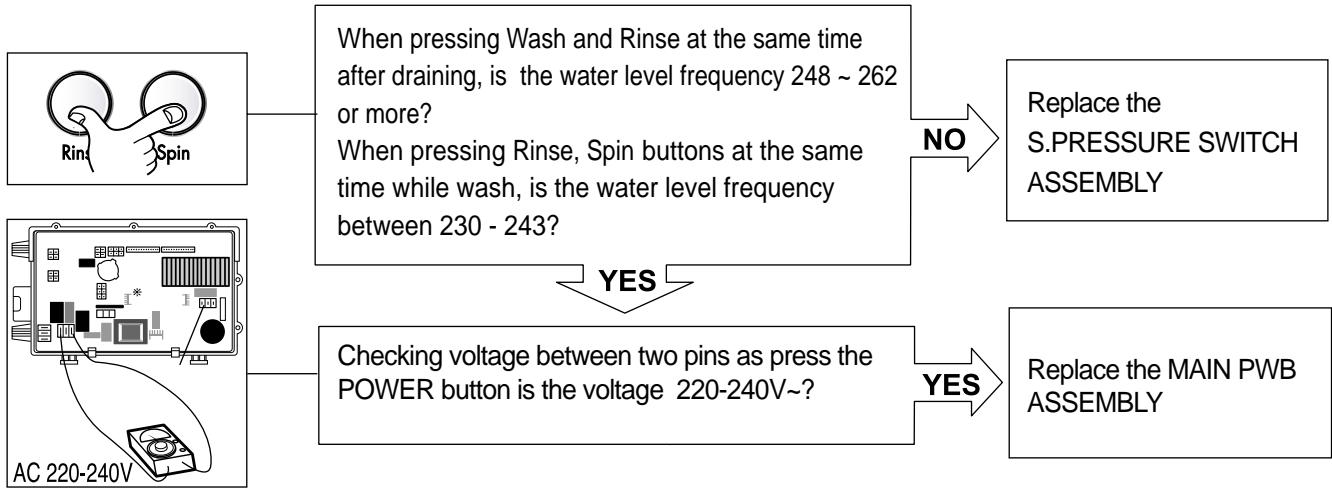

DRAIN MALFUNCTIONING

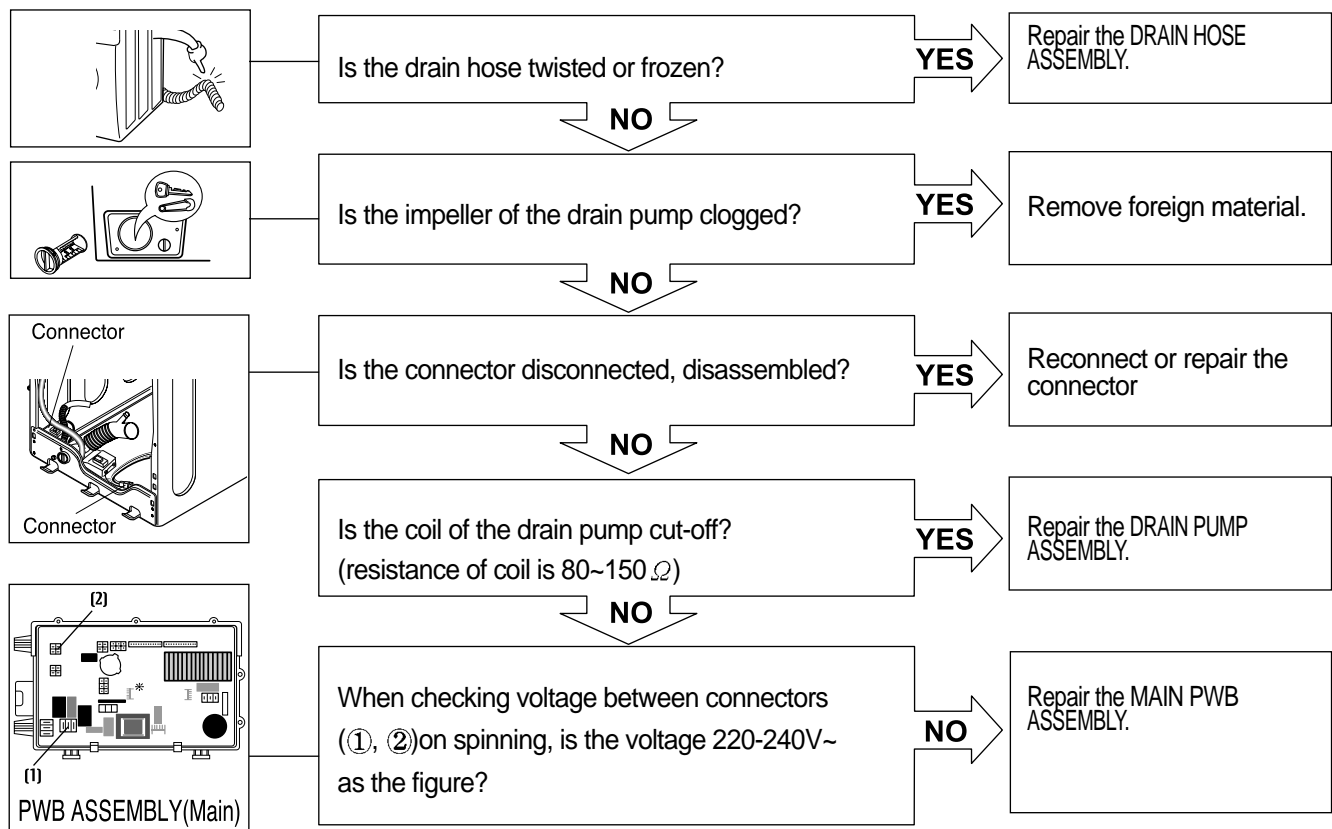

WASH HEATER TROUBLE

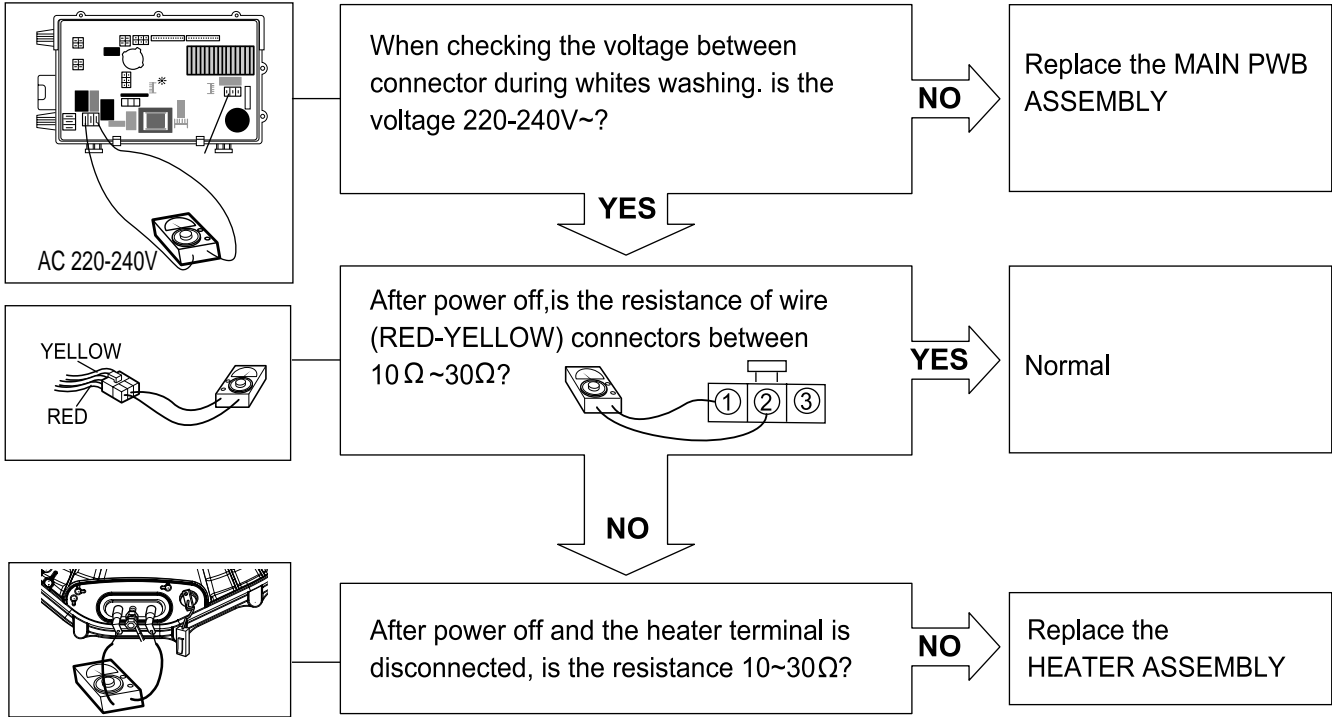

HEATING CONTINUOUSLY ABOVE THE SETTING WATER TEMPERATURE

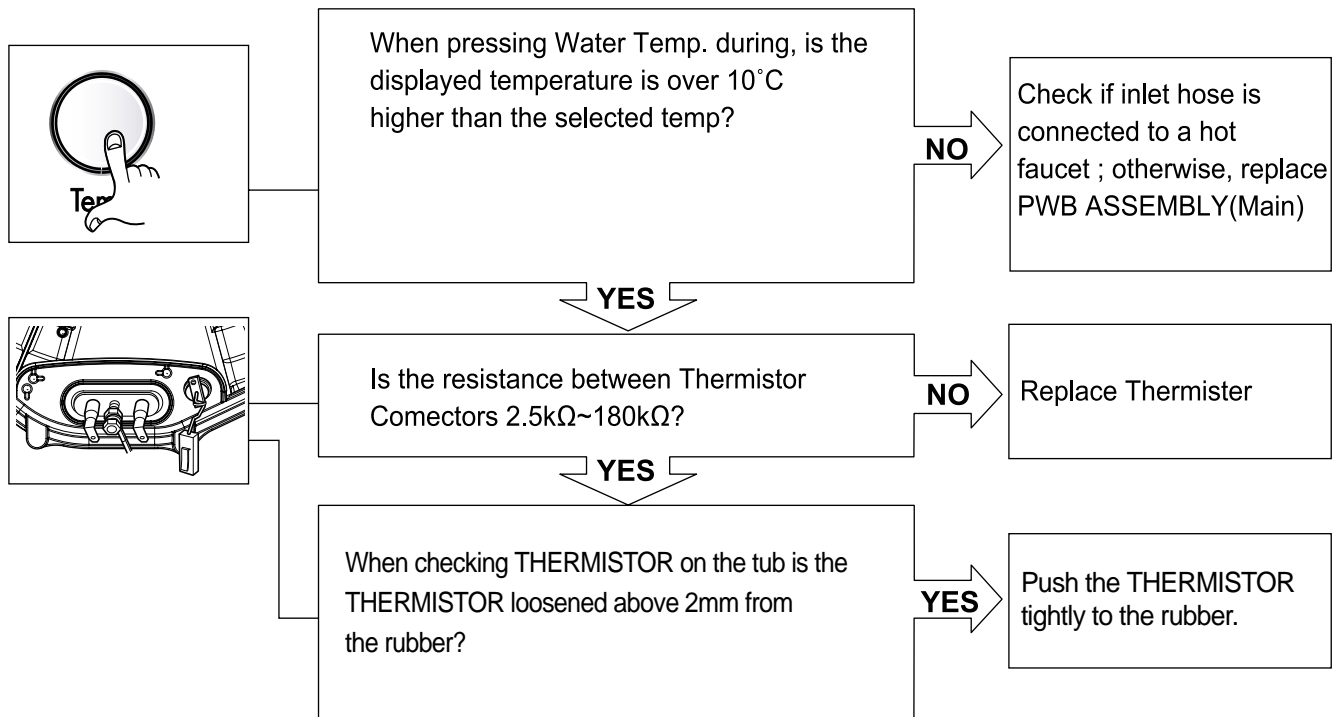

SPIN TROUBLE

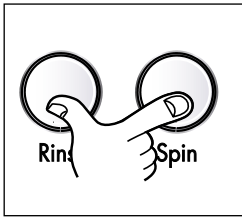

Check on the spinning, is the frequency of the water level 248 or more. The frequency can be checked by pressing the Wash and Rinse buttons at the same time on the program.

NO

Check the S.PRESSURE SWITCH ASSEMBLY or HOSE (Pressure). If the problem is on the S.PRESSURE SWITCH ASSEMBLY or the HOSE, replace the S.PRESSURE SWITCH ASSEMBLY or the HOSE.

YES

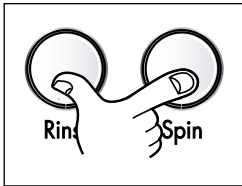

When pressing Rinse, Spin and POWER buttons at the same time after power off, press the Start/Pause button 1 times, is the drum low speed spin?

YES

Normal

NO

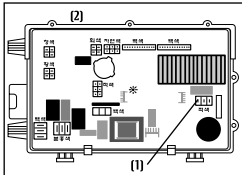

Is it disconnected, or disassembled?
[Red:3pin(1), GY:4pin(2)]

YES

Correct the connector.

NO

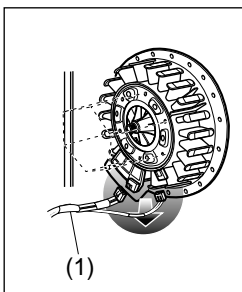

Check the motor connector, is the resistance of the terminal same as the figure?

MOTOR TERMINAL (1)

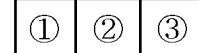

Resistance of terminal:

①~② / ②~③ / ③~① : About 5 Ω~15 Ω

NO

Replace the STATOR ASSEMBLY

YES

Replace the MAIN PWB ASSEMBLY

E ERROR

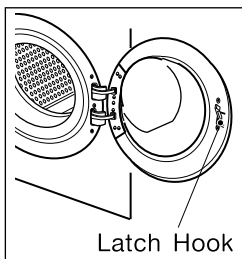

Does the spring of Latch Hook actuate?

NO

Replace Door Assembly.

YES

Is there clicking sound once or twice when the **START/PAUSE** button is pressed to start the cycle?

NO

Check the DOOR SWITCH ASSEMBLY Connector and MAIN PWB ASSEMBLY (Red 3 pin, Yellow 4 pin and white 3 pin connector (1)).

YES

Is DOOR SWITCH ASSEMBLY broken?

YES

Replace the DOOR SWITCH ASSEMBLY.

9. DISASSEMBLY INSTRUCTIONS

* Disassemble and repair the parts after pulling out power cord from the outlet.

CONTROL PANEL

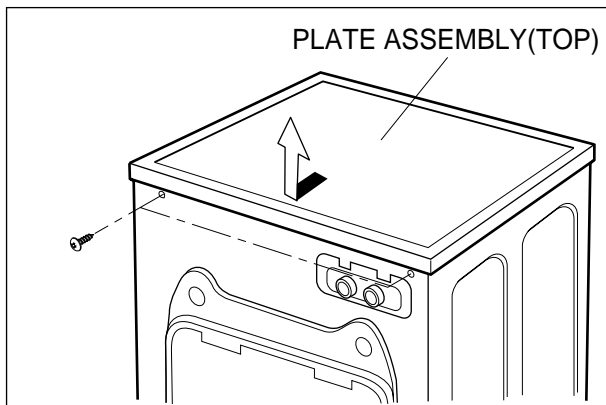

- ① Unscrew the screws on the top plate.
- ② The plate assembly(Top) is pulled back and then upward to arrow direction.
- ③ The cover(Inner) is disassembled.

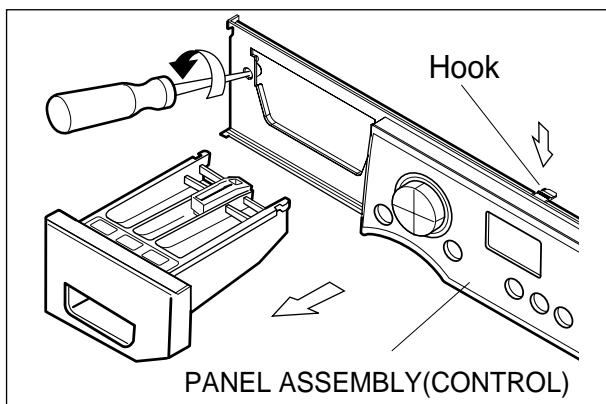

- ① The PWB assembly(Display) connectors are disconnected.
- ② Pull out drawer, three screws are unscrewed.
- ③ Push two upper hooks and pull the control panel forward.

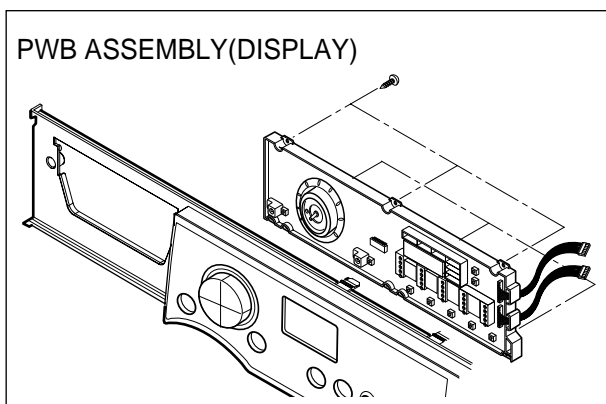

- ① The PWB assembly(Display) is disconnected.
- ② When 6 screws are unscrewed on the PWB insulator and the PWB assembly(Display) is disassembled from the PWB insulator.

PWB ASSEMBLY(MAIN)

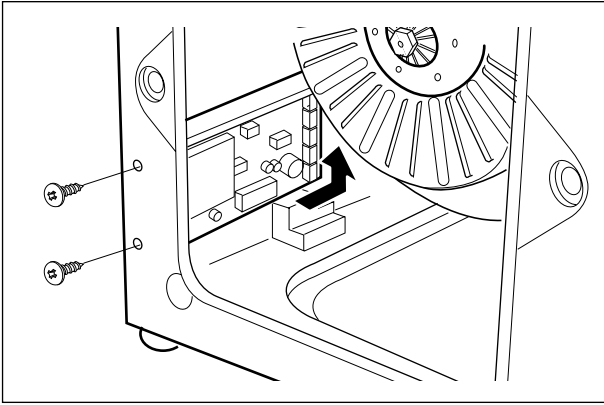

- ① The back cover is removed.
- ② Two screws are unscrewed.
- ③ Disconnect connector from the wiring.
- ④ Pull the PWB assembly (Main) to arrow direction.

DISPENSER ASSEMBLY

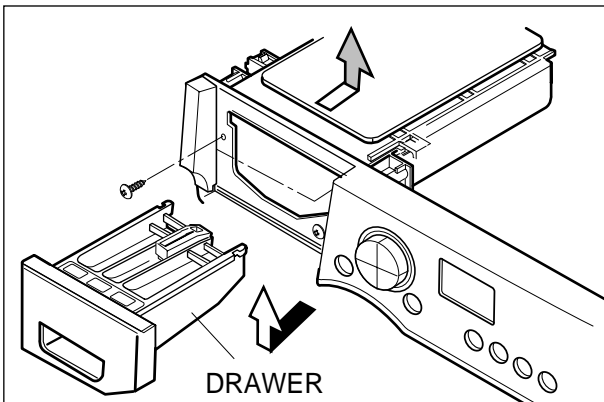

- ① The plate assembly(Top)and the cover(Inner)are disassembled.
- ② Pull the drawer to arrow direction.
- ③ Two screws are unscrewed.

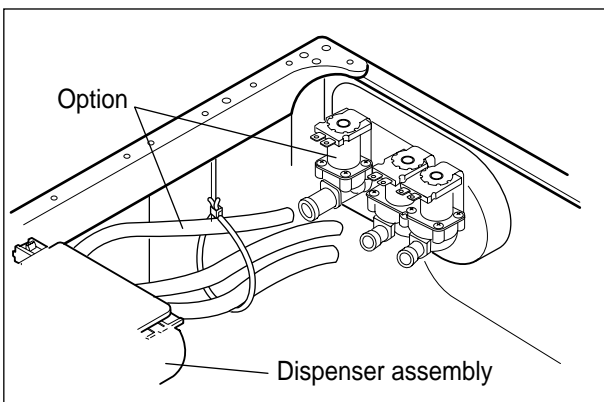

- ① The hose clamps and the hose are disassembled.
- ② The ventilation bellows are disassembled on the tub.

INLET VALVE

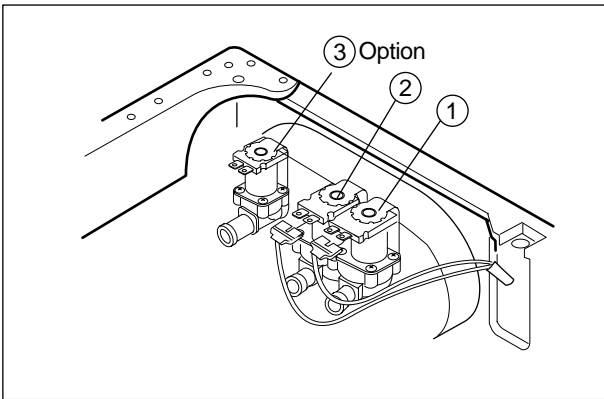

- ① Disconnect the wiring connector.
- ② Remove the valve by two screws of the valve holder.

* When reconnecting the connector

VALVE ① (PRE-WASH)	GY/WH - BK
VALVE ② (NORMAL-WASH)	WH/BK - BK BL/RD - BK
VALVE ③ (HOT)	BL/RD - BK

DOOR

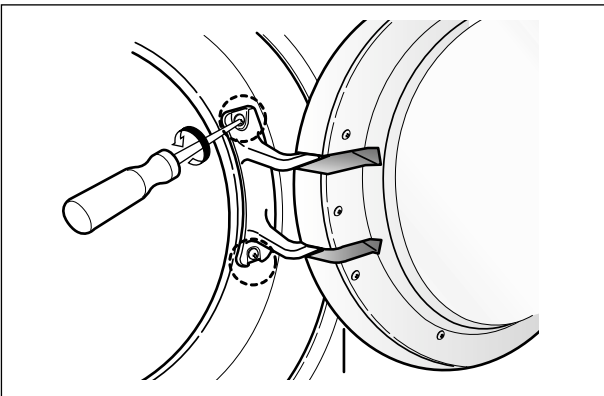

- ① Open the door completely.
- ② Remove the two screws from the hinge.

* When removing the Door Assembly, it is necessary to hold the Bracket that is inner of the Cabinet Cover.

Removing method of remained water

Pull it out from hose.

* First, prepare a bucket to put in the remained water.

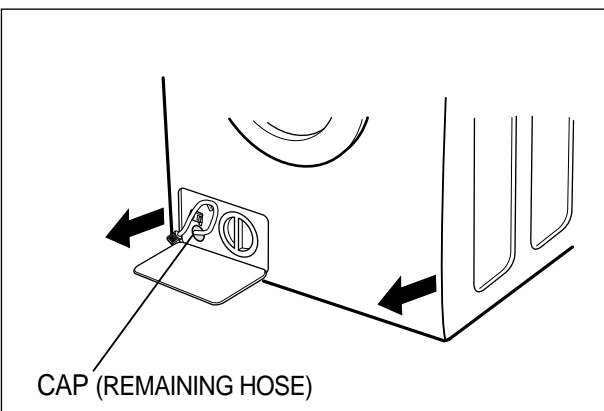

GASKET ASSEMBLY

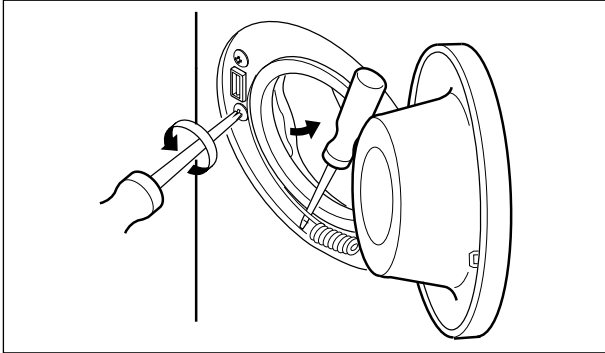

- ① The cabinet gasket clamp is released.
- ② Two screws are unscrewed from the cabinet cover.

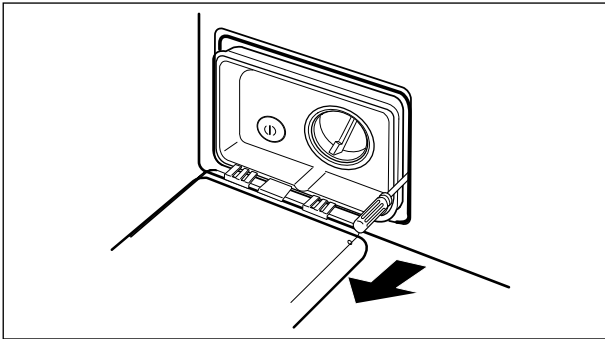

- ① Pull flat(-) screwdriver or pully knife into the both sides of filter cover, and pull in out.

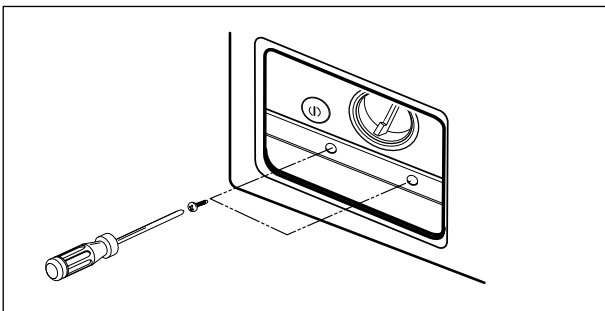

- ① Unscrew the screw from the lower side of the cabinet cover.

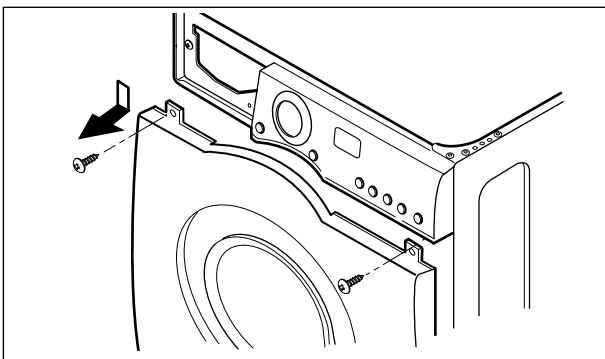

- ① Unscrew the 2 screw from upper of the cabinet cover.

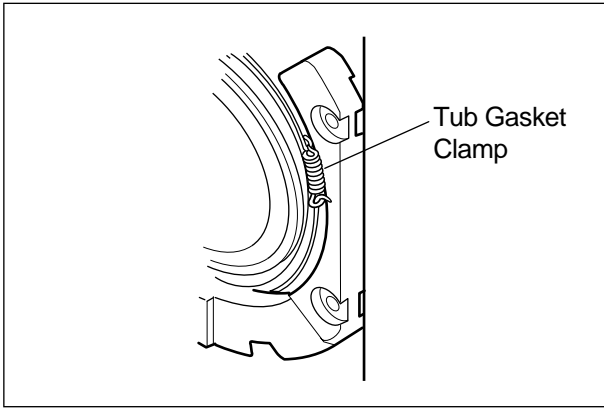
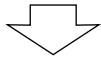

① Disassemble the clamp assembly.

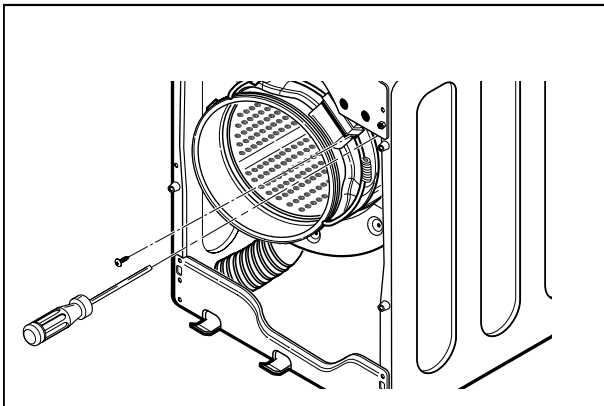
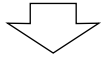

① Remove dry gasket clamp by loosening the screw.

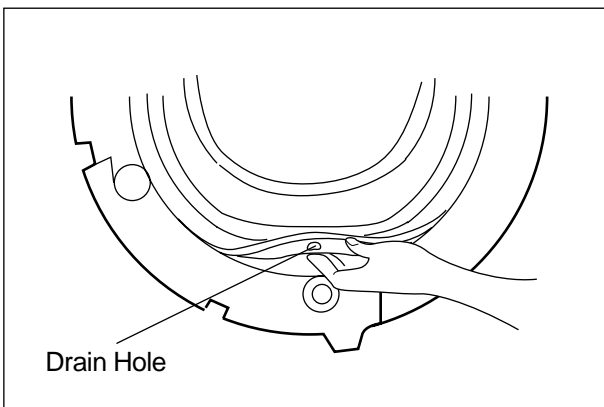
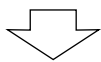

① When reassembling the gasket, put the drain hole of the gasket downward, then assemble.

ROTOR ASSEMBLY, STATOR ASSEMBLY, FRICTION DAMPER

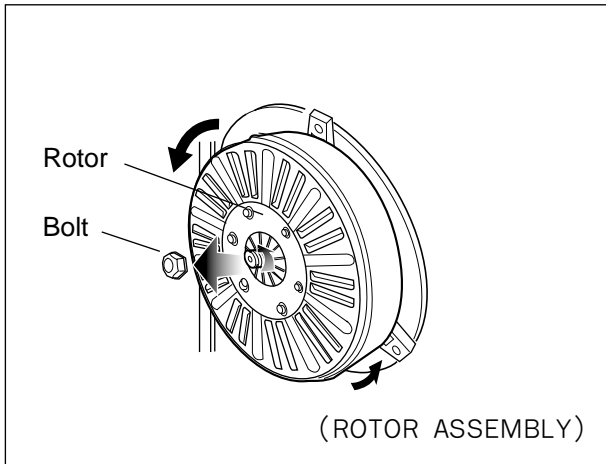

- ① Remove the back cover.
- ② After loosening the bolt, Rotor, pull out the rotor.

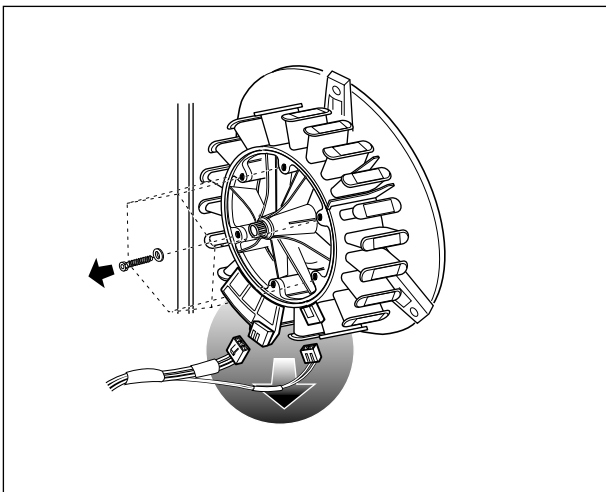

- ① Remove the 6 bolt from the stator.
- ② Disconnect the 2 connectors.

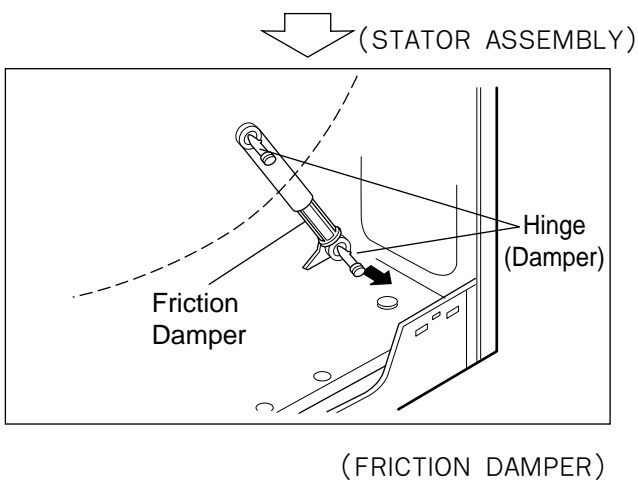

- ① Remove the hinges (Damper) at the Tub.
- ② The Hinge(Damper) at the base is pulled off pressing on the snaps at the sharp end.
- ③ The hinge at the base is pulled off. (To arrow direction)

PUMP

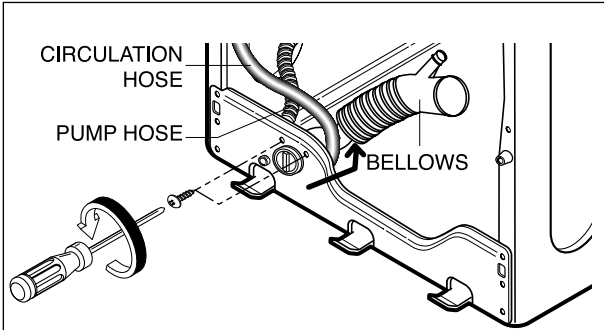

- ① Remove pump outlet hose.
- ② Remove tub pump bellows.
- ③ Remove cap(Remaining Hose).
- ④ Disconnect the wiring.
- ⑤ Three screws are unscrewed from the cabinet.
- ⑥ Remove the pump to arrow direction.

HEATER

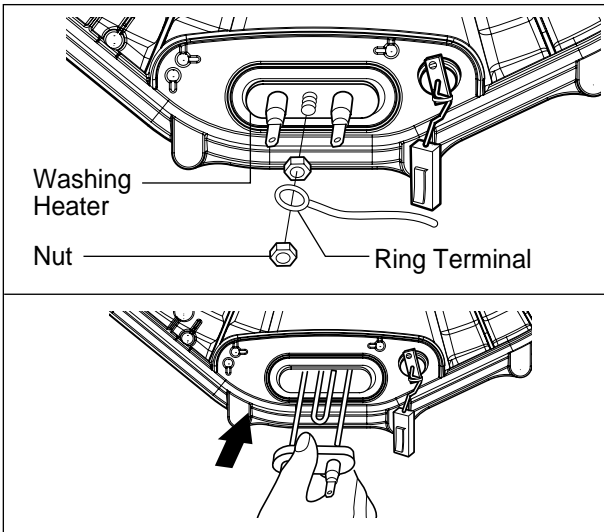

- ① Loosen the nut.
- ② Remove washing heater by pulling out.

CAUTION

When assembling the washing heater, insert the heater to heater clip on the bottom of tub.

THERMISTOR

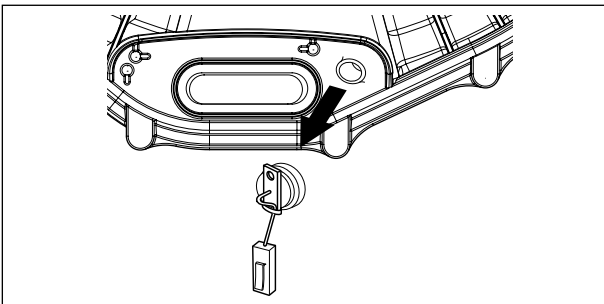

- ① Pull it out by holding the thermistor bracket.
* If holding the wire and pulling out it, it may be broken.

SWITCH ASSY, DOOR LOCK

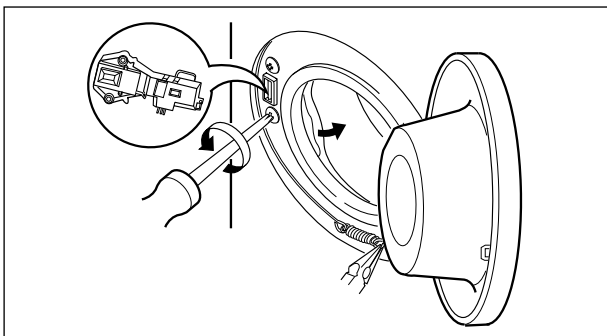

- ① The cabinet cover clamp is removed and the gasket is released.
- ② Two screws are unscrewed.
- ③ The door lock S/W is disconnected from the wiring connector and the strap.

WHEN FOREIGN OBJECT STUCK BETWEEN DRUM AND TUB

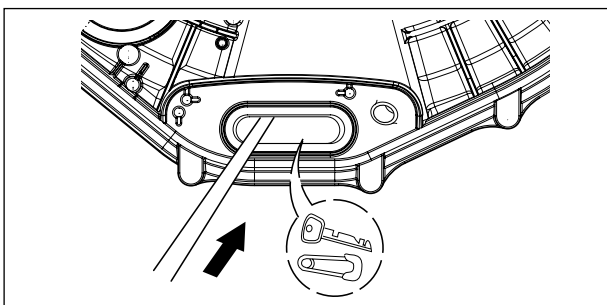

- ① Remove washing heater.
- ② Remove the foreign object(wire, coin, etc) by inserting long bar in the hole.

SWITCH ASSEMBLY, SAFETY

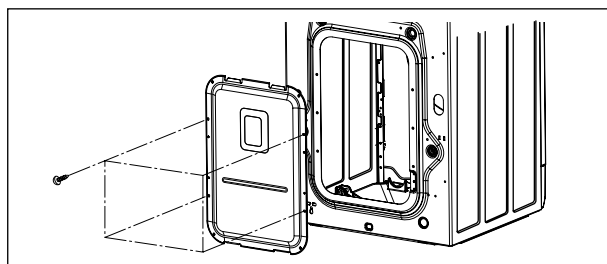

- ① Unscrew 4 screws from the back cover.

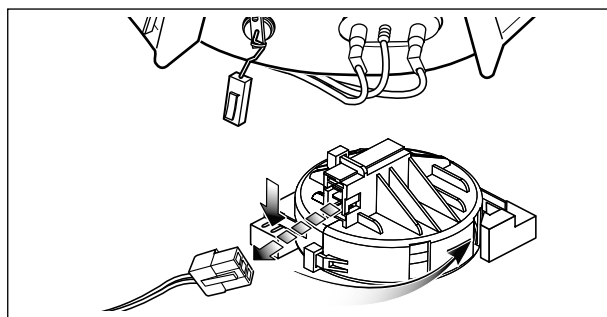

- ② Disconnect the wiring connector.
- ③ Turn and press hook of switch assembly safety.

10. EXPLODED VIEW AND PART LIST

10-1. THE PART LIST OF CABINET ASSEMBLY

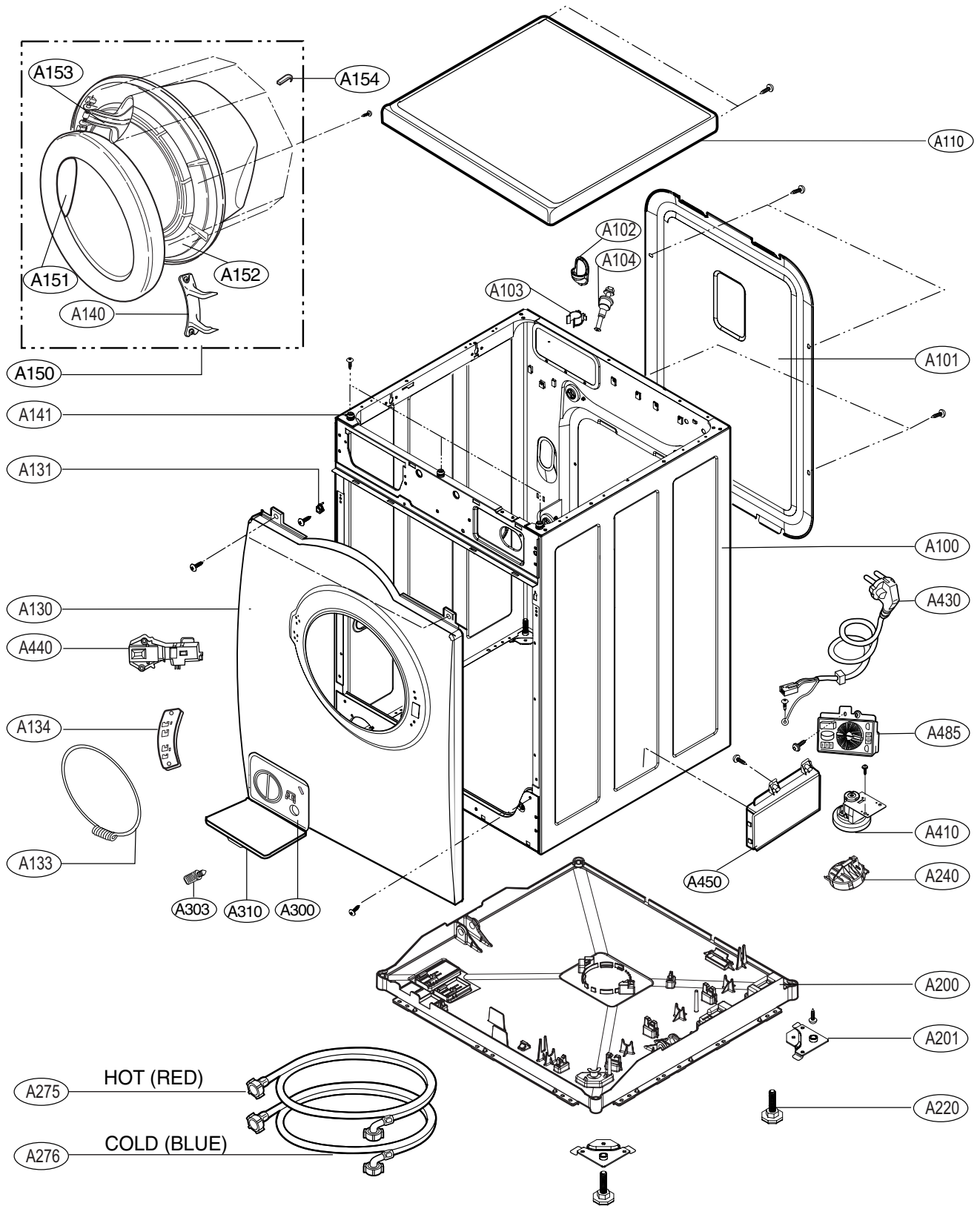

10-2 THE EXPLODED VIEW OF CONTROL PANEL & DISPENSER ASSEMBLY

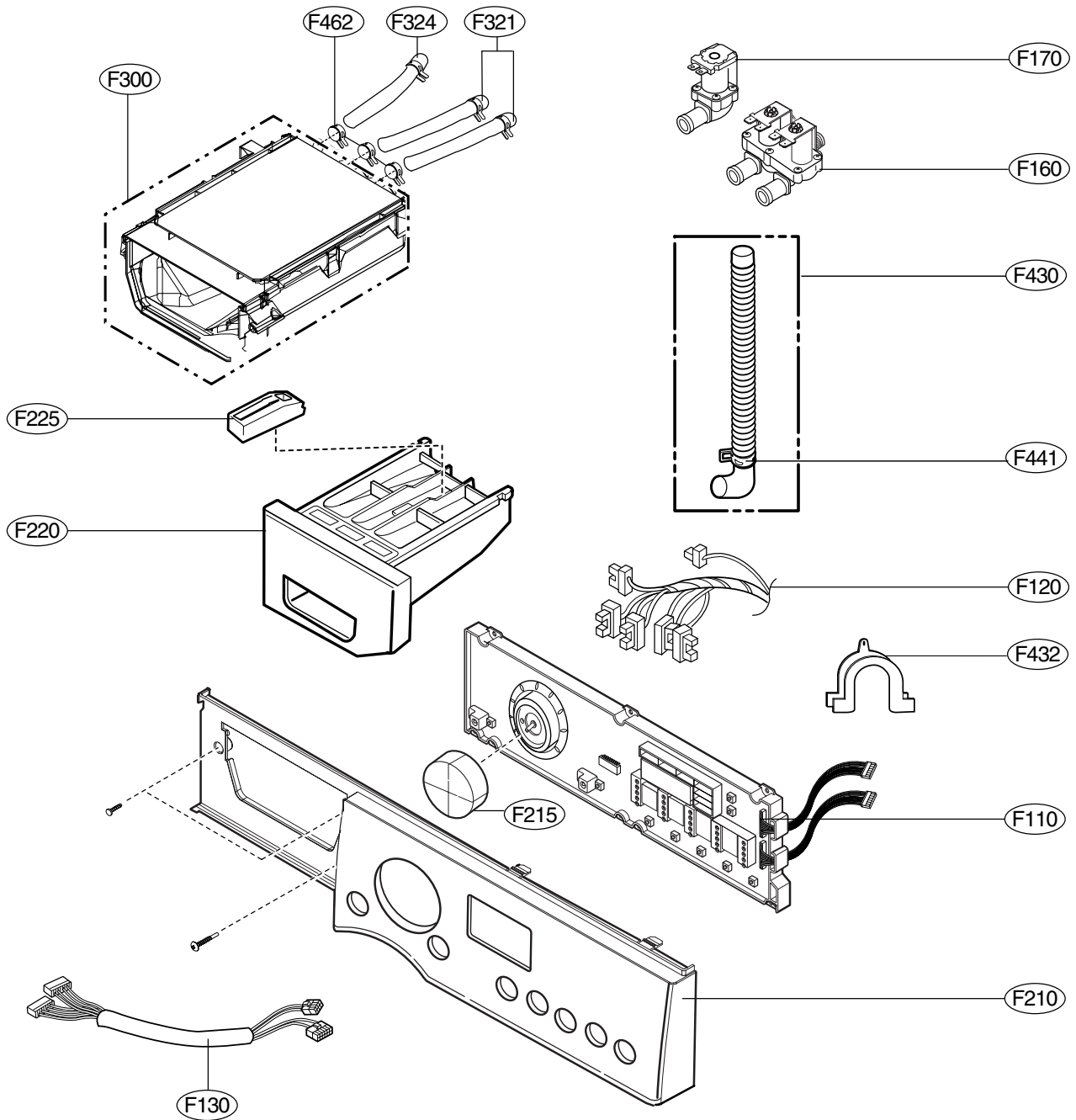

10-3 THE EXPLODED VIEW OF DRUM & TUB ASSEMBLY

